



# YORK SunPremier 25 Ton to 80 Ton Rooftop Units Technical Guide



---

Technical Guide

Issue Date: 2024-02-02

Form Number: 5514889-YTG-D-0224

Supersedes: 5514889-YTG-C-1123

---



# Contents

Product highlights and options.....	5
Component location.....	7
Features and benefits.....	8
Nomenclature - 25 ton to 80 ton model number.....	12
Selection procedure examples.....	15
Physical data.....	18
Capacity performance.....	23
Airflow performance.....	94
Electrical data.....	110
Controls.....	119
Weights and dimensions.....	132
Guide specifications.....	192



# Product highlights and options

## Efficiency

- 2023 DOE efficiency as standard
- Optional integral energy recovery wheel (ERW)
- Optional variable speed drive compressors
- Standard direct drive plenum (DDP) supply fan

## Flexibility

- 208 VAC to 230 VAC, 460 VAC, or 575 VAC, 3 phase, 60 Hz
- Cooling only units with heating options including gas, electric, steam or hot water with modulation
- Exhaust or return fan options
- Various airflow path configurations for discharge and return and exhaust air
- Optional humidifier, sound attenuator, or air blender
- Optional low ambient temperature
- Variable frequency drive (VFD) options on all fans, see [Figure 1](#)

**Figure 1: VFD displays**



LD30028

## Reliability and serviceability

- Multiple refrigeration circuits
- Coil corrosion protection option
- Unit powered convenience outlet
- Optional door viewports
- Single point latching door option
- Internal air handler light option
- Replaceable core filter drier option
- Suction, liquid, and discharge line shutoff valve options
- Refrigeration pressure transducer options
- Start-up wizard

## Indoor environmental quality

- Double wall construction with foam insulation
- Modulating hot gas reheat (HGRH) option
- Final filtration options, including high efficiency particulate air (HEPA) filters
- Ultraviolet (UV) lights option, see [Figure 2](#)
- Stainless steel drain pan
- Condensate overflow switch option
- Airflow measurement options for outside air, supply fan, and return fan

## Controls

- 5.5 in., 5 row × 35 character (256 × 64 dot matrix) organic light-emitting diode (OLED) display with full numeric keypad and navigation buttons as standard
- 10 in., 1280 × 800 resolution, multi-touch capacitive, color touchscreen display available as a factory installed or field installed option
- Optional WiFi hotspot capability via a mobile access portal (MAP) device provides additional unit control when it is not always possible to physically access the unit
- Smart Equipment technology enabling self-discovery on Verasys™ Building Automation Systems (BAS)
- The controller supports the BACnet® communication protocol and is designed and certified by BACnet Testing Laboratory (BTL) to meet the requirements of the advanced application control profile

- Twinning algorithms to allow multiple units to function as one on common supply and return duct shafts
- Variable air volume (VAV) and single zone VAV (SZVAV) control
- Building pressurization controls

**Figure 2: UV lights**

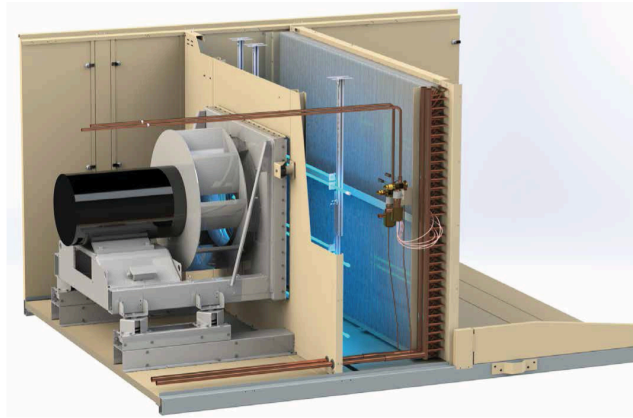

LD27640

## Patents

For access to Premier™ related patents, visit: <https://jciapat.com>.

# Component location

Figure 3: 25 ton to 80 ton packaged rooftop unit cabinet assembly

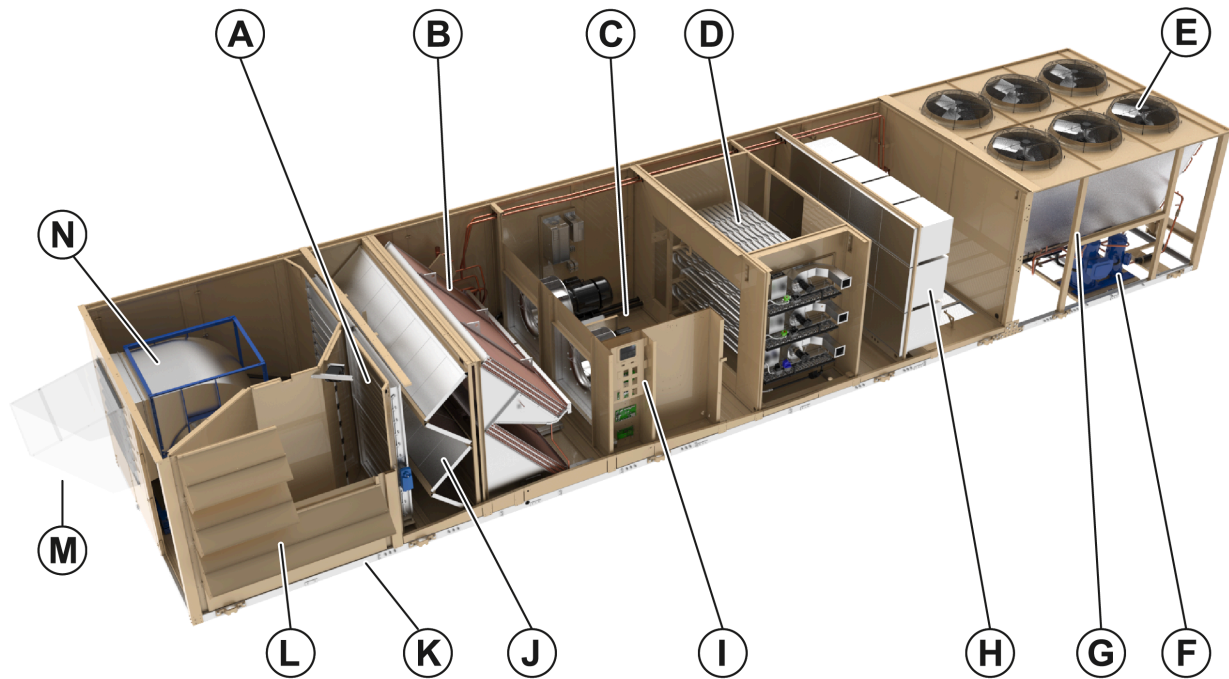

LD30001

**Note:** Some components listed are optional.

A	Economizer	H	Final filter
B	Evaporator coil	I	Unit controller and power
C	Direct drive plenum (DDP) supply fan	J	Filter section
D	Modulating or staged gas heat	K	Outside air (right side)
E	Condenser fans	L	Collapsible rain hoods
F	Scroll compressors	M	Exhaust air (front)
G	Condenser coil cleaning hatch (not shown)	N	Exhaust and return fan

# Features and benefits

## General

The 25 ton to 80 ton packaged rooftop platform is designed with all the flexibility needed for today's applications but with tomorrow's requirements in mind. Realizing that efficiency requirements are continuously pushing the envelope of technology, the YORK® Sun™ Premier delivers today the energy efficiency levels exceeding those mandated by the U.S. Department of Energy for 2023. All cooling only and electric heat units have an integrated energy efficiency ratio (IEER) in excess of 13.2. All units with gas or hydronic heat have an IEER in excess of 13. For these particular rooftop units, when equipped with a variable speed drive compressor, they deliver efficiency levels in excess of those suggested by the highest tier of the Consortium of Energy Efficiency (CEE) for 2019.

The Premier units are also designed for serviceability. These units feature options including a single handle latching mechanism for doors, a convenience outlet to power lights and tools, internal lights in the air handler section, viewports in doors of serviceable compartments to enable easier unit inspection, and extended grease lines to simplify fan bearing lubrication for belt driven fans. Standard direct drive supply fans, see item 3 in [Figure 3](#), do not require lubricating fan bearings or changing belts. Numerous refrigeration options are also available, including replaceable core filter driers, liquid and suction isolation valves, as well as high and low pressure transducers in each circuit that enable easier sub-cooling and superheat measurements.

Besides options, there are also standard features to ensure straightforward and safe servicing of the units, including coil cleaning hatches in the condenser section to make cleaning condenser coils effortless, and door safety latches to keep doors safe when opened in a pressurized compartment. A discrete high and low voltage compartment minimizes the amount of safety equipment required when only the low voltage compartment is accessed.

Selection Navigator is an online program available to assist in providing unit selections, performance reports, unit drawings, lifting lug and connection drawings, BAS controls points list, controls sequence of operation, guide specification, and outputs to assist in design of the unit. Certain options may require the assistance of the local sales office.

In order to facilitate its application, Selection Navigator also provides building information modeling (BIM) files of the specific unit selected.

This aids in modeling placement and integration of the rooftop unit into the overall building design.

This packaged rooftop product is a sophisticated, highly configurable rooftop unit. A controller is standard on each unit with specific sequences of operation correlated to the options selected. Selection Navigator provides the specific sequences of operation for the unit options selected, eliminating confusion of the unit's capability.

Although the many options make customizing unlikely, it is possible to have custom mechanical and sequences of operations designed into the unit from the factory for ultimate convenience and reliability.

### 1. Economizer - see callout A in [Figure 3](#)

In order to deliver maximum efficiency, rooftop units need an efficient economizer. The rooftop unit offers various options for economizer control and fault detection, as well as damper leakage rates and cycle life to meet different regulatory requirements.

The amount of fresh air can also be optionally measured to ensure and record appropriate fresh air to the conditioned space. An air blender option is also available to deliver optimal comfort to the conditioned space.

### 2. Refrigeration System - see callouts B, E, and F in [Figure 3](#)

The refrigeration system is built to reliably deliver cooling through a variety of loads. Two independent refrigeration circuits ensure that in the unlikely event of a compressor failure, the second circuit can still deliver cooling to the space. An interlaced tube and fin evaporator provide maximum cooling performance even at part loads. The microchannel condenser reduces the risk of refrigerant leaks and minimizes the amount of refrigerant in the unit.

Standard fixed speed scroll compressors of different sizes deliver excellent part-load efficiency and control, which eliminates the need for inefficient hot gas bypass valves at low load conditions. Optional variable speed drive scroll compressor configurations are available for stable and efficient discharge air temperature (DAT) control regardless of the load.

For application flexibility, optional corrosion protection is available for the evaporator and condenser, as well as intrusion protection options for the condenser.

Realizing that the refrigeration system is the heart of the rooftop, when optionally equipped with transducers, the unit controller can display sub-cooling or superheat. Additionally, low ambient operation is an available option with a variable speed condenser fan.

Maximized serviceability is also available with options such as replaceable core filter driers as well as discharge, liquid, and suction line isolation valves. The standard unit is equipped with accessible sight glasses to verify proper refrigerant flow as well as conveniently located condenser coil cleaning hatches to facilitate maintenance.

### 3. Direct drive plenum (DDP) supply fan - see callout C in Figure 3

A direct drive plenum (DDP) supply fan, see Figure 4, provides outstanding reliability and efficiency, such as eliminating the possibility of interrupting conditioned air supply due to a broken belt or polluting conditioned air with belt dust. Multiple DDP supply fans, see Figure 5, are used on 60 ton to 80 ton cabinets for an increased level of reliability. The supply fan can be optionally equipped with an airflow measurement station to precisely measure the amount of air delivered to the conditioned space.

The speed of the supply fan is controlled by a variable frequency drive (VFD). VFD redundancy is optionally available to ensure uptime in the unlikely event of a VFD failure. Redundancy is provided by a redundant drive where a single supply fan motor is present. For multiple supply fan units an optional VFD is provided with each motor.

### 4. Heating options - see callout D in Figure 3

Gas heat options are available either in staged or modulating control. The flexibility of heater sizes meets the specific application heating needs. Electric heat is also available with size and staging and modulating options, see Figure 6. Either hot water or steam heat options are also available. All modulating heat options can be controlled precisely to temper the supply air, which is especially important when fresh air is needed in cold climates.

### 5. Double wall construction

The air handler section of the rooftop unit provides foam injected double wall construction for maximum unit rigidity and cleanability of the interior surfaces for long term indoor air quality (IAQ). This construction of the walls, roof, and floor provides an insulating value that minimizes unit sweating and contributes to the overall unit efficiency.

Figure 4: DDP supply fan

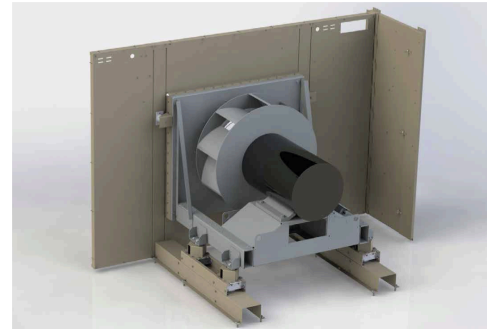

LD27636

Figure 5: Dual DDP supply fan

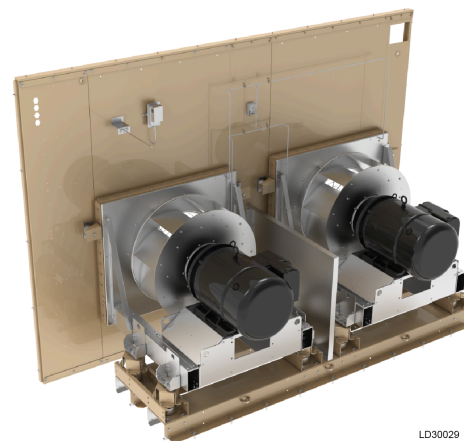

LD30029

Figure 6: Electric heat

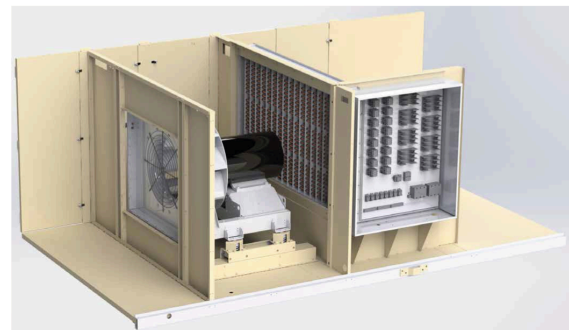

LD27637

### 6. Controls system - see callout I in Figure 3

The rooftop unit's sophisticated options are intelligently controlled by a best-in-class controls platform built exclusively for this application. A 5.5 in., 5 row x 35 character (256 x 64 dot matrix) organic light-emitting diode (OLED) display, see Figure 7, with full numerical and optimized navigational keypad or a 10 in., 1280 x 800 touchscreen LED display, see Figure 8, each conveniently located in the low voltage compartment, act as the nerve center. The control

system can be optionally augmented with a WiFi hotspot capability for local or line-of-sight smart device control. The touchscreen display shows a graphical representation of the Premier rooftop unit with real-time data, also enabling the ability to read documents and connect with multiple controllers.

**Figure 7: OLED display**



**Figure 8: Touchscreen display**



The control platform minimizes commissioning time when connected to the Verasys™ Building Automation Systems (BAS), with self-discovery of the rooftop unit and its points by the BAS.

The unit controller has sequences of operation for standalone applications. These sequences cover simple applications such as single zone variable air volume (SZVAV) control of the supply fan and compressors in accordance with ASHRAE 90.1-2019, as well as demand control ventilation (DCV) that ensures adequate fresh air to the building. Complex applications are also supported, like the twinning of multiple rooftops on a common supply and return duct shaft for the ultimate in redundancy for critical spaces, such as Medical Office Buildings (MOBs).

**Figure 9: Final filter section**

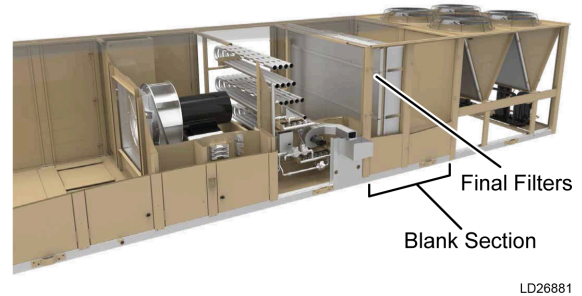

**7. Blank section - see Figure 9**

Blank sections can be provided for field installed accessories or to accommodate the installation of specific factory components including an air blender, final filters, humidifier, or sound attenuator.

The rooftop unit can be equipped with a final filter before the conditioned air is delivered from the rooftop into the supply duct. Various final filter options are available to meet critical needs including high efficiency particulate air (HEPA) filtration. Differential pressure measuring options can be supplied to meet the requirements for ASHRAE 170-2017.

For cold northern climates where heat tends to dry out the supply air, a humidifier option with a stainless steel drain pan is also available.

In order to mitigate sound originating in the rooftop unit from reaching the conditioned space, optional sound attenuators in the rooftop unit can be factory-installed.

**8. Exhaust and return fan - see callout N in Figure 3**

The rooftop units enable installation flexibility with the option of either exhaust or return fan to control the building static pressure. Return ductwork with shorter runs and lower static requirements usually only need an exhaust fan. A belt drive, 25 ton to 50 ton, or direct driven, 60 ton to 80 ton - Figure 10, plenum return fan is available to overcome the static imposed by longer return ducts.

**Figure 10: DDP return fan**

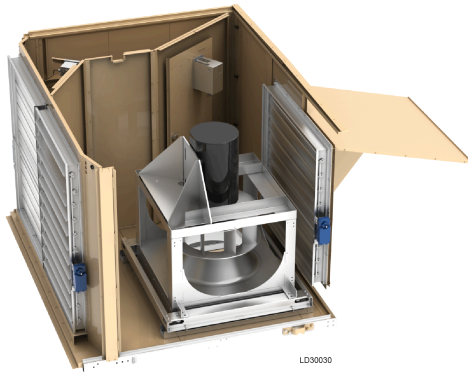

Optional airflow measurement is available for units equipped with a return fan. This makes it possible to precisely understand and log the different airflows through the rooftop unit.

### 9. Hot gas reheat (HGRH)

Occupant comfort can be a challenge during shoulder months when low loads and high humidity occur. In many cases, the combined efforts of refrigeration system compressor multistep control, an interlaced evaporator coil, and the supply fan modulation of SZVAV control are sufficient. The rooftop unit provides an optional modulating hot gas reheat (HGRH) coil to further reduce the humidity level within the space.

### 10. Indoor air quality (IAQ)

To meet the critical needs of IAQ, the rooftop unit provides a stainless steel evaporator drain pan for longevity and to facilitate cleanability. The drain pan can be optionally equipped with an overflow switch to warn of improper drainage and minimize the potential for damage to the conditioned space. Ultraviolet (UV) light banks are also an available option that minimize mold and bacteria growth and assists in keeping the evaporator coil clean.

### 11. Energy recovery wheel (ERW)- see Figure 11

The rooftop unit provides an option for an ERW as an integral part of the unit. This device uses exhaust air to condition the fresh air brought into the unit and the conditioned space, increasing the overall rooftop efficiency. As a factory-installed option, the ERW ensures reliability, minimizes field labor, and simplifies long-term maintenance of the device. On 60 ton to 80 ton units, an ERW is provided with dual exhaust fans.

### 12. Airflow flexibility

Whether a rooftop unit is mounted on a roof or on a grade, the orientation of airflow from the rooftop to

the conditioned space and vice versa is important. The Premier units were specifically designed to provide discharge airflow either at the bottom, top, left, or right.

Similarly, the return airflow is designed for maximum flexibility vertically in either direction as well as horizontally in either direction. Depending on selected options, an end return is also possible. This airflow flexibility minimizes installation costs and maximizes possible locations for this flexible rooftop unit.

**Figure 11: ERW 60 ton to 80 ton units**

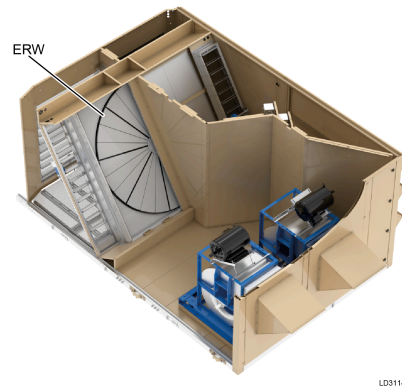

### 13. Split ship

Premier 60 ton to 80 ton units are provided with a split ship option, to meet specific applications where there is constraint for using a higher capacity crane due to unfavorable ground conditions or maneuvering space for the crane to make a safe lift. Split ship units are factory tested, pre-charged with refrigerant and delivered to the job site split in two segments, air handling and condenser section, for an easy lift and seamless integration between power and refrigeration connections. Units which are shipped split are intended to be reconnected into one on a common curb.

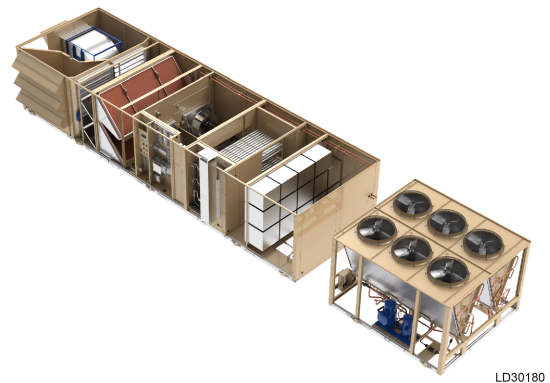

# Nomenclature - 25 ton to 80 ton model number

1 2 3 4 5 6 7 8 9 10 11 12 13 14 15 16 17 18 19 20 21 22 23 24 25 26 27 28 29 30 31 32 33 34 35 36 37 38 39 40 41 42 43 44 45 46 47 48 49  
**G Z A 1 M - 1 B 1 A A - 1 A 6 0 A - A 2 4 1 B - F 2 B B H - 5 C 1 A 1 - B K A G 1 - 0 1 0 1 C - 0 1 0 B C - 0 0 0 1**

## Digits 1-2: Product brand name

GZ: YORK

## Digit 3: Capacity

A: 25 ton  
 B: 30 ton  
 C: 40 ton  
 D: 50 ton  
 F: 60 ton  
 H: 70 ton  
 J: 80 ton

## Digit 4: Efficiency

1: Standard capacity, standard efficiency, staged control  
 2: Standard capacity, high efficiency, modulating control  
 3: High capacity, standard efficiency, staged control  
 4: Standard capacity, standard efficiency, low sound, staged control  
 5: Standard capacity, high efficiency, low sound, modulating control  
 6: High capacity, standard efficiency, low sound, staged control

## Digit 5: Heat source

A: Cooling only  
 B: Staged gas aluminized burner  
 C: Staged gas stainless steel (SST)  
 G: Modulating gas stainless steel  
 K: Steam coil  
 L: Hot water coil  
 M: Electric heat

## Digit 6A: Electric heat capacity

0: None  
 1: Low heat  
 3: High heat  
 4: Low heat with silicon controlled rectifier (SCR)  
 6: High heat with SCR

## Digit 6B: Natural gas heat capacity

0: None  
 1: 250 MBH  
 2: 500 MBH  
 3: 750 MBH  
 4: 1,000 MBH  
 5: 1,250 MBH  
 6: 1,500 MBH

## Digit 6C: Hot water or steam heating coil option

0: None  
 1: Low heat without valves  
 2: Low heat with valves  
 3: High heat without valves  
 4: High heat with valves

## Digit 7: Unit type

A: Single zone VAV (SZVAV) (no duct pressure transducer)  
 B: Variable air volume (VAV) (duct pressure transducer)

## Digit 8: Motor control options

1: Supply fan variable frequency drive (VFD)  
 2: Supply fan VFD with line reactor  
 3: Supply fan VFD with bypass (redundant VFD) / Supply fan with dual VFD  
 4: Supply fan VFD with line reactor and bypass (redundant VFD) / Supply fan with dual VFD with line reactor  
 5: Supply fan VFD and return/exhaust fan VFD / (60-80 Ton with ERW) - supply fan VFD and dual exhaust fan option with individual VFD on each exhaust fan  
 6: Supply fan VFD with line reactor and return/exhaust fan VFD with line reactors / (60-80 Ton with ERW) - supply fan VFDs with line reactor and dual exhaust fan option with individual VFD and line reactor on each exhaust fan  
 7: Supply fan VFD and return/exhaust fan VFD with bypass (redundant VFD for supply fan and bypass for return/exhaust fan) / Supply fan with dual VFD and redundant VFD for return fan / manual bypass for exhaust fan / (60-80 Ton with ERW) - supply fan with dual VFD and dual exhaust fan option with individual VFD on each exhaust fan  
 8: Supply fan VFD with line reactor and return/exhaust fan VFD with line reactor with bypass (redundant VFD for supply fan and bypass for return or exhaust fan / Supply fan with dual VFD and redundant VFD for return fan / manual bypass for exhaust fan, and line reactors (for all fans) / (60-80 Ton with ERW) - supply fan with dual VFD with line reactors and dual exhaust fan option with individual VFD and line reactor on each exhaust fan

## Digit 9: Voltage

A: 208-230 V 3Ph 60 Hz, single point terminal block  
 B: 208-230 V 3Ph 60 Hz, dual point terminal block  
 C: 208-230 V 3Ph 60 Hz, single point non-fused DISC  
 D: 208-230 V 3Ph 60 Hz, single point terminal block, 65KA short-circuit current rating (SCCR)  
 E: 208-230 V 3Ph 60 Hz, dual point terminal block, 65KA SCCR  
 F: 208-230 V 3Ph 60 Hz, single point fused DISC, 65KA SCCR  
 G: 460 V 3Ph 60 Hz, single point terminal block  
 H: 460 V 3Ph 60 Hz, dual point terminal block  
 J: 460 V 3Ph 60 Hz, single point non-fused DISC  
 K: 460 V 3Ph 60 Hz, single point terminal block, 65KA SCCR  
 L: 460 V 3Ph 60 Hz, dual point terminal block, 65KA SCCR  
 M: 460 V 3Ph 60 Hz, single point fused DISC, 65KA SCCR  
 N: 575 V 3Ph 60 Hz, single point terminal block  
 P: 575 V 3Ph 60 Hz, dual point terminal block  
 Q: 575 V 3Ph 60 Hz, single point non-fused DISC  
 R: 575 V 3Ph 60 Hz, single point terminal block, 65KA SCCR  
 S: 575 V 3Ph 60 Hz, dual point terminal block, 65KA SCCR  
 T: 575 V 3Ph 60 Hz, single point fused DISC, 65KA SCCR

## Digit 10: Return configuration

A: Bottom return, right outside air (OA), side exhaust  
 B: Bottom return, right OA, front exhaust  
 C: Bottom return, left OA, side exhaust  
 D: Bottom return, left OA, front exhaust

E: Top return, right OA, side exhaust (no return fan available)  
 F: Top return, right OA, front exhaust (no return fan available)  
 G: Top return, left OA, side exhaust (no return fan available)  
 H: Top return, left OA, front exhaust (no return fan available)  
 J: Left return, right OA, front exhaust  
 K: Right return, left OA, front exhaust  
 L: Front return, left OA, right exhaust  
 M: Front return, right OA, left exhaust  
 N: Bottom return, no OA, no exhaust air (EA) (no return fan available)  
 P: Top return, no OA, no EA (no return fan available)  
 Q: Left return, no OA, no EA (no return fan available)  
 R: Right return, no OA, no EA (no return fan available)  
 S: Front return, no OA, no EA (no return fan available)

## Digit 11: Discharge locations

1: Bottom discharge, from discharge plenum  
 2: Bottom discharge, discharge through heat section  
 3: Top discharge, from discharge plenum  
 4: Right discharge, from discharge plenum  
 5: Left discharge, from discharge plenum  
 6: Left discharge, discharge through heat section

## Digit 12: Supply configuration

A: None  
 B: Small blank  
 C, D: Large blank  
 E, G: Large blank with final filter  
 F: Small blank with humidifier and SST drain pan  
 H, K: Large blank with humidifier and SST drain pan  
 L: Small blank sound attenuator  
 M, N: Large blank sound attenuator  
 P: Small blank final filter  
 Q, T: Large blank with sound attenuator and final filter  
 S, V: Large blank with sound attenuator and humidifier and SST drain pan

## Digit 13: Final filter options

1: MERV 15 bag final filters with 2 in. MERV 8 filters  
 2: MERV 14 rigid final filters with 2 in. MERV 8 filters  
 3: MERV 17 high efficiency particulate air (HEPA) final filters with 2 in. MERV 8 filters  
 4: MERV 14/15 filter rack (no filters)  
 5: HEPA filter rack (no filters)  
 6: None

## Digit 14: Final filter control options

0: None  
 1: Combined pre- and post- filter transducer  
 2: Separate pre- and post- filter transducer  
 3: Combined pre- and post- filter transducer and combined magnehelic gauge

- 4: Separate pre- and post- filter transducer and magnehelic gauge
- 5: Combined pre- and post- filter magnehelic gauge
- 6: Separate pre- and post- filter magnehelic gauge
- 7: Combined pre- and post- filter transducer, separate pre- and post- filter magnehelic gauge

**Digit 15: Supply fan**

- A: Direct drive plenum (DDP) supply fan with 1 in. spring isolation
- B: DDP supply fan with 2 in. spring isolation
- C: DDP supply fan with 2 in. spring isolation and seismic restraint
- D: Dual direct drive plenum supply fans with 1 in. spring isolation
- E: Dual direct drive plenum supply fans with 2 in. spring isolation
- F: Dual direct drive plenum supply fans with 2 in. spring isolation and seismic restraint

**Digit 16: Supply fan motor horsepower**

- A: 5 HP / 5 HP x 2
- B: 7.5 HP / 7.5 HP x 2
- C: 10 HP / 10 HP x 2
- D: 15 HP / 15 HP x 2
- E: 20 HP / 20 HP x 2
- F: 25 HP / 25 HP x 2
- G: 30 HP / 30 HP x 2
- H: 40 HP / 40 HP x 2
- J: 50 HP

**Digit 17: Supply fan motor type**

- 2: ODP premium efficiency 1,800 RPM
- 4: TEFC premium efficiency 1,800 RPM

**Digit 18: Supply fan options**

- 0: None
- 1: Inlet guard
- 2: Airflow measurement station
- 3: Shaft grounding ring
- 4: Inlet guard and airflow measurement station
- 5: Inlet guard and shaft grounding ring
- 6: Airflow measurement station and shaft grounding ring
- 7: Shaft Grounding Ring, Inlet Guard and Airflow Measurement Station

**Digits 19: Building pressure control**

- 0: None
- 1: Barometric damper
- 2: Exhaust with VFD and backdraft damper
- 3: Modulating damper (on/off exhaust fan only without VFD)
- 4: Modulating damper (return fan only with VFD)

**Digit 20: Return/exhaust fan**

- A: None
- B: Exhaust fan with 1 in. spring isolation
- C: Exhaust fan with 2 in. spring isolation
- D: Exhaust fan with 2 in. spring isolation and seismic restraint
- E: Return fan with 1 in. spring isolation
- F: Return fan with 2 in. spring isolation
- G: Return fan with 2 in. spring isolation and seismic restraint
- H: DDP return fan with 1 in. spring isolation
- J: DDP return fan with 2 in. spring isolation
- K: DDP return fan, fan with 2 in. spring isolation and seismic restraint

- L: Dual forward curved exhaust fan with 1 in. spring isolation
- M: Dual forward curved exhaust fan with 2 in. spring isolation
- N: Dual forward curved exhaust fan with 2 in. spring isolation and seismic restraint

**Digit 21: Return/exhaust fan motor horsepower**

- A: No return/exhaust fan
- E: 3 HP
- F: 5 HP
- G: 7.5 HP
- H: 10 HP
- J: 15 HP
- K: 20 HP
- L: 25 HP
- M: 30 HP
- N: 40 HP

- 1: 5 HP x 2
- 2: 7.5 HP x 2
- 3: 10 HP x 2
- 4: 15 HP x 2
- 5: 20 HP x 2

**Digit 22: Return/exhaust fan motor type**

- 0: None
- 1: ODP premium efficiency 1,200 RPM
- 2: ODP premium efficiency 1,800 RPM
- 3: TEFC premium efficiency 1,200 RPM
- 4: TEFC premium efficiency 1,800 RPM

**Digit 23: Return/exhaust fan options**

- A: None
- B: Shaft grounding ring
- C: Extended grease lines
- D: Extended grease lines and shaft grounding ring
- E: Belt guards
- F: Belt guards and shaft grounding ring
- G: Return fan airflow measurement station
- H: Return fan airflow measurement station and shaft grounding ring
- J: Extended grease lines and belt guards
- K: Extended grease lines and belt guards and shaft grounding ring
- L: Extended grease lines and return fan airflow measurement station
- M: Extended grease lines and return fan airflow measurement station and shaft grounding
- N: Belt guards and return fan airflow measurement station
- P: Belt guards and return fan airflow measurement station and shaft grounding ring
- Q: Extended grease lines and belt guards and return fan airflow measurement station
- R: Extended grease lines and belt guards and return fan airflow measurement station and shaft grounding ring

**Digits 24: Return/exhaust fan drive**

- A: None (25-50 ton)
- 0: None (60-80 ton)
- 1-9: RPM
- A-Z: RPM

**Digit 25: Evaporator options**

- G: Aluminum fin evaporator with SST drain pan

- H: Aluminum fin evaporator with SST drain pan with condensate overflow switch
- J: E-Coat aluminum fin evaporator with SST drain pan
- K: E-Coat aluminum fin evaporator with SST drain pan with condensate overflow switch
- L: Copper fin evaporator with sst drain pan
- M: Copper fin evaporator with SST drain pan with condensate overflow switch

**Digit 26: Condenser coil options**

- 2: With wire guards
- 3: Full louvered panels
- 4: Partial louvered panels with wire guards
- 6: E-Coat condenser with wire guards
- 7: E-Coat condenser, full louvered panels
- 8: E-Coat condenser, partial louvered panels with wire guards

**Digit 27: Draw-through filter options**

- A: Angled filter rack, no filters
- B: Angled filter rack, 2 in. throwaway filters
- C: Angled filter rack, 2 in. MERV 8 filters
- D: Rigid filter rack, no filters
- E: Rigid filter rack, MERV 15 bag filters with 2 in. MERV 8 pre-filters
- F: Rigid filter rack, MERV 14 rigid filters with 2 in. MERV 8 pre-filters
- G: Vertical filter rack, no filters
- H: Vertical filter rack, 4 in. MERV 8 filters

**Digit 28: Draw-through filter control options**

- 0: None
- 1: Combined pre- and post- filter transducer
- 2: Separate pre- and post- filter transducer
- 3: Combined pre- and post- filter transducer and combined magnehelic gauge
- 4: Separate pre- and post- filter transducer and magnehelic gauge
- 5: Combined pre- and post- filter magnehelic gauge
- 6: Separate pre- and post- filter magnehelic gauge
- 7: Combined pre- and post- filter transducer, separate pre- and post- filter magnehelic gauge

**Digit 29: Economizer options**

- A: None
- C: Dry bulb economizer, low leak dampers
- D: Single enthalpy economizer, low leak dampers
- E: Dual enthalpy economizer, low leak dampers
- F: Dry bulb economizer, low leak dampers with airflow measurement station
- G: Single enthalpy economizer, low leak dampers with airflow measurement station
- H: Dual enthalpy economizer, low leak dampers with airflow measurement station
- K: Dry bulb economizer, ultra low leak dampers
- L: Single enthalpy economizer, ultra low leak dampers
- S: Dual enthalpy economizer, ultra low leak dampers
- T: Dry bulb economizer, ultra low leak dampers with airflow measurement station
- U: Single enthalpy economizer, ultra low leak dampers with airflow measurement station
- V: Dual enthalpy economizer, ultra low leak dampers with airflow measurement station

**Digit 30: Energy recovery options**

- 0: None
- 1: Low cubic feet per minute (CFM) energy recovery wheel (ERW) without VFD
- 2: Low CFM ERW with VFD

3: High CFM ERW without VFD

4: High CFM ERW with VFD

#### Digit 31: Refrigeration system piping options

A: None

B: Suction and discharge valves

C: Suction, discharge, and liquid valves

D: Suction, discharge, and liquid valves with replaceable core filter driers

E: Hot gas reheat (HGRH)

F: Suction and discharge valves with HGRH

G: Suction, discharge, and liquid valves with HGRH

H: Suction, discharge, and liquid valves with replaceable core filter driers with HGRH

N: E-Coat HGRH

P: Suction and discharge valves with E-Coat HGRH

Q: Suction, discharge, and liquid valves with E-Coat HGRH

R: Suction, discharge, and liquid valves with replaceable core filter driers with E-Coat HGRH

#### Digit 32: Lights/detectors/ convenience options

A: None

B: Convenience outlet

C: Convenience outlet and internal lights

D: Supply smoke detector

E: Return smoke detector

F: Supply and return smoke detector

G: Convenience outlet with supply smoke detector

H: Convenience outlet with return smoke detector

J: Convenience outlet with supply and return smoke detectors

K: Convenience outlet and internal lights with supply smoke detector

L: Convenience outlet and internal lights with return smoke detector

M: Convenience outlet and internal lights with supply and return smoke detectors

#### Digit 33: Controls options

A: None

B: Low ambient

D: Subcool and superheat measurement

E: Low ambient with subcool and superheat measurement

F: With Verasys

G: Low ambient with Verasys

H: Subcool and superheat measurement with Verasys

I: Low ambient with subcool and superheat measurement with Verasys

#### Digit 34: Interface options

A: BACnet® MS/TP, Modbus™, N2

B: BACnet IP

G: BACnet MS/TP, Modbus, N2 with mobile access portal (MAP)

H: MAP with BACnet IP

K: BACnet MS/TP, Modbus, N2 with MAP and touchscreen

L: Touchscreen with MAP with BACnet IP

N: BACnet MS/TP, Modbus, N2 with customer terminal board

P: BACnet IP with customer terminal board

U: BACnet MS/TP, Modbus, N2 with MAP and customer terminal board

V: MAP with BACnet IP and customer terminal board

X: BACnet MS/TP, Modbus, N2 with touchscreen and MAP and customer terminal board

Y: Touchscreen with MAP with BACnet IP and customer terminal board

#### Digit 35: Indoor air quality (IAQ) options

0: None

1: Ultraviolet (UV) lights

2: Carbon Dioxide (CO<sub>2</sub>) sensors, demand controlled ventilation

3: UV lights, CO<sub>2</sub> sensors, demand controlled ventilation

#### Digit 36: Gas heat shipped loose kits

0: None

1: Gas heat, side penetration

2: Gas heat, bottom penetration

3: Gas heat, high altitude kit natural gas (NG), side penetration

4: Gas heat, high altitude kit NG, bottom penetration

5: Gas heat, high altitude kit liquid propane (LP), side penetration

6: Gas heat, high altitude kit LP, bottom penetration

7: Gas heat, LP conversion kit, side penetration

8: Gas heat, LP conversion kit, bottom penetration

#### Digit 37: Security options

0: None

1: Supply and return opening burglar bars

2: Supply opening burglar bars

3: Return opening burglar bars

#### Digit 38: Door options

0: None

1: Viewport

2: Single handle with padlock

3: Single handle with padlock and viewport

#### Digit 39: Cabinet shipping options

1: Single piece construction

2: Two piece construction

#### Digit 40: Curb options

A: No roof curb

B: Full perimeter roof curb

C: Pedestal curb

#### Digit 41: Pre-evap options

0: None

1, 2: Blank pre-evap extension, no air blender

3, 4: Blank pre-evap extension, with air blender

#### Digit 42: Shipped loose options

0: None

1: Spare belts for return/exhaust

#### Digit 43: Construction standard

0: None

#### Digit 44: Supply fan VFD frequency

1: 68 Hz

2: 70 Hz

3: 72 Hz

A: 66 Hz

B: 64 Hz

C: 62 Hz

D: 60 Hz

E: 58 Hz

F: 56 Hz

G: 54 Hz

H: 52 Hz

J: 50 Hz

K: 48 Hz

L: 46 Hz

M: 44 Hz

N: 42 Hz

P: 40 Hz

Q: 38 Hz

R: 36 Hz

S: 34 Hz

T: 32 Hz

U: 30 Hz

V: 28 Hz

W: 26 Hz

X: 24 Hz

Y: 22 Hz

Z: 20 Hz

#### Digit 45: Supply fan brake horsepower (each motor)

A: 2 HP

B: 3 HP

C: 5 HP

D: 7.5 HP

E: 10 HP

F: 15 HP

G: 20 HP

H: 25 HP

J: 30 HP

K: 40 HP

L: 50 HP

M: 60 HP

N: 75 HP

#### Digit 46: Return fan brake horsepower

B-L : Internal use only

#### Digit 47: Future 4

0: None

#### Digit 48: Testing and special quotation (SQ)

0, Y, Z: None

T: Record test report

M: Mechanical special

1: Mechanical special and record test report

S: Software special

3: Software special and record test report

B: Mechanical and software special

5: Mechanical and software special and record test report

#### Digit 49: Generation/revision level

1: First generation

2: Second generation

# Selection procedure examples

Given:

Required cooling capacity	290,000 Btuh
Required sensible cooling	210,000 Btuh
Required heating	180,000 Btuh
Entering air on evaporator	80.0°F dry bulb (DB)/ 67.0°F wet bulb (WB)
Outside design temperature	95.0°F
Supply fan CFM	12,000 CFM
External static pressure (ESP)	3.97 iwg
Electrical supply voltage	460-3-60
Economizer required	
2 in. throwaway filters	
Variable air volume (VAV)	

## Calculating cooling and heating capacity

- Assume that the required cooling capacity and required sensible capacity include the space load requirements as well as the ventilation load requirements.
- Calculate the supply fan motor heat Btuh addition.
  - See [Select fan speed and horsepower requirements for supply fan](#) to determine the horsepower (HP) of the supply fan. The example is based on a 14.91 HP requirement.
  - Calculate sensible Btuh addition as a result of the supply fan HP.
    - Supply fan sensible Btuh addition = 14.91 HP x 2,750 (constant for motor heat calculation)
    - Supply fan sensible Btuh addition = 41,003 Btuh
  - Calculate wet bulb SAT.
    - Leaving enthalpy = enthalpy entering – enthalpy delta (reference psychometric chart to convert unit wet bulb temperature to Btu/lb)
    - Leaving enthalpy = 31.6 Btu/lb – 6.7 Btu/lb
    - Leaving enthalpy = 24.9 Btu/lb
    - Wet bulb SAT = 57.7°F
- For gas heating capacity, see [Table 130](#).
  - Trace down to the maximum output capacity (MBH) column.

**b.** Find the output that exceeds the 180,000 Btuh requirement.

The 250 MBH output exceeds this requirement.

**c.** This option is available on the 30 ton unit.

From the nomenclature, select digit 5, option B for staged gas, option C for staged gas with stainless steel burner, or option G for modulating gas with stainless steel burner.

From digit 6B, select option 1 for 250 MBH. The resulting model number shows C1 for digits 5 and 6, assuming staged gas with stainless steel burner was selected.

**4.** For electric heating capacity, see [Table 131](#).

**a.** Trace down to the heat capacity (MBH) column.

**b.** Find the output that exceeds the 180,000 Btuh requirement at the given 460-3-60 voltage.

The 60 kW output exceeds this requirement.

**c.** This option is available on the 30 ton unit.

From the nomenclature, select digit 5, option M for electric heat.

From digit 6A, select either option 1 with low staged electric heat or option 4 with low silicon controlled rectifier (SCR) electric heat. The resulting model number shows M4 for digits 5 and 6, assuming low SCR electric heat was selected.

## Select fan speed and horsepower requirements for supply fan

**1.** See [Table 171](#) for the 30 ton unit.

**a.** Make any necessary additions to the static resistance for the ductwork. See [Table 145](#) onwards for component static pressure drops (iwg):

Ductwork static resistance/ESP	3.97 iwg
+ return duct static pressure (assumed)	0.25 iwg
+ economizer static resistance addition	0.33 iwg
+ bottom supply air opening resistance addition	0.09 iwg
+ wet evaporator coil standard capacity static resistance addition	0.69 iwg
+ gas heat (250 MBH)	0.04 iwg
+ throwaway filters	0.13 iwg
Total Static Resistance (TSP)	5.50 iwg

**b.** Enter [Table 171](#) at 12,000 CFM and 5.50 iwg TSP:  
RPM = 1768

BHP = 14.91

2. From the nomenclature, select digit 15, option A to opt for direct drive plenum (DDP) supply fan with 1 in. spring isolation. Select digit 16, option E for 20 HP supply fan motor. Select digit 17, option 2 for ODP premium efficiency, 1,800 RPM.

## Select fan speed and horsepower requirements of exhaust fan with and without ERW for 30 ton to 50 ton, and without ERW for 60 ton to 80 ton

1. See [Table 179](#) for the 30 ton unit. In the following example, a unit is designed for exhaust air capacity of 7,000 CFM.

a. Make any necessary additions to the static resistance. To find the exhaust air damper pressure drop, see [Table 147](#):

Return duct static pressure (assumed)	0.25 iwg
+ exhaust air damper pressure drop	0.33 iwg
TSP	0.58 iwg

---

b. Enter at 7,000 CFM and 0.58 iwg TSP:

RPM = 634 (interpolated)

BHP = 2.72 (interpolated)

2. From the nomenclature, select digit 19, option 2 for exhaust with variable frequency drive (VFD) and backdraft damper; digit 20, option B for the exhaust fan with 1 in. spring isolation; and digit 21, option E for 3 HP exhaust fan motor. The resulting model number shows 2BE for digits 19, 20, and 21.

## Select energy recovery wheel (ERW), hot gas reheat (HGRH), sound attenuator, and humidifier

Refer to Selection Navigator or contact the local sales office for more information on available options and accessories.

## Example model number

The following model number is an example based on the options selected in the previous sections.

**G Z B 1 C - 1 B 5 G A - 1 A 6 0 A - E 2 0 2 B - E 2 A D G - 2 C 0 E 0 - D M A A 3 - 1 0 0 1 A - 0 0 0 C G - 0 0 0 1**

The diagram shows the model number GZB1C-1B5GA-1A60A-E202B-E2ADG-2C0E0-DMAA3-1001A-000CG-0001 with callouts pointing to specific characters. The callouts are: 3 (G), 4 (Z), 5 (B), 6 (1), 7 (C), 8 (5), 9 (G), 15 (A), 16 (6), 17 (0), 19 (A), 20 (E), 21 (2), 22 (0), 27 (D), 29 (M), 31 (A), 32 (A), 35 (3), and 49 (1).

- 3. Capacity 30 ton
- 4. Standard capacity, standard efficiency
- 5. Staged gas stainless steel
- 6. 250 MBH
- 7. Variable air volume
- 8. Supply fan with VFD and return and exhaust fan with VFD
- 9. 460 V 3Ph 60 Hz, single point terminal block
- 15. Direct drive plenum supply fan with 1 in. spring isolation
- 16. Supply fan motor, 20 HP
- 17. Supply fan motor type, ODP premium efficiency 1,800 RPM
- 19. Exhaust fan with VFD and backdraft damper
- 20. Forward curved exhaust fan with 1 in. spring isolation
- 21. Exhaust fan motor, 3 HP
- 22. Exhaust fan motor type, ODP premium efficiency 1,800 RPM
- 27. Pre-evaporator filter, angled filter rack, 2 in. MERV 8 filters
- 29. Dual enthalpy economizer, low leak dampers
- 31. Suction, discharge, and liquid line valves with replaceable core filter driers
- 32. Convenience outlet and internal lights with supply and return smoke detectors
- 35. Ultraviolet (UV) lights and Carbon Dioxide (CO<sub>2</sub>) sensors
- 49. First generation

# Physical data

**Table 1: Physical data**

Unit size	25 ton	30 ton	40 ton	50 ton	60 ton	70 ton	80 ton
<b>Compressor data - standard capacity, standard efficiency</b>							
Quantity/size (nominal HP)	1/4.5, 1/7, 1/10	1/5.5, 1/7, 1/7.5	1/5.5, 1/8.5, 1/10, 1/11.5	1/7.5, 1/10, 1/11.5, 1/15	1/12, 1/12, 1/15, 1/15	1/10, 1/15, 1/15, 1/20	1/15, 1/15, 1/15, 1/20
Type	Scroll	Scroll	Scroll	Scroll	Scroll	Scroll	Scroll
Capacity steps	7	11	15	15	8	9	7
Number of circuits	2	2	2	2	2	2	2
<b>Compressor data - high capacity, standard efficiency</b>							
Quantity/size (nominal HP)	1/5, 1/7.5, 1/10	1/5.5, 1/7, 1/7, 1/8.5	1/7, 1/13, 1/8.5, 1/10	1/8.5, 1/15, 1/7.5, 1/15	1/13, 1/13, 1/15, 1/15	1/15, 1/15, 1/15, 1/20	1/15, 1/15, 1/20, 1/20
Type	Scroll	Scroll	Scroll	Scroll	Scroll	Scroll	Scroll
Capacity steps	7	11	15	11	8	7	8
Number of circuits	2	2	2	2	2	2	2
<b>Compressor data - standard capacity, high efficiency</b>							
Quantity/size (nominal HP)	1/5, 1/7.5, 1/13	1/7, 1/7, 1/18.5	1/7.5, 1/7.5, 1/10, 1/13	1/10, 1/10, 1/12, 1/17.5	1/10, 1/15, 1/15, 1/17.5	1/13, 1/15, 1/15, 1/27	1/15, 1/15, 1/15, 1/27
Type	Scroll	Scroll	Scroll	Scroll	Scroll	Scroll	Scroll
Capacity steps	15-100%	15-100%	15-100%	15-100%	15-100%	15-100%	15-100%
Number of circuits	2	2	2	2	2	2	2
<b>Supply fan</b>							
Quantity of fans/motors	1/1	1/1	1/1	1/1	2/2	2/2	2/2
Type	Direct-driven plenum						
Size (in.)	27	27	33	33	27	27	27
Motor size range each fan (min to max HP)	5-25	5-25	10-50	10-50	5-40	5-40	5-40
Airflow range (min to max CFM)	5,000-12,000	5,000-12,000	8,000-20,000	8,000-20,000	12,000-24,000	14,000-32,000	14,000-32,000
Total static pressure range (min to max iwg)	1.0-8.0	1.0-8.0	1.0-8.0	1.0-8.0	1-8.3	1-8.3	1-8.3
<b>Return fan</b>							
Quantity of fans/motors	1/1	1/1	1/1	1/1	1/1	1/1	1/1
Type	Belt-driven plenum			Direct-driven plenum			
Size (in.)	27	27	30	30	33	33	33
Motor size range (min to max HP)	5-10	5-10	5-20	5-20	7.5-40	7.5-40	7.5-40
Airflow range (min to max CFM)	5,000-12,000	5,000-12,000	8,000-20,000	8,000-20,000	12,000-24,000	14,000-32,000	14,000-32,000
Total static pressure range (min to max iwg)	0.5-3.0	0.5-3.0	0.5-3.0	0.5-3.0	0.5-3.0	0.5-3.0	0.5-3.0
<b>Exhaust fan</b>							
Quantity of fans/motors	1/1	1/1	1/1	1/1	1/1	1/1	1/1
Type	Belt-driven forward curved						
Size (in.)	18-18	18-18	25-25	25-25	30-30	30-30	30-30
Motor size range (min to max HP)	3-15	3-15	5-20	5-20	5-25	5-40	5-40
Airflow range (min to max CFM)	5,000-12,000	5,000-12,000	8,000-20,000	8,000-20,000	12,000-24,000	14,000-32,000	14,000-32,000
Total static pressure range (min to max iwg)	0.5-3.0	0.5-3.0	0.5-3.0	0.5-3.0	0.5-3.0	0.5-3.0	0.5-3.0

Unit size	25 ton	30 ton	40 ton	50 ton	60 ton	70 ton	80 ton
<b>ERW dual exhaust fan</b>							
Quantity of fans/motors					2/2	2/2	2/2
Type	Belt-driven forward curved						
Size (in.)			20-18	22-20	22-20		
Motor size range each fan (min to max HP)			5-15	5-20	5-20		
Airflow range (min to max CFM)			6000-24000	7000-28000	7000-32000		
Total static pressure range (min to max iwg)			0.5-3	0.5-3	0.5-3		
<b>Condenser fan</b>							
Quantity	2		4		6		
Type	Propeller						
Size (diameter in in.)	30						
Power (HP)	2						
<b>Evaporator coil - standard capacity, standard efficiency</b>							
Size (sq. ft.)	24		36		49.5	66	66
Number of rows/fins per in.	3/17	5/17	4/17	4/17	5/17	5/17	6/17
Size (tube diameter in in.)	3/8						
<b>Evaporator coil - high capacity, standard efficiency</b>							
Size (sq. ft.)	24		36		49.5	66	66
Number of rows/fins per in.	4/17	6/17	4/17	6/17	6/17	6/17	6/17
Size (tube diameter in in.)	3/8						
<b>Evaporator coil - standard capacity, high efficiency</b>							
Size (sq. ft.)	24		36		49.5	66	66
Number of rows/fins per in.	4/17	6/17	4/17	6/17	6/17	6/17	6/17
Size (tube diameter in in.)	3/8						
<b>Hot gas reheat (HGRH) coil</b>							
Coil type	Microchannel						
Control type	Modulating						
Size (area in sq. ft./thickness in in.)	19.5/0.8		19.5/1		28/1	33.4/1	33.4/1
Number of rows/fins per in.	1/23						
<b>Minimum outside air (OA) temperature for mechanical cooling</b>	45.0°F						
<b>Low ambient option minimum OA temperature for mechanical cooling</b>	-10.0°F						
<b>Condenser coil - standard capacity, standard efficiency</b>							
Size (sq. ft.)	61	61	98	98	153	191	191
Number of rows/fins per in.	1/23	1/23	1/23	1/23	1/23	1/23	1/23
Size (thickness in in.)	0.8	0.8	0.8	1	1	1	1
Type	Microchannel						
<b>Condenser coil - high capacity, standard efficiency</b>							
Size (sq. ft.)	61	61	98	98	153	191	191
Number of rows/fins per in.	1/23						
Size (thickness in in.)	0.8	0.8	0.8	1	1	1	1
Type	Microchannel						
<b>Condenser coil - standard capacity, high efficiency</b>							
Size (sq. ft.)	61	61	98	98	153	191	191
Number of rows/fins per in.	1/23						
Size (thickness in in.)	1						
Type	Microchannel						

Unit size	25 ton	30 ton	40 ton	50 ton	60 ton	70 ton	80 ton
<b>ERW - high CFM</b>							
Cassette dimensions (L x W x H in in.)	50 x 4.36 x 50	50 x 4.36 x 50	62.42 x 6.07 x 62.42	62.42 x 6.07 x 62.42	78 x 7.07 x 78	85 x 7.07 x 85	85 x 7.07 x 85
Wheel segments	6	6	8	8	8	8	8
Motor (V, ph, Hz)	208-230/3/60, 460/3/60, 575/3/60						
Horsepower (HP)	1/6	1/6	1/4	1/4	1/3	1/3	1/3
Filter type	2 in. MERV 8 pleated						
RA filters - size (number)	25 x 25 (2)	25 x 25 (2)	15 x 20 (6)	15 x 20 (6)	18 x 25 (3) and 20 x 25 (3)	20 x 24 (6) and 20 x 10 (2)	20 x 24 (6) and 20 x 10 (2)
OA filters - size (number)	25 x 25 (2)	25 x 25 (2)	15 x 20 (6)	15 x 20 (6)	18 x 25 (3) and 20 x 25 (3)	20 x 24 (6) and 20 x 10 (2)	20 x 24 (6) and 20 x 10 (2)
<b>ERW - low CFM</b>							
Cassette dimensions (L x W x H in in.)	44 x 4.36 x 44	44 x 4.36 x 44	56.19 x 4.36 x 56.19	56.19 x 4.36 x 56.19	68 x 6.07 x 68	72 x 7.07 x 72	72 x 7.07 x 72
Wheel segments	6	6	6	6	8	8	8
Motor (V/ph/Hz)	208-230/3/60, 460/3/60, 575/3/60						
Horsepower (HP)	1/6	1/6	1/6	1/6	1/4	1/4	1/4
Filter type	2 in. MERV 8 pleated						
RA filters - size (number)	25 x 25 (2)	25 x 25 (2)	15 x 20 (6)	15 x 20 (6)	16 x 24 (6)	18 x 24 (6)	18 x 24 (6)
OA filters - size (number)	25 x 25 (2)	25 x 25 (2)	15 x 20 (6)	15 x 20 (6)	16 x 24 (6)	18 x 24 (6)	18 x 24 (6)
<b>Electric heat (208 V/230 V)</b>							
Size range - low/high (kW)	50/100		60/120		90/120		
Heating steps - low/high	3/6		4/8		6/8		
SCR (modulating heat)	Available						
<b>Electric heat (460 V/575 V)</b>							
Size range - low/high (kW)	60/120		80/160		120/200		
Heating steps - low/high	3/6		4/8		6/10		
SCR (modulating heat)	Available						
<b>Gas furnace</b>							
Staged furnace sizes (input/output/stages)	250/202.5/2		500/405/2		500/405/2		
	500/405/2		750/607.5/4		1000/810/4		
	750/607.5/4		1,250/1012.5/6		1500/1215/6		
Airflow range (min to max CFM)	5,000-12,000		8,000-20,000		12,000-24,000	14,000-32,000	14,000-32,000
Gas heat steady state efficiency (SSE)	81%						
Modulating furnace sizes (input/output/turndown)	250/202.5/10:1		500/405/20:1		500/405/10:1		
	500/405/20:1		750/607.5/30:1		1000/810/20:1		
	750/607.5/30:1		1,250/1012.5/50:1		1500/1215/30:1		
Airflow range (min to max CFM)	5,000-12,000		8,000-20,000		12,000-24,000	14,000-32,000	14,000-32,000
<b>Hot water coil</b>							
Coil tube diameter (in.)	1/2						
Material	Copper tube/aluminum fin						
Fins per in. - low/high	13/10		13/10		14/10		
Size (H x L in in.)/rows low	25 x 70/1		42.5 x 70/1		52.5 x 84/1		
Size (H x L in in.)/rows high	25 x 70/2		42.5 x 70/2		52.5 x 84/2		
<b>Steam coil</b>							
Coil tube diameter (in.)	1						
Material	Copper tube/aluminum fin						
Fins per in. - low/high	8/14					10/14	
Size (H x L in in.)/rows low	24 x 68/1		42 x 68/1		48 x 84/1		
Size (H x L in in.)/rows high	24 x 68/1		42 x 68/1		48 x 84/1		

Unit size	25 ton	30 ton	40 ton	50 ton	60 ton	70 ton	80 ton
<b>Draw-through - 2 in. throwaway angled filters</b>							
Quantity	18		24			28	
Size (L x W in in.)	16 x 20		16 x 20			16 x 24	
Total filter face area (sq. ft.)	40		53.33			70.83	
<b>Draw-through - 2 in. MERV 8 angled filters</b>							
Quantity	18		24			28	
Size (L x W in in.)	16 x 20		16 x 20			16 x 24	
Total filter face area (sq. ft.)	40		53.33			70.83	
<b>Draw-through - MERV 15 bag filters with 2 in. MERV 8 pre-filters</b>							
Pre-filters	Quantity	6/6	12/3	9/6			
	Size (L x W in in.)	16 x 24/16 x 20	16 x 24/12 x 24	24 x 24/20 x 24			
	Total filter face area (sq. ft.)	29.33	38	53.61			
Bag filters	Quantity	3/3/2/2	6/7/2	9/6			
	Size (L x W in in.)	24x24/24x20/12x20/12x24	24x24/12x24/12x12	24 x 24/20 x 24			
	Total filter face area (sq. ft.)	29.33	40	53.02			
<b>Draw-through - MERV 14 rigid filters with 2 in. MERV 8 pre-filters</b>							
Pre-filters	Quantity	6/6	12/3	9/6			
	Size (L x W in in.)	16 x 24/16 x 20	16 x 24/12 x 24	24 x 24/20 x 24			
	Total filter face area (sq. ft.)	29.33	38	53.61			
Rigid filters	Quantity	3/4/1	6/3/2/1	9/6			
	Size (L x W in in.)	24 x 24/24 x 20/20 x 20	24 x 24/12 x 24/20 x 24/12 x 20	24 x 24/20 x 24			
	Total filter face area (sq. ft.)	28.11	38.33	53.02			
<b>Draw-through - vertical 4 in. MERV 8 filters</b>							
Quantity	6/6	18	9/6				
Size (L x W in in.)	16 x 25/16 x 20	16 x 20	24 x 24/20 x 24				
Total filter face area (sq. ft.)	30	40	53.02				
<b>Final filters - MERV 15 bag filters with 2 in. pre-filters</b>							
Pre-filters	Quantity	6/4	12/3	6/8			
	Size (L x W in in.)	16 x 24/20 x 20	16 x 24/12 x 24	24 x 24/20 x 24			
	Total filter face area (sq. ft.)	27.11	38	48.47			
Bag filters	Quantity	3/4/2	6/7	6/4/4			
	Size (L x W in in.)	24 x 24/20 x 20/12 x 24	24 x 24/12 x 24	24 x 24/24 x 20/20 x 24			
	Total filter face area (sq. ft.)	27.11	38	47.93			

Unit size		25 ton	30 ton	40 ton	50 ton	60 ton	70 ton	80 ton
<b>Final filters - MERV 14 rigid filters with 2 in. pre-filters</b>								
Pre-filters	Quantity	6/4		12/3		6/8		
	Size (L x W in in.)	16 x 24/20 x 20		16 x 24/12 x 24		24 x 24/20 x 24		
	Total filter face area (sq. ft.)	27.11		38		48.47		
Rigid filters	Quantity	3/4/2		6/7		9/6		
	Size (L x W in in.)	24 x 24/20 x 20/12 x 24		24 x 24/12 x 24		24 x 24/20 x 24		
	Total filter face area (sq. ft.)	27.11		38		53.02		
<b>Final filters - MERV 17 HEPA® filters with 2 in. pre-filters</b>								
Pre-filters	Quantity	6/4		12/3		6/8		
	Size (L x W in in.)	16 x 24/20 x 20		16 x 24/12 x 24		24 x 24/20 x 24		
	Total filter face area (sq. ft.)	27.11		38		48.47		
HEPA® filters	Quantity	6		15/3		8/8/2		
	Size (L x W in in.)	24 x 24		12 x 24/12 x 17		23-3/8 x 23-3/8/24 x 12/12 x 12		
	Total filter face area (sq. ft.)	24		34.26		48.36		

## Capacity performance

Energy efficiency ratio and integrated energy efficiency ratio (EER/IEER) ratings

**Table 2: EER/IEER ratings**

Capacity	Efficiency	Heat source	EER	IEER
25 ton	Standard capacity/standard efficiency	Cooling only/electric heat	10.8	14.9
		Gas/steam/hot water	10.6	14.8
	Standard capacity/high efficiency	Cooling only/electric heat	11.4	16.7
		Gas/steam/hot water	11.2	16.6
	High capacity/standard efficiency	Cooling only/electric heat	10.8	14.9
		Gas/steam/hot water	10.6	14.8
30 ton	Standard capacity/standard efficiency	Cooling only/electric heat	10.5	14.3
		Gas/steam/hot water	10.3	14.2
	Standard capacity/high efficiency	Cooling only/electric heat	10.9	15.2
		Gas/steam/hot water	10.7	15.1
	High capacity/standard efficiency	Cooling only/electric heat	10.5	14.3
		Gas/steam/hot water	10.3	14.2
40 ton	Standard capacity/standard efficiency	Cooling only/electric heat	10.9	14.6
		Gas/steam/hot water	10.7	14.5
	Standard capacity/high efficiency	Cooling only/electric heat	11.1	16.1
		Gas/steam/hot water	10.9	16.0
	High capacity/standard efficiency	Cooling only/electric heat	10.7	14.6
		Gas/steam/hot water	10.5	14.5
50 ton	Standard capacity/standard efficiency	Cooling only/electric heat	10.8	15.0
		Gas/steam/hot water	10.6	14.9
	Standard capacity/high efficiency	Cooling only/electric heat	10.9	15.9
		Gas/steam/hot water	10.7	15.8
	High capacity/standard efficiency	Cooling only/electric heat	10.5	14.8
		Gas/steam/hot water	10.3	14.7
60 ton	Standard capacity/standard efficiency	Cooling only/electric heat	10.5	15.8
		Gas/steam/hot water	10.3	15.6
	Standard capacity/high efficiency	Cooling only/electric heat	10.8	16.9
		Gas/steam/hot water	10.6	16.7
	High capacity/standard efficiency	Cooling only/electric heat	10.5	15.8
		Gas/steam/hot water	10.3	15.6

## Altitude and temperature correction factors

**Table 3: Altitude and temperature correction factors**

Air temp (°F)	Altitude (ft)										
	0*	1,000	2,000	3,000	4,000	5,000	6,000	7,000	8,000	9,000	10,000
40	1.060	1.022	0.986	0.95	0.916	0.822	0.849	0.818	0.788	0.758	0.729
50	1.039	1.002	0.966	0.931	0.898	0.864	0.832	0.802	0.772	0.743	0.715
60	1.019	0.982	0.948	0.913	0.880	0.848	0.816	0.787	0.757	0.729	0.701
70	1.000	0.964	0.930	0.896	0.864	0.832	0.801	0.772	0.743	0.715	0.688
80	0.982	0.947	0.913	0.88	0.848	0.817	0.787	0.758	0.73	0.702	0.676
90	0.964	0.929	0.897	0.864	0.833	0.802	0.772	0.744	0.716	0.689	0.663
100	0.946	0.912	0.880	0.848	0.817	0.787	0.758	0.730	0.703	0.676	0.651

① **Note:**

\* Correction factors at sea level to calculate for actual temperature conditions.

The information below must be used to assist in application of product when applied at altitudes equal to or above 1000 ft above sea level.

The following examples assist in determining the airflow performance of Premier units at specific altitudes.

**Example 1:** What are the corrected cubic ft per minute (CFM), static pressure, and brake horse power (BHP) at an elevation of 5,000 ft if the airflow performance data is 6,000 CFM, 1.4 in. of water gauge (iwg), and 2.0 BHP?

**Solution:** At an elevation of 5,000 ft, the supply fan still delivers 6,000 CFM if the revolutions per minute (RPM) is unchanged. However, the altitude correction must be used to determine the static pressure and BHP. Since no temperature data is given, we assume an air temperature of 70.0°F. [Table 3](#) shows the correction factor to be 0.832.

Corrected static pressure =  $1.4 \times 0.832 = 1.16$  iwg

Corrected BHP =  $2.0 \times 0.832 = 1.66$

**Example 2:** A system, located at 5,000 ft of elevation is to deliver 6,000 CFM at a static pressure of 1.4 iwg. Use the unit blower tables to select the RPM, blower speed, and the BHP requirement.

**Solution:** As in the example above, no temperature information is given, so 70.0°F is assumed.

The 1.4 iwg static pressure given is at an elevation of 5,000 ft. The first step is to convert this static pressure to equivalent sea level conditions.

Sea level static pressure =  $1.4 \text{ iwg} / 0.832 = 1.68$  iwg

Enter [Table 171](#) at 6,000 CFM and static pressure of 1.68 iwg. The RPM listed is the same RPM needed at 5,000 ft.

Using interpolation, the corresponding BHP listed in the table is 2.25. This value must be corrected for elevation.

BHP at 5,000 ft =  $2.25 \times 0.832 = 1.87$

**Example 3:** Plot fan performance using [Table 145](#).

Plot the fan performance at cooling sea level (0 ft) elevation. Design conditions are a 25 ton unit producing 10,000 CFM at 1.5 external static pressure (ESP) with additional static losses for a wet evaporator coil, bottom return air, bottom supply air, outside air, and angled filter rack with 2 in. MERV 8 filters. Refer to [Table 145](#) onwards for component static pressure drops (iwg)

Wet evaporator coil standard capacity additional static loss = 0.41 iwg

Bottom return air additional static loss = 0.05 iwg

Bottom supply air additional static loss = 0.06 iwg

Outside air additional static loss = 0.30 iwg

Air filter additional static loss = 0.11 iwg

Add the ESP and all additional losses (internal static loss):

ESP loss = 1.5 iwg

Total internal static loss = 0.93 iwg

Total system static = 2.43 iwg

Figure 12: 25 ton unit fan performance

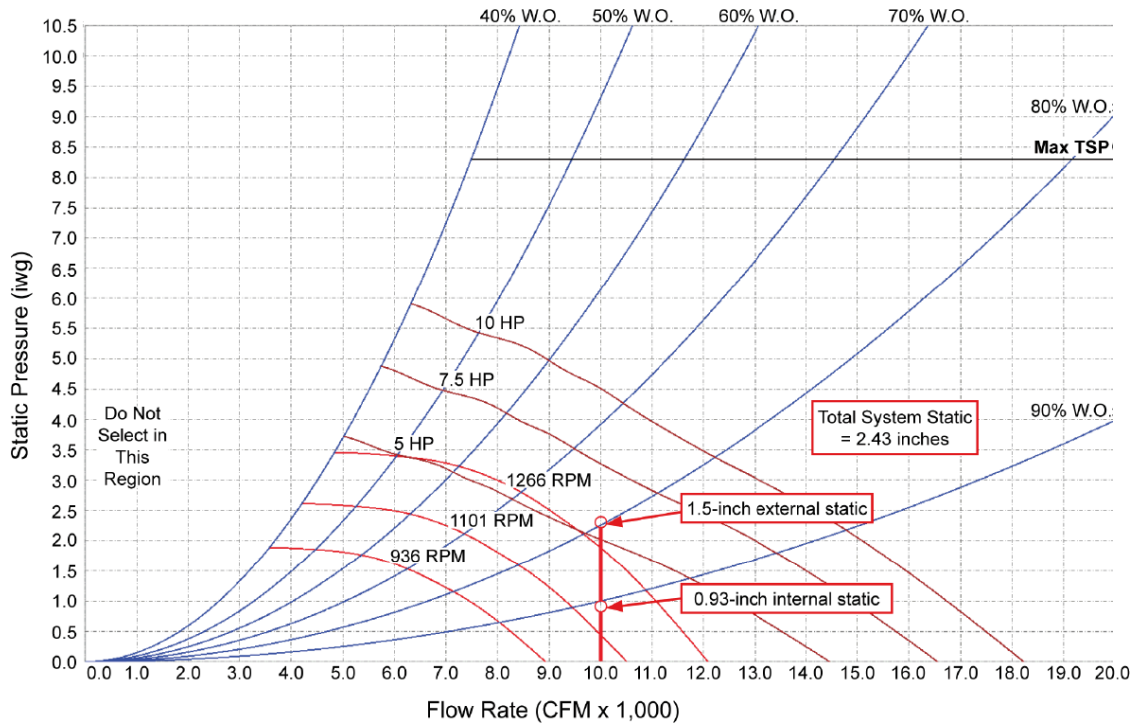

LD26887

# Cooling performance data

## Cooling performance data 25 ton standard efficiency

**Table 4: 25 ton standard efficiency - 75°F ambient air temperature**

CFM	EWB (°F)	95°F EDB			90°F EDB			85°F EDB			80°F EDB			75°F EDB			70°F EDB			65°F EDB		
		TMBH	SMBH	kW	TMBH	SMBH	kW	TMBH	SMBH	kW	TMBH	SMBH	kW	TMBH	SMBH	kW	TMBH	SMBH	kW	TMBH	SMBH	kW
5,000	77	335	199	20	334	172	20	333	144	20	332	116	20	-	-	-	-	-	-	-	-	-
	72	306	227	20	306	200	20	305	172	20	304	145	20	303	117	20	-	-	-	-	-	-
	67	281	254	19	280	227	19	279	200	19	278	173	19	277	145	19	276	118	19	-	-	-
	62	269	269	19	-	-	-	-	-	-	-	-	-	-	-	-	-	-	-	-	-	-
	57	269	269	19	-	-	-	-	-	-	-	-	-	-	-	-	-	-	-	-	-	-
6,750	77	360	237	20	358	200	20	357	163	20	355	125	20	-	-	-	-	-	-	-	-	-
	72	331	274	20	330	238	20	328	201	20	327	164	20	326	127	20	-	-	-	-	-	-
	67	310	308	20	304	274	19	302	238	19	301	202	19	299	165	19	298	128	19	-	-	-
	62	309	309	20	293	293	19	280	274	19	276	238	19	275	202	19	273	165	19	272	128	19
	57	308	308	20	293	293	19	278	278	19	263	263	19	-	-	-	-	-	-	-	-	-
8,500	77	-	-	-	373	226	20	372	180	20	370	133	20	-	-	-	-	-	-	-	-	-
	72	349	319	20	345	273	20	343	227	20	342	181	20	339	135	20	-	-	-	-	-	-
	67	339	339	20	323	318	20	318	274	20	314	228	20	313	182	20	311	136	20	-	-	-
	62	339	339	20	321	321	20	304	304	19	292	274	19	288	228	19	287	183	19	285	136	19
	57	338	338	20	321	321	20	303	303	19	287	287	19	270	270	19	264	228	19	262	183	19
10,250	77	-	-	-	-	-	-	-	-	-	-	-	-	-	-	-	-	-	-	-	-	-
	72	365	359	20	357	308	20	353	253	20	352	197	20	349	142	20	-	-	-	-	-	-
	67	363	363	20	344	344	20	330	308	20	325	253	20	323	198	20	321	143	20	-	-	-
	62	362	362	20	343	343	20	324	324	20	306	305	20	298	254	19	296	199	19	294	144	19
	57	362	362	20	342	342	20	324	324	20	305	305	20	287	287	19	274	253	19	271	199	19
12,000	77	-	-	-	-	-	-	-	-	-	-	-	-	-	-	-	-	-	-	-	-	-
	72	-	-	-	367	340	20	361	277	20	359	213	20	356	148	20	-	-	-	-	-	-
	67	-	-	-	361	361	20	341	337	20	333	278	20	330	214	20	327	149	20	-	-	-
	62	-	-	-	360	360	20	340	340	20	319	319	20	306	278	20	303	215	19	300	150	19
	57	-	-	-	360	360	20	339	339	20	319	319	20	300	300	19	283	276	19	278	215	19

**Table 5: 25 ton standard efficiency - 85°F ambient air temperature**

CFM	EWB (°F)	95°F EDB			90°F EDB			85°F EDB			80°F EDB			75°F EDB			70°F EDB			65°F EDB		
		TMBH	SMBH	kW	TMBH	SMBH	kW	TMBH	SMBH	kW	TMBH	SMBH	kW	TMBH	SMBH	kW	TMBH	SMBH	kW	TMBH	SMBH	kW
5,000	77	321	192	22	319	164	22	318	137	22	318	109	22	-	-	-	-	-	-	-	-	-
	72	293	220	21	293	193	21	292	166	21	291	138	21	290	111	21	-	-	-	-	-	-
	67	270	248	21	268	221	21	268	194	21	267	167	21	266	139	21	265	112	21	-	-	-
	62	260	260	21	248	246	21	-	-	-	-	-	-	-	-	-	-	-	-	-	-	-
	57	259	259	21	-	-	-	-	-	-	-	-	-	-	-	-	-	-	-	-	-	-
6,750	77	344	230	22	342	192	22	341	156	22	339	118	22	-	-	-	-	-	-	-	-	-
	72	317	267	22	315	231	22	313	194	22	312	157	22	310	120	22	-	-	-	-	-	-
	67	299	299	21	291	268	21	289	232	21	287	195	21	286	158	21	285	121	21	-	-	-
	62	298	298	21	283	283	21	268	266	21	264	231	21	262	195	21	261	158	21	259	121	21
	57	297	297	21	282	282	21	267	267	21	252	252	21	-	-	-	-	-	-	-	-	-
8,500	77	-	-	-	-	-	-	-	-	-	-	-	-	-	-	-	-	-	-	-	-	-
	72	334	311	22	330	266	22	327	220	22	326	174	22	324	127	22	-	-	-	-	-	-
	67	327	327	22	310	309	22	304	267	22	300	221	21	299	176	21	297	129	21	-	-	-
	62	326	326	22	309	309	22	292	292	21	279	266	21	274	221	21	273	175	21	271	129	21
	57	325	325	22	308	308	22	291	291	21	275	275	21	259	259	21	250	220	21	249	175	21
10,250	77	-	-	-	-	-	-	-	-	-	-	-	-	-	-	-	-	-	-	-	-	-
	72	350	349	22	341	300	22	337	245	22	335	190	22	332	134	22	-	-	-	-	-	-
	67	350	350	22	331	331	22	315	300	22	310	246	22	308	192	22	306	136	22	-	-	-
	62	349	349	22	330	330	22	311	311	22	293	293	21	284	246	21	282	192	21	279	136	21
	57	348	348	22	329	329	22	310	310	22	292	292	21	274	274	21	260	245	21	257	191	21
12,000	77	-	-	-	-	-	-	-	-	-	-	-	-	-	-	-	-	-	-	-	-	-
	72	-	-	-	350	332	22	344	270	22	341	205	22	338	140	22	-	-	-	-	-	-
	67	-	-	-	346	346	22	326	326	22	317	271	22	314	207	22	312	142	22	-	-	-
	62	-	-	-	346	346	22	325	325	22	306	306	22	292	270	21	288	207	21	285	143	21
	57	-	-	-	345	345	22	325	325	22	305	305	22	287	287	21	269	267	21	263	207	21

**Table 6: 25 ton standard efficiency - 95°F ambient air temperature**

CFM	EWB (°F)	95°F EDB			90°F EDB			85°F EDB			80°F EDB			75°F EDB			70°F EDB			65°F EDB		
		TMBH	SMBH	kW	TMBH	SMBH	kW	TMBH	SMBH	kW	TMBH	SMBH	kW	TMBH	SMBH	kW	TMBH	SMBH	kW	TMBH	SMBH	kW
5,000	77	305	185	24	304	157	24	303	130	24	302	102	24	-	-	-	-	-	-	-	-	-
	72	280	214	24	280	187	24	278	159	24	278	132	24	277	104	24	-	-	-	-	-	-
	67	259	242	23	257	215	23	256	188	23	255	161	23	254	134	23	254	107	23	-	-	-
	62	251	251	23	238	238	23	233	214	23	232	187	23	231	160	23	230	132	23	229	105	23
	57	249	249	23	236	236	23	-	-	-	-	-	-	-	-	-	-	-	-	-	-	-
6,750	77	327	222	24	325	185	24	324	148	24	322	111	24	-	-	-	-	-	-	-	-	-
	72	302	260	24	300	224	24	298	187	24	297	150	24	295	113	24	-	-	-	-	-	-
	67	288	288	24	279	261	24	276	226	24	274	189	23	273	152	23	271	115	23	-	-	-
	62	287	287	24	272	272	23	257	257	23	251	224	23	249	187	23	248	151	23	246	114	23
	57	285	285	24	270	270	23	255	255	23	241	241	23	228	222	23	225	186	23	224	149	23
8,500	77	-	-	-	-	-	-	-	-	-	-	-	-	-	-	-	-	-	-	-	-	-
	72	319	304	24	314	259	24	311	213	24	310	167	24	307	121	24	-	-	-	-	-	-
	67	315	315	24	298	298	24	289	260	24	286	215	24	285	169	24	283	123	24	-	-	-
	62	313	313	24	297	297	24	280	280	24	265	258	23	260	214	23	259	168	23	257	122	23
	57	312	312	24	295	295	24	278	278	24	262	262	23	246	246	23	237	212	23	235	167	23
10,250	77	-	-	-	-	-	-	-	-	-	-	-	-	-	-	-	-	-	-	-	-	-
	72	-	-	-	324	292	24	320	238	24	318	183	24	315	127	24	-	-	-	-	-	-
	67	-	-	-	317	317	24	300	292	24	295	240	24	293	185	24	290	129	24	-	-	-
	62	-	-	-	316	316	24	297	297	24	279	279	24	269	239	23	267	184	23	264	129	23
	57	-	-	-	314	314	24	296	296	24	278	278	24	261	261	23	246	236	23	242	183	23
12,000	77	-	-	-	-	-	-	-	-	-	-	-	-	-	-	-	-	-	-	-	-	-
	72	-	-	-	-	-	-	327	263	24	323	198	24	320	133	24	-	-	-	-	-	-
	67	-	-	-	-	-	-	313	313	24	302	264	24	298	200	24	295	135	24	-	-	-
	62	-	-	-	-	-	-	311	311	24	292	292	24	277	262	24	272	200	23	269	135	23
	57	-	-	-	-	-	-	310	310	24	291	291	24	273	273	23	255	255	23	248	198	23

**Table 7: 25 ton standard efficiency - 105°F ambient air temperature**

CFM	EWB (°F)	95°F EDB			90°F EDB			85°F EDB			80°F EDB			75°F EDB			70°F EDB			65°F EDB		
		TMBH	SMBH	kW	TMBH	SMBH	kW	TMBH	SMBH	kW	TMBH	SMBH	kW	TMBH	SMBH	kW	TMBH	SMBH	kW	TMBH	SMBH	kW
5,000	77	289	177	26	287	150	26	286	122	26	285	94	26	-	-	-	-	-	-	-	-	-
	72	264	205	26	263	178	26	262	151	26	261	123	26	260	95	26	-	-	-	-	-	-
	67	244	233	26	241	206	26	241	179	26	239	152	26	238	125	26	237	97	26	-	-	-
	62	238	238	26	226	226	26	219	205	26	217	178	26	216	151	26	215	123	25	214	96	25
	57	237	237	26	225	225	26	-	-	-	-	-	-	-	-	-	-	-	-	-	-	-
6,750	77	-	-	-	-	-	-	-	-	-	-	-	-	-	-	-	-	-	-	-	-	-
	72	285	251	26	282	215	26	280	178	26	279	141	26	277	104	26	-	-	-	-	-	-
	67	274	274	26	262	252	26	259	216	26	257	180	26	256	143	26	254	106	26	-	-	-
	62	273	273	26	258	258	26	243	243	26	235	215	26	233	178	26	232	142	26	230	105	26
	57	272	272	26	257	257	26	243	243	26	228	228	26	215	213	25	211	177	25	209	141	25
8,500	77	-	-	-	-	-	-	-	-	-	-	-	-	-	-	-	-	-	-	-	-	-
	72	301	294	27	294	250	27	292	204	27	290	158	26	288	111	26	-	-	-	-	-	-
	67	300	300	27	283	283	26	271	251	26	268	205	26	266	160	26	264	113	26	-	-	-
	62	298	298	27	282	282	26	265	265	26	249	247	26	244	204	26	242	159	26	240	112	26
	57	297	297	27	281	281	26	264	264	26	248	248	26	232	232	26	222	203	26	219	158	26
10,250	77	-	-	-	-	-	-	-	-	-	-	-	-	-	-	-	-	-	-	-	-	-
	72	-	-	-	-	-	-	300	229	27	297	174	27	295	118	27	-	-	-	-	-	-
	67	-	-	-	300	300	27	283	281	26	276	230	26	273	175	26	271	120	26	-	-	-
	62	-	-	-	299	299	27	281	281	26	264	264	26	252	229	26	249	174	26	246	119	26
	57	-	-	-	298	298	27	280	280	26	263	263	26	246	246	26	231	227	26	226	174	26
12,000	77	-	-	-	-	-	-	-	-	-	-	-	-	-	-	-	-	-	-	-	-	-
	72	-	-	-	-	-	-	-	-	-	303	189	27	300	124	27	-	-	-	-	-	-
	67	-	-	-	-	-	-	296	296	27	283	254	26	279	191	26	276	126	26	-	-	-
	62	-	-	-	-	-	-	294	294	27	276	276	26	260	252	26	254	190	26	251	125	26
	57	-	-	-	-	-	-	294	294	27	275	275	26	258	258	26	240	240	26	231	189	26

**Table 8: 25 ton standard efficiency - 115°F ambient air temperature**

CFM	EWB (°F)	95°F EDB			90°F EDB			85°F EDB			80°F EDB			75°F EDB			70°F EDB			65°F EDB		
		TMBH	SMBH	kW	TMBH	SMBH	kW	TMBH	SMBH	kW	TMBH	SMBH	kW	TMBH	SMBH	kW	TMBH	SMBH	kW	TMBH	SMBH	kW
5,000	77	270	169	29	269	142	29	268	114	29	267	86	29	-	-	-	-	-	-	-	-	-
	72	247	197	29	246	169	29	245	142	29	244	114	29	242	87	29	-	-	-	-	-	-
	67	228	223	29	224	196	29	223	169	29	222	142	29	221	115	29	219	87	29	-	-	-
	62	225	225	29	213	213	29	204	196	28	202	169	28	200	141	28	199	114	28	198	86	28
	57	225	225	29	213	213	29	201	201	28	-	-	-	-	-	-	-	-	-	-	-	-
6,750	77	-	-	-	-	-	-	-	-	-	-	-	-	-	-	-	-	-	-	-	-	-
	72	266	242	29	263	206	29	261	169	29	260	132	29	258	95	29	-	-	-	-	-	-
	67	258	258	29	245	241	29	240	206	29	238	169	29	236	133	29	234	96	29	-	-	-
	62	258	258	29	243	243	29	229	229	29	219	205	29	216	169	29	214	132	29	213	95	29
	57	257	257	29	243	243	29	229	229	29	215	215	29	201	201	28	195	168	28	194	132	28
8,500	77	-	-	-	-	-	-	-	-	-	-	-	-	-	-	-	-	-	-	-	-	-
	72	-	-	-	275	240	29	272	195	29	270	149	29	267	102	29	-	-	-	-	-	-
	67	-	-	-	265	265	29	252	240	29	248	195	29	246	149	29	243	103	29	-	-	-
	62	-	-	-	265	265	29	249	249	29	233	233	29	226	195	29	223	149	29	221	103	29
	57	-	-	-	265	265	29	248	248	29	233	233	29	218	218	29	206	194	28	203	148	28
10,250	77	-	-	-	-	-	-	-	-	-	-	-	-	-	-	-	-	-	-	-	-	-
	72	-	-	-	-	-	-	-	-	-	277	165	29	273	109	29	-	-	-	-	-	-
	67	-	-	-	-	-	-	265	265	29	256	220	29	252	165	29	250	109	29	-	-	-
	62	-	-	-	-	-	-	264	264	29	247	247	29	234	219	29	230	165	29	227	109	29
	57	-	-	-	-	-	-	264	264	29	247	247	29	231	231	29	215	215	29	208	164	29
12,000	77	-	-	-	-	-	-	-	-	-	-	-	-	-	-	-	-	-	-	-	-	-
	72	-	-	-	-	-	-	-	-	-	-	-	-	-	-	-	-	-	-	-	-	-
	67	-	-	-	-	-	-	277	277	29	262	243	29	257	180	29	254	115	29	-	-	-
	62	-	-	-	-	-	-	277	277	29	259	259	29	242	240	29	234	180	29	231	116	29
	57	-	-	-	-	-	-	276	276	29	258	258	29	241	241	29	224	224	29	213	180	29

**Table 9: 25 ton standard efficiency - 125°F ambient air temperature**

CFM	EWB (°F)	95°F EDB			90°F EDB			85°F EDB			80°F EDB			75°F EDB			70°F EDB			65°F EDB		
		TMBH	SMBH	kW	TMBH	SMBH	kW	TMBH	SMBH	kW	TMBH	SMBH	kW	TMBH	SMBH	kW	TMBH	SMBH	kW	TMBH	SMBH	kW
5,000	77	-	-	-	-	-	-	-	-	-	-	-	-	-	-	-	-	-	-	-	-	-
	72	229	188	32	227	160	32	226	133	32	225	106	32	223	78	32	-	-	-	-	-	-
	67	212	212	32	207	188	32	205	160	32	204	133	32	203	106	32	202	78	32	-	-	-
	62	212	212	32	200	200	32	189	186	32	185	160	32	184	132	32	183	105	32	181	77	32
	57	211	211	32	199	199	32	187	187	32	176	176	32	-	-	-	-	-	-	-	-	-
6,750	77	-	-	-	-	-	-	-	-	-	-	-	-	-	-	-	-	-	-	-	-	-
	72	247	233	33	242	197	33	241	160	33	239	123	33	237	86	33	-	-	-	-	-	-
	67	242	242	33	228	228	32	221	196	32	219	160	32	217	123	32	215	86	32	-	-	-
	62	242	242	33	228	228	32	214	214	32	201	195	32	198	160	32	196	123	32	194	86	32
	57	241	241	33	227	227	32	213	213	32	199	199	32	186	186	32	178	159	32	177	122	32
8,500	77	-	-	-	-	-	-	-	-	-	-	-	-	-	-	-	-	-	-	-	-	-
	72	-	-	-	-	-	-	-	-	-	248	140	33	245	93	33	-	-	-	-	-	-
	67	-	-	-	248	248	33	233	229	32	228	186	32	225	140	32	223	93	32	-	-	-
	62	-	-	-	247	247	33	232	232	32	217	217	32	207	185	32	204	139	32	202	93	32
	57	-	-	-	247	247	33	231	231	32	216	216	32	202	202	32	188	183	32	184	139	32
10,250	77	-	-	-	-	-	-	-	-	-	-	-	-	-	-	-	-	-	-	-	-	-
	72	-	-	-	-	-	-	-	-	-	-	-	-	-	-	-	-	-	-	-	-	-
	67	-	-	-	-	-	-	246	246	33	235	210	32	231	155	32	228	99	32	-	-	-
	62	-	-	-	-	-	-	246	246	33	230	230	32	215	208	32	210	155	32	207	99	32
	57	-	-	-	-	-	-	246	246	33	229	229	32	214	214	32	198	198	32	190	154	32
12,000	77	-	-	-	-	-	-	-	-	-	-	-	-	-	-	-	-	-	-	-	-	-
	72	-	-	-	-	-	-	-	-	-	-	-	-	-	-	-	-	-	-	-	-	-
	67	-	-	-	-	-	-	-	-	-	241	232	33	236	171	33	232	105	32	-	-	-
	62	-	-	-	-	-	-	-	-	-	240	240	33	222	222	32	214	170	32	210	105	32
	57	-	-	-	-	-	-	-	-	-	239	239	33	222	222	32	206	206	32	194	169	32

**Notes:**

Rated performance is at sea level. Cooling capacities are gross cooling capacities.  
 CFM = airflow, EWB = entering wet bulb air, EDB = entering dry bulb air, TMBH = total cooling capacity (MBH)  
 SMBH = sensible cooling capacity (MBH), kW = total input

## Cooling performance data 25 ton high efficiency

**Table 10: 25 ton high efficiency - 75°F ambient air temperature**

CFM	EWB (°F)	95°F EDB			90°F EDB			85°F EDB			80°F EDB			75°F EDB			70°F EDB			65°F EDB		
		TMBH	SMBH	kW	TMBH	SMBH	kW	TMBH	SMBH	kW	TMBH	SMBH	kW	TMBH	SMBH	kW	TMBH	SMBH	kW	TMBH	SMBH	kW
5,000	77	351	211	18	351	184	18	350	157	18	350	129	18	-	-	-	-	-	-	-	-	-
	72	321	239	18	321	212	18	321	185	18	320	158	18	320	131	18	-	-	-	-	-	-
	67	294	266	18	293	239	18	292	212	18	292	184	18	290	156	18	290	129	18	-	-	-
	62	279	279	18	-	-	-	-	-	-	-	-	-	-	-	-	-	-	-	-	-	-
	57	279	279	18	-	-	-	-	-	-	-	-	-	-	-	-	-	-	-	-	-	-
6,750	77	-	-	-	-	-	-	-	-	-	-	-	-	-	-	-	-	-	-	-	-	-
	72	345	286	18	344	249	18	343	213	18	343	176	18	342	139	18	-	-	-	-	-	-
	67	322	321	18	317	286	18	315	249	18	314	212	18	312	175	18	311	138	18	-	-	-
	62	321	321	18	304	304	18	288	282	18	284	246	18	283	209	18	282	172	18	281	134	18
	57	321	321	18	303	303	18	285	285	18	-	-	-	-	-	-	-	-	-	-	-	-
8,500	77	-	-	-	-	-	-	-	-	-	-	-	-	-	-	-	-	-	-	-	-	-
	72	-	-	-	360	285	18	358	239	18	358	193	18	356	146	18	-	-	-	-	-	-
	67	352	352	18	336	330	18	330	285	18	327	238	18	326	192	18	324	145	18	-	-	-
	62	352	352	18	333	333	18	314	314	18	300	282	18	296	235	18	295	189	18	293	142	18
	57	351	351	18	333	333	18	313	313	18	294	294	18	275	275	18	268	232	18	266	185	18
10,250	77	-	-	-	-	-	-	-	-	-	-	-	-	-	-	-	-	-	-	-	-	-
	72	-	-	-	-	-	-	-	-	-	-	-	-	-	-	-	-	-	-	-	-	-
	67	-	-	-	357	357	18	342	320	18	337	264	18	335	208	18	333	151	18	-	-	-
	62	-	-	-	356	356	18	335	335	18	314	313	18	306	261	18	304	205	18	302	148	18
	57	-	-	-	356	356	18	335	335	18	314	314	18	293	293	18	277	258	18	275	202	18
12,000	77	-	-	-	-	-	-	-	-	-	-	-	-	-	-	-	-	-	-	-	-	-
	72	-	-	-	-	-	-	-	-	-	-	-	-	-	-	-	-	-	-	-	-	-
	67	-	-	-	-	-	-	353	350	18	345	289	18	342	223	18	339	157	18	-	-	-
	62	-	-	-	-	-	-	352	352	18	329	329	18	314	286	18	310	221	18	308	155	18
	57	-	-	-	-	-	-	352	352	18	329	329	18	307	307	18	287	282	18	281	218	18

**Table 11: 25 ton high efficiency - 85°F ambient air temperature**

CFM	EWB (°F)	95°F EDB			90°F EDB			85°F EDB			80°F EDB			75°F EDB			70°F EDB			65°F EDB		
		TMBH	SMBH	kW	TMBH	SMBH	kW	TMBH	SMBH	kW	TMBH	SMBH	kW	TMBH	SMBH	kW	TMBH	SMBH	kW	TMBH	SMBH	kW
5,000	77	337	206	20	337	179	20	337	151	20	336	124	20	-	-	-	-	-	-	-	-	-
	72	307	232	20	306	204	20	305	177	20	304	149	20	304	121	20	-	-	-	-	-	-
	67	277	255	20	276	228	20	275	200	20	274	173	20	273	145	20	273	117	20	-	-	-
	62	266	266	20	-	-	-	-	-	-	-	-	-	-	-	-	-	-	-	-	-	-
	57	265	265	20	-	-	-	-	-	-	-	-	-	-	-	-	-	-	-	-	-	-
6,750	77	-	-	-	-	-	-	-	-	-	-	-	-	-	-	-	-	-	-	-	-	-
	72	329	278	20	327	241	20	326	203	20	325	166	20	323	129	20	-	-	-	-	-	-
	67	307	307	20	298	275	20	296	238	20	294	200	20	293	163	20	292	125	20	-	-	-
	62	306	306	20	289	289	20	272	270	20	267	234	20	265	197	20	264	160	20	263	122	20
	57	305	305	20	288	288	20	271	271	20	254	254	20	-	-	-	-	-	-	-	-	-
8,500	77	-	-	-	-	-	-	-	-	-	-	-	-	-	-	-	-	-	-	-	-	-
	72	-	-	-	-	-	-	-	-	-	-	-	-	335	135	20	-	-	-	-	-	-
	67	-	-	-	318	316	20	310	273	20	307	226	20	306	180	20	304	132	20	-	-	-
	62	-	-	-	317	317	20	297	297	20	282	270	20	277	223	20	276	177	20	274	130	20
	57	-	-	-	316	316	20	297	297	20	278	278	20	259	259	20	250	220	20	248	174	20
10,250	77	-	-	-	-	-	-	-	-	-	-	-	-	-	-	-	-	-	-	-	-	-
	72	-	-	-	-	-	-	-	-	-	-	-	-	-	-	-	-	-	-	-	-	-
	67	-	-	-	-	-	-	321	308	20	316	252	20	314	195	20	311	138	20	-	-	-
	62	-	-	-	-	-	-	317	317	20	297	297	20	286	249	20	284	193	20	282	136	20
	57	-	-	-	-	-	-	317	317	20	296	296	20	276	276	20	260	246	20	256	190	20
12,000	77	-	-	-	-	-	-	-	-	-	-	-	-	-	-	-	-	-	-	-	-	-
	72	-	-	-	-	-	-	-	-	-	-	-	-	-	-	-	-	-	-	-	-	-
	67	-	-	-	-	-	-	-	-	-	323	277	20	319	211	20	316	144	20	-	-	-
	62	-	-	-	-	-	-	-	-	-	311	311	20	294	274	20	290	208	20	287	142	20
	57	-	-	-	-	-	-	-	-	-	311	311	20	289	289	20	269	268	20	262	206	20

**Table 12: 25 ton high efficiency - 95°F ambient air temperature**

CFM	EWB (°F)	95°F EDB			90°F EDB			85°F EDB			80°F EDB			75°F EDB			70°F EDB			65°F EDB		
		TMBH	SMBH	kW	TMBH	SMBH	kW	TMBH	SMBH	kW	TMBH	SMBH	kW	TMBH	SMBH	kW	TMBH	SMBH	kW	TMBH	SMBH	kW
5,000	77	-	-	-	-	-	-	-	-	-	-	-	-	-	-	-	-	-	-	-	-	-
	72	288	220	22	287	193	22	287	165	22	286	137	22	285	109	22	-	-	-	-	-	-
	67	260	244	22	258	216	22	257	188	22	257	161	22	255	133	22	255	105	22	-	-	-
	62	252	252	22	237	237	22	231	212	22	230	185	22	229	157	22	228	130	22	228	102	22
	57	251	251	22	237	237	22	-	-	-	-	-	-	-	-	-	-	-	-	-	-	-
6,750	77	-	-	-	-	-	-	-	-	-	-	-	-	-	-	-	-	-	-	-	-	-
	72	309	266	22	307	229	22	305	191	22	304	154	22	302	116	22	-	-	-	-	-	-
	67	290	290	22	279	262	22	276	225	22	274	188	22	274	151	22	272	113	22	-	-	-
	62	290	290	22	273	273	22	256	256	22	249	222	22	247	185	22	246	148	22	244	110	22
	57	290	290	22	272	272	22	256	256	22	239	239	22	-	-	-	-	-	-	-	-	-
8,500	77	-	-	-	-	-	-	-	-	-	-	-	-	-	-	-	-	-	-	-	-	-
	72	-	-	-	-	-	-	-	-	-	-	-	-	-	-	-	-	-	-	-	-	-
	67	-	-	-	300	300	22	289	261	22	286	214	22	285	167	22	282	120	22	-	-	-
	62	-	-	-	299	299	22	280	280	22	263	257	22	258	211	22	257	164	22	254	117	22
	57	-	-	-	299	299	22	280	280	22	262	262	22	243	243	22	232	208	22	230	162	22
10,250	77	-	-	-	-	-	-	-	-	-	-	-	-	-	-	-	-	-	-	-	-	-
	72	-	-	-	-	-	-	-	-	-	-	-	-	-	-	-	-	-	-	-	-	-
	67	-	-	-	-	-	300	293	22	294	239	22	292	182	22	289	126	22	-	-	-	-
	62	-	-	-	-	-	299	299	22	278	278	22	267	237	22	263	180	22	261	124	22	22
	57	-	-	-	-	-	299	299	22	278	278	22	259	259	22	242	234	22	237	178	22	22
12,000	77	-	-	-	-	-	-	-	-	-	-	-	-	-	-	-	-	-	-	-	-	-
	72	-	-	-	-	-	-	-	-	-	-	-	-	-	-	-	-	-	-	-	-	-
	67	-	-	-	-	-	-	-	-	301	264	22	297	198	22	294	131	22	-	-	-	-
	62	-	-	-	-	-	-	-	-	292	292	22	274	261	22	269	196	22	266	129	22	22
	57	-	-	-	-	-	-	-	-	292	292	22	272	272	22	251	251	22	242	193	22	22

**Table 13: 25 ton high efficiency - 105°F ambient air temperature**

CFM	EWB (°F)	95°F EDB			90°F EDB			85°F EDB			80°F EDB			75°F EDB			70°F EDB			65°F EDB		
		TMBH	SMBH	kW	TMBH	SMBH	kW	TMBH	SMBH	kW	TMBH	SMBH	kW	TMBH	SMBH	kW	TMBH	SMBH	kW	TMBH	SMBH	kW
5,000	77	-	-	-	-	-	-	-	-	-	-	-	-	-	-	-	-	-	-	-	-	-
	72	269	209	25	268	181	25	267	153	25	266	126	25	265	98	25	-	-	-	-	-	-
	67	242	232	24	240	205	24	239	177	24	238	149	24	238	122	24	236	94	24	-	-	-
	62	237	237	24	223	223	24	215	201	24	213	173	24	212	146	24	211	118	24	211	90	24
	57	237	237	24	222	222	24	-	-	-	-	-	-	-	-	-	-	-	-	-	-	-
6,750	77	-	-	-	-	-	-	-	-	-	-	-	-	-	-	-	-	-	-	-	-	-
	72	-	-	-	-	-	284	180	25	283	142	25	281	105	25	-	-	-	-	-	-	-
	67	274	274	25	260	251	25	257	214	25	255	176	25	254	139	25	252	101	25	-	-	-
	62	274	274	25	257	257	25	240	240	24	231	211	24	228	173	24	227	136	24	226	99	24
	57	273	273	25	256	256	25	240	240	24	223	223	24	208	206	24	203	170	24	202	133	24
8,500	77	-	-	-	-	-	-	-	-	-	-	-	-	-	-	-	-	-	-	-	-	-
	72	-	-	-	-	-	-	-	-	-	-	-	-	-	-	-	-	-	-	-	-	-
	67	-	-	-	-	-	269	249	25	265	202	25	263	155	25	261	108	25	-	-	-	-
	62	-	-	-	-	-	263	263	25	245	244	24	239	199	24	237	152	24	235	105	24	24
	57	-	-	-	-	-	263	263	25	244	244	24	226	226	24	214	196	24	212	149	24	24
10,250	77	-	-	-	-	-	-	-	-	-	-	-	-	-	-	-	-	-	-	-	-	-
	72	-	-	-	-	-	-	-	-	-	-	-	-	-	-	-	-	-	-	-	-	-
	67	-	-	-	-	-	-	-	-	273	227	25	270	170	25	267	113	25	-	-	-	-
	62	-	-	-	-	-	-	-	-	261	261	25	247	225	25	243	168	24	240	111	24	24
	57	-	-	-	-	-	-	-	-	260	260	25	241	241	24	223	220	24	218	165	24	24
12,000	77	-	-	-	-	-	-	-	-	-	-	-	-	-	-	-	-	-	-	-	-	-
	72	-	-	-	-	-	-	-	-	-	-	-	-	-	-	-	-	-	-	-	-	-
	67	-	-	-	-	-	-	-	-	280	252	25	275	186	25	271	119	25	-	-	-	-
	62	-	-	-	-	-	-	-	-	273	273	25	254	248	25	248	184	25	245	117	25	25
	57	-	-	-	-	-	-	-	-	273	273	25	253	253	25	233	233	24	223	181	24	24

**Table 14: 25 ton high efficiency - 115°F ambient air temperature**

CFM	EWB (°F)	95°F EDB			90°F EDB			85°F EDB			80°F EDB			75°F EDB			70°F EDB			65°F EDB		
		TMBH	SMBH	kW	TMBH	SMBH	kW	TMBH	SMBH	kW	TMBH	SMBH	kW	TMBH	SMBH	kW	TMBH	SMBH	kW	TMBH	SMBH	kW
5,000	77	-	-	-	-	-	-	-	-	-	-	-	-	-	-	-	-	-	-	-	-	-
	72	248	197	27	248	169	27	246	141	27	246	114	27	244	86	27	-	-	-	-	-	-
	67	225	220	27	221	193	27	220	165	27	219	138	27	219	110	27	217	82	27	-	-	-
	62	222	222	27	208	208	27	197	189	27	195	161	27	194	134	27	193	106	27	192	78	27
	57	221	221	27	207	207	27	193	193	27	-	-	-	-	-	-	-	-	-	-	-	-
6,750	77	-	-	-	-	-	-	-	-	-	-	-	-	-	-	-	-	-	-	-	-	-
	72	-	-	-	-	-	-	-	-	-	-	-	-	-	-	-	-	-	-	-	-	-
	67	-	-	-	241	237	27	236	202	27	234	164	27	233	127	27	231	89	27	-	-	-
	62	-	-	-	239	239	27	223	223	27	211	198	27	208	161	27	207	124	27	206	86	27
	57	-	-	-	239	239	27	222	222	27	206	206	27	191	191	27	184	157	27	183	120	27
8,500	77	-	-	-	-	-	-	-	-	-	-	-	-	-	-	-	-	-	-	-	-	-
	72	-	-	-	-	-	-	-	-	-	-	-	-	-	-	-	-	-	-	-	-	-
	67	-	-	-	-	-	-	248	236	27	244	190	27	242	143	27	239	95	27	-	-	-
	62	-	-	-	-	-	-	244	244	27	226	226	27	218	187	27	216	140	27	213	93	27
	57	-	-	-	-	-	-	244	244	27	226	226	27	209	209	27	195	183	27	191	136	27
10,250	77	-	-	-	-	-	-	-	-	-	-	-	-	-	-	-	-	-	-	-	-	-
	72	-	-	-	-	-	-	-	-	-	-	-	-	-	-	-	-	-	-	-	-	-
	67	-	-	-	-	-	-	-	-	251	215	27	248	158	27	244	101	27	-	-	-	-
	62	-	-	-	-	-	-	-	-	241	241	27	226	212	27	222	156	27	219	99	27	27
	57	-	-	-	-	-	-	-	-	241	241	27	222	222	27	204	204	27	197	152	27	27
12,000	77	-	-	-	-	-	-	-	-	-	-	-	-	-	-	-	-	-	-	-	-	-
	72	-	-	-	-	-	-	-	-	-	-	-	-	-	-	-	-	-	-	-	-	-
	67	-	-	-	-	-	-	-	-	-	-	-	252	174	27	248	107	27	-	-	-	-
	62	-	-	-	-	-	-	-	-	-	-	-	233	232	27	226	171	27	222	104	27	27
	57	-	-	-	-	-	-	-	-	-	-	-	233	233	27	213	213	27	202	168	27	27

**Table 15: 25 ton high efficiency - 125°F ambient air temperature**

CFM	EWB (°F)	95°F EDB			90°F EDB			85°F EDB			80°F EDB			75°F EDB			70°F EDB			65°F EDB		
		TMBH	SMBH	kW	TMBH	SMBH	kW	TMBH	SMBH	kW	TMBH	SMBH	kW	TMBH	SMBH	kW	TMBH	SMBH	kW	TMBH	SMBH	kW
5,000	77	-	-	-	-	-	-	-	-	-	-	-	-	-	-	-	-	-	-	-	-	-
	72	226	184	30	225	156	30	224	129	30	223	101	30	221	73	30	-	-	-	-	-	-
	67	205	205	30	200	180	30	199	153	30	198	125	30	197	97	30	196	69	30	-	-	-
	62	205	205	30	191	191	30	178	175	30	175	148	30	173	121	30	173	93	30	172	65	30
	57	204	204	30	190	190	30	176	176	30	162	162	30	-	-	-	-	-	-	-	-	-
6,750	77	-	-	-	-	-	-	-	-	-	-	-	-	-	-	-	-	-	-	-	-	-
	72	-	-	-	-	-	-	-	-	-	-	-	-	-	-	-	-	-	-	-	-	-
	67	-	-	-	221	221	30	213	188	30	211	151	30	209	114	30	208	76	30	-	-	-
	62	-	-	-	220	220	30	204	204	30	190	184	30	187	148	30	185	110	30	183	73	30
	57	-	-	-	220	220	30	204	204	30	188	188	30	172	172	30	164	144	30	162	106	30
8,500	77	-	-	-	-	-	-	-	-	-	-	-	-	-	-	-	-	-	-	-	-	-
	72	-	-	-	-	-	-	-	-	-	-	-	-	-	-	-	-	-	-	-	-	-
	67	-	-	-	-	-	-	-	-	220	177	30	217	129	30	214	82	30	-	-	-	-
	62	-	-	-	-	-	-	-	-	206	206	30	195	173	30	193	126	30	190	79	30	30
	57	-	-	-	-	-	-	-	-	206	206	30	189	189	30	173	169	30	169	123	30	30
10,250	77	-	-	-	-	-	-	-	-	-	-	-	-	-	-	-	-	-	-	-	-	-
	72	-	-	-	-	-	-	-	-	-	-	-	-	-	-	-	-	-	-	-	-	-
	67	-	-	-	-	-	-	-	-	-	-	-	222	145	31	219	88	30	-	-	-	-
	62	-	-	-	-	-	-	-	-	220	220	30	203	197	30	198	142	30	194	85	30	30
	57	-	-	-	-	-	-	-	-	220	220	30	201	201	30	184	184	30	175	139	30	30
12,000	77	-	-	-	-	-	-	-	-	-	-	-	-	-	-	-	-	-	-	-	-	-
	72	-	-	-	-	-	-	-	-	-	-	-	-	-	-	-	-	-	-	-	-	-
	67	-	-	-	-	-	-	-	-	-	-	-	-	-	-	222	93	31	-	-	-	-
	62	-	-	-	-	-	-	-	-	-	-	-	-	-	-	211	211	30	201	157	30	197
	57	-	-	-	-	-	-	-	-	-	-	-	-	-	-	211	211	30	192	192	30	178

**Notes:**  
 Rated performance is at sea level. Cooling capacities are gross cooling capacities.  
 CFM = airflow, EWB = entering wet bulb air, EDB = entering dry bulb air, TMBH = total cooling capacity (MBH)  
 SMBH = sensible cooling capacity (MBH), kW = total input

## Cooling performance data 25 ton high capacity

**Table 16: 25 ton high capacity - 75°F ambient air temperature**

CFM	EWB (°F)	95°F EDB			90°F EDB			85°F EDB			80°F EDB			75°F EDB			70°F EDB			65°F EDB		
		TMBH	SMBH	kW	TMBH	SMBH	kW	TMBH	SMBH	kW	TMBH	SMBH	kW	TMBH	SMBH	kW	TMBH	SMBH	kW	TMBH	SMBH	kW
5,000	77	372	220	21	372	193	21	371	165	21	371	138	21	-	-	-	-	-	-	-	-	-
	72	340	248	21	340	221	21	340	194	21	339	166	21	339	139	21	-	-	-	-	-	-
	67	310	275	20	310	247	20	309	220	20	309	193	20	308	165	20	307	137	20	-	-	-
	62	-	-	-	-	-	-	-	-	-	-	-	-	-	-	-	-	-	-	-	-	-
	57	-	-	-	-	-	-	-	-	-	-	-	-	-	-	-	-	-	-	-	-	-
6,750	77	-	-	-	399	220	22	399	183	21	398	146	21	-	-	-	-	-	-	-	-	-
	72	367	295	21	367	258	21	366	222	21	366	185	21	365	148	21	-	-	-	-	-	-
	67	340	332	21	336	295	21	335	258	21	334	221	21	333	184	21	332	147	21	-	-	-
	62	337	337	21	318	318	21	305	292	20	303	255	20	302	218	20	300	181	20	295	142	20
	57	336	336	21	318	318	21	300	300	20	-	-	-	-	-	-	-	-	-	-	-	-
8,500	77	-	-	-	-	-	-	-	-	-	-	-	-	-	-	-	-	-	-	-	-	-
	72	386	341	21	384	295	21	382	248	21	382	202	21	381	155	21	-	-	-	-	-	-
	67	371	371	21	356	341	21	352	295	21	349	248	21	348	201	21	346	154	21	-	-	-
	62	370	370	21	351	351	21	330	330	21	319	292	21	317	245	21	315	198	21	313	151	21
	57	369	369	21	350	350	21	330	330	21	310	310	21	291	288	20	286	241	20	284	195	20
10,250	77	-	-	-	-	-	-	-	-	-	-	-	-	-	-	-	-	-	-	-	-	-
	72	-	-	-	397	330	21	394	274	21	393	218	21	391	162	21	-	-	-	-	-	-
	67	397	397	21	377	377	21	365	330	21	361	273	21	359	217	21	357	161	21	-	-	-
	62	397	397	21	376	376	21	354	354	21	334	327	21	327	271	21	326	215	21	323	158	21
	57	396	396	21	375	375	21	353	353	21	331	331	21	310	310	21	297	268	20	294	212	20
12,000	77	-	-	-	-	-	-	-	-	-	-	-	-	-	-	-	-	-	-	-	-	-
	72	-	-	-	-	-	-	-	-	-	401	234	22	398	167	21	-	-	-	-	-	-
	67	-	-	-	397	397	21	376	364	21	369	299	21	367	233	21	364	167	21	-	-	-
	62	-	-	-	396	396	21	373	373	21	349	349	21	336	296	21	333	231	21	330	164	21
	57	-	-	-	395	395	21	372	372	21	349	349	21	325	325	21	306	293	20	302	228	20

**Table 17: 25 ton high capacity - 85°F ambient air temperature**

CFM	EWB (°F)	95°F EDB			90°F EDB			85°F EDB			80°F EDB			75°F EDB			70°F EDB			65°F EDB		
		TMBH	SMBH	kW	TMBH	SMBH	kW	TMBH	SMBH	kW	TMBH	SMBH	kW	TMBH	SMBH	kW	TMBH	SMBH	kW	TMBH	SMBH	kW
5,000	77	358	214	23	358	187	23	357	160	23	357	132	23	-	-	-	-	-	-	-	-	-
	72	325	240	23	325	213	23	324	185	23	323	157	23	323	129	23	-	-	-	-	-	-
	67	293	263	22	292	235	22	291	208	22	291	181	22	290	153	22	289	125	22	-	-	-
	62	-	-	-	-	-	-	-	-	-	-	-	-	-	-	-	-	-	-	-	-	-
	57	-	-	-	-	-	-	-	-	-	-	-	-	-	-	-	-	-	-	-	-	-
6,750	77	-	-	-	-	-	-	-	-	-	-	-	-	-	-	-	-	-	-	-	-	-
	72	350	287	23	349	250	23	347	212	23	347	175	23	345	137	23	-	-	-	-	-	-
	67	322	320	23	317	283	23	315	246	23	314	209	23	313	171	23	311	134	23	-	-	-
	62	321	321	23	303	303	23	288	280	22	284	243	22	283	206	22	282	168	22	280	131	22
	57	320	320	23	302	302	23	285	285	22	-	-	-	-	-	-	-	-	-	-	-	-
8,500	77	-	-	-	-	-	-	-	-	-	-	-	-	-	-	-	-	-	-	-	-	-
	72	368	332	23	365	285	23	362	238	23	361	191	23	359	144	23	-	-	-	-	-	-
	67	354	354	23	336	328	23	331	282	23	328	235	23	327	188	23	325	141	23	-	-	-
	62	354	354	23	333	333	23	313	313	23	300	279	23	296	232	23	295	186	23	294	138	23
	57	353	353	23	333	333	23	313	313	23	293	293	23	274	274	22	268	229	22	266	183	22
10,250	77	-	-	-	-	-	-	-	-	-	-	-	-	-	-	-	-	-	-	-	-	-
	72	-	-	-	-	-	373	263	23	371	207	23	368	150	23	-	-	-	-	-	-	-
	67	-	-	-	358	358	23	343	317	23	338	260	23	336	204	23	334	147	23	-	-	-
	62	-	-	-	357	357	23	335	335	23	314	313	23	307	258	23	305	202	23	302	145	23
	57	-	-	-	357	357	23	335	335	23	314	314	23	293	293	23	278	255	22	275	199	22
12,000	77	-	-	-	-	-	-	-	-	-	-	-	-	-	-	-	-	-	-	-	-	-
	72	-	-	-	-	-	-	-	-	-	-	-	-	-	-	-	-	-	-	-	-	-
	67	-	-	-	-	-	354	349	23	346	285	23	343	219	23	340	153	23	-	-	-	-
	62	-	-	-	-	-	353	353	23	330	330	23	315	283	23	311	218	23	308	151	23	23
	57	-	-	-	-	-	352	352	23	329	329	23	307	307	23	287	280	23	282	215	22	22

**Table 18: 25 ton high capacity - 95°F ambient air temperature**

CFM	EWB (°F)	95°F EDB			90°F EDB			85°F EDB			80°F EDB			75°F EDB			70°F EDB			65°F EDB		
		TMBH	SMBH	kW	TMBH	SMBH	kW	TMBH	SMBH	kW	TMBH	SMBH	kW	TMBH	SMBH	kW	TMBH	SMBH	kW	TMBH	SMBH	kW
5,000	77	339	204	26	338	176	26	338	149	26	337	121	26	-	-	-	-	-	-	-	-	-
	72	305	227	25	305	200	25	304	172	25	303	144	25	302	117	25	-	-	-	-	-	-
	67	274	250	25	273	222	25	272	195	25	271	167	25	270	139	25	269	111	25	-	-	-
	62	262	262	25	-	-	-	-	-	-	-	-	-	-	-	-	-	-	-	-	-	-
	57	263	263	25	-	-	-	-	-	-	-	-	-	-	-	-	-	-	-	-	-	-
6,750	77	-	-	-	-	-	-	-	-	-	-	-	-	-	-	-	-	-	-	-	-	
	72	328	274	26	327	237	25	325	199	25	324	162	25	323	124	25	-	-	-	-	-	-
	67	303	303	25	296	269	25	293	232	25	292	194	25	291	157	25	289	120	25	-	-	-
	62	304	304	25	286	286	25	269	266	25	264	229	25	263	192	25	262	155	25	260	117	25
	57	304	304	25	286	286	25	269	269	25	252	252	25	-	-	-	-	-	-	-	-	-
8,500	77	-	-	-	-	-	-	-	-	-	-	-	-	-	-	-	-	-	-	-	-	-
	72	-	-	-	341	272	26	339	225	26	337	178	26	335	130	26	-	-	-	-	-	-
	67	335	335	26	315	313	25	308	268	25	305	220	25	303	174	25	301	126	25	-	-	-
	62	335	335	26	315	315	25	295	295	25	280	266	25	275	218	25	274	172	25	272	125	25
	57	335	335	26	315	315	25	296	296	25	276	276	25	258	258	25	249	216	25	247	170	25
10,250	77	-	-	-	-	-	-	-	-	-	-	-	-	-	-	-	-	-	-	-	-	-
	72	-	-	-	-	-	-	-	-	-	-	-	-	343	136	26	-	-	-	-	-	-
	67	-	-	-	337	337	26	319	302	25	314	246	25	312	189	25	309	132	25	-	-	-
	62	-	-	-	337	337	26	316	316	25	294	294	25	285	244	25	282	188	25	280	131	25
	57	-	-	-	338	338	26	316	316	25	295	295	25	275	275	25	259	243	25	255	186	25
12,000	77	-	-	-	-	-	-	-	-	-	-	-	-	-	-	-	-	-	-	-	-	-
	72	-	-	-	-	-	-	-	-	-	-	-	-	-	-	-	-	-	-	-	-	-
	67	-	-	-	-	-	-	331	331	26	321	271	26	318	205	25	315	138	25	-	-	-
	62	-	-	-	-	-	-	332	332	26	309	309	25	293	269	25	288	203	25	285	137	25
	57	-	-	-	-	-	-	332	332	26	310	310	25	289	289	25	268	266	25	261	202	25

**Table 19: 25 ton high capacity - 105°F ambient air temperature**

CFM	EWB (°F)	95°F EDB			90°F EDB			85°F EDB			80°F EDB			75°F EDB			70°F EDB			65°F EDB		
		TMBH	SMBH	kW	TMBH	SMBH	kW	TMBH	SMBH	kW	TMBH	SMBH	kW	TMBH	SMBH	kW	TMBH	SMBH	kW	TMBH	SMBH	kW
5,000	77	318	192	28	316	164	28	316	136	28	314	108	28	-	-	-	-	-	-	-	-	-
	72	285	216	28	285	188	28	284	160	28	283	133	28	282	104	28	-	-	-	-	-	-
	67	256	238	28	254	210	28	253	183	28	253	155	28	251	127	28	251	100	28	-	-	-
	62	248	248	27	233	233	27	-	-	-	-	-	-	226	152	27	225	125	27	224	97	27
	57	247	247	27	233	233	27	-	-	-	-	-	-	-	-	-	-	-	-	-	-	-
6,750	77	-	-	-	-	-	-	-	-	-	-	-	-	-	-	-	-	-	-	-	-	-
	72	307	261	28	305	224	28	303	187	28	302	150	28	300	112	28	-	-	-	-	-	-
	67	286	286	28	276	257	28	273	220	28	271	182	28	270	145	28	268	108	28	-	-	-
	62	287	287	28	269	269	28	252	252	28	246	217	27	243	180	27	243	143	27	241	106	27
	57	286	286	28	269	269	28	252	252	28	235	235	27	-	-	-	-	-	-	-	-	-
8,500	77	-	-	-	-	-	-	-	-	-	-	-	-	-	-	-	-	-	-	-	-	-
	72	-	-	-	-	-	-	-	-	-	313	165	28	311	118	28	-	-	-	-	-	-
	67	-	-	-	296	296	28	286	255	28	283	208	28	281	161	28	279	114	28	-	-	-
	62	-	-	-	296	296	28	277	277	28	260	253	28	255	206	28	254	160	28	251	112	28
	57	-	-	-	296	296	28	277	277	28	258	258	28	240	240	27	229	204	27	227	157	27
10,250	77	-	-	-	-	-	-	-	-	-	-	-	-	-	-	-	-	-	-	-	-	-
	72	-	-	-	-	-	-	-	-	-	-	-	-	-	-	-	-	-	-	-	-	-
	67	-	-	-	-	-	-	297	289	28	291	234	28	289	177	28	286	120	28	-	-	-
	62	-	-	-	-	-	-	296	296	28	276	276	28	264	232	28	261	175	28	258	119	28
	57	-	-	-	-	-	-	296	296	28	276	276	28	256	256	28	239	229	27	234	173	27
12,000	77	-	-	-	-	-	-	-	-	-	-	-	-	-	-	-	-	-	-	-	-	-
	72	-	-	-	-	-	-	-	-	-	-	-	-	-	-	-	-	-	-	-	-	-
	67	-	-	-	-	-	-	-	-	-	298	259	28	294	192	28	291	126	28	-	-	-
	62	-	-	-	-	-	-	-	-	-	290	290	28	272	257	28	266	191	28	263	125	28
	57	-	-	-	-	-	-	-	-	-	290	290	28	269	269	28	248	248	28	239	189	27

**Table 20: 25 ton high capacity - 115°F ambient air temperature**

CFM	EWB (°F)	95°F EDB			90°F EDB			85°F EDB			80°F EDB			75°F EDB			70°F EDB			65°F EDB		
		TMBH	SMBH	kW	TMBH	SMBH	kW	TMBH	SMBH	kW	TMBH	SMBH	kW	TMBH	SMBH	kW	TMBH	SMBH	kW	TMBH	SMBH	kW
5,000	77	-	-	-	-	-	-	-	-	-	-	-	-	-	-	-	-	-	-	-	-	-
	72	263	203	31	263	176	31	262	148	31	261	120	31	260	92	31	-	-	-	-	-	-
	67	237	227	31	235	199	31	234	172	31	233	144	31	232	116	31	231	88	31	-	-	-
	62	232	232	31	217	217	30	208	195	30	207	167	30	206	140	30	205	112	30	204	84	30
	57	231	231	31	216	216	30	-	-	-	-	-	-	-	-	-	-	-	-	-	-	-
6,750	77	-	-	-	-	-	-	-	-	-	-	-	-	-	-	-	-	-	-	-	-	-
	72	283	249	31	280	211	31	279	174	31	278	137	31	276	99	31	-	-	-	-	-	-
	67	269	269	31	255	245	31	252	208	31	250	171	31	249	134	31	247	96	31	-	-	-
	62	268	268	31	251	251	31	234	234	31	225	205	31	222	167	31	221	130	31	220	93	31
	57	268	268	31	251	251	31	234	234	31	217	217	30	201	200	30	197	163	30	196	126	30
8,500	77	-	-	-	-	-	-	-	-	-	-	-	-	-	-	-	-	-	-	-	-	-
	72	-	-	-	-	-	-	-	-	-	-	-	-	-	-	-	-	-	-	-	-	-
	67	-	-	-	277	277	31	264	243	31	260	196	31	258	149	31	256	102	31	-	-	-
	62	-	-	-	276	276	31	258	258	31	239	238	31	233	193	31	231	146	31	229	99	31
	57	-	-	-	276	276	31	257	257	31	238	238	31	220	220	31	208	190	30	205	143	30
10,250	77	-	-	-	-	-	-	-	-	-	-	-	-	-	-	-	-	-	-	-	-	-
	72	-	-	-	-	-	-	-	-	-	-	-	-	-	-	-	-	-	-	-	-	-
	67	-	-	-	-	-	276	275	31	268	222	31	265	165	31	262	108	31	-	-	-	-
	62	-	-	-	-	-	275	275	31	255	255	31	241	219	31	237	162	31	235	106	31	31
	57	-	-	-	-	-	275	275	31	255	255	31	235	235	31	217	214	31	211	159	30	30
12,000	77	-	-	-	-	-	-	-	-	-	-	-	-	-	-	-	-	-	-	-	-	-
	72	-	-	-	-	-	-	-	-	-	-	-	-	-	-	-	-	-	-	-	-	-
	67	-	-	-	-	-	-	-	-	275	246	31	270	180	31	266	114	31	-	-	-	-
	62	-	-	-	-	-	-	-	-	268	268	31	249	243	31	242	178	31	239	111	31	31
	57	-	-	-	-	-	-	-	-	268	268	31	247	247	31	227	227	31	216	175	31	31

**Table 21: 25 ton high capacity - 125°F ambient air temperature**

CFM	EWB (°F)	95°F EDB			90°F EDB			85°F EDB			80°F EDB			75°F EDB			70°F EDB			65°F EDB		
		TMBH	SMBH	kW	TMBH	SMBH	kW	TMBH	SMBH	kW	TMBH	SMBH	kW	TMBH	SMBH	kW	TMBH	SMBH	kW	TMBH	SMBH	kW
5,000	77	-	-	-	-	-	-	-	-	-	-	-	-	-	-	-	-	-	-	-	-	-
	72	239	189	35	238	162	35	237	134	35	236	106	35	235	78	35	-	-	-	-	-	-
	67	215	212	34	212	185	34	211	158	34	209	130	34	209	102	34	208	74	34	-	-	-
	62	213	213	34	199	199	34	187	181	34	185	153	34	184	126	34	183	98	34	182	70	34
	57	213	213	34	198	198	34	184	184	34	-	-	-	-	-	-	-	-	-	-	-	-
6,750	77	-	-	-	-	-	-	-	-	-	-	-	-	-	-	-	-	-	-	-	-	-
	72	-	-	-	-	-	-	-	-	-	-	-	-	-	-	-	-	-	-	-	-	-
	67	-	-	-	232	230	35	226	194	34	224	157	34	223	119	34	221	82	34	-	-	-
	62	-	-	-	230	230	35	214	214	34	201	190	34	198	153	34	197	116	34	195	78	34
	57	-	-	-	230	230	35	213	213	34	197	197	34	181	181	34	174	149	34	173	112	34
8,500	77	-	-	-	-	-	-	-	-	-	-	-	-	-	-	-	-	-	-	-	-	-
	72	-	-	-	-	-	-	-	-	-	-	-	-	-	-	-	-	-	-	-	-	-
	67	-	-	-	-	-	238	229	35	234	182	35	232	135	35	229	88	35	-	-	-	-
	62	-	-	-	-	-	235	235	35	217	217	34	208	179	34	206	132	34	203	85	34	34
	57	-	-	-	-	-	235	235	35	217	217	34	199	199	34	184	175	34	181	128	34	34
10,250	77	-	-	-	-	-	-	-	-	-	-	-	-	-	-	-	-	-	-	-	-	-
	72	-	-	-	-	-	-	-	-	-	-	-	-	-	-	-	-	-	-	-	-	-
	67	-	-	-	-	-	-	-	-	-	238	151	35	234	93	35	234	93	35	-	-	-
	62	-	-	-	-	-	-	-	-	232	232	35	216	204	34	211	148	34	208	91	34	34
	57	-	-	-	-	-	-	-	-	232	232	35	213	213	34	194	194	34	187	144	34	34
12,000	77	-	-	-	-	-	-	-	-	-	-	-	-	-	-	-	-	-	-	-	-	-
	72	-	-	-	-	-	-	-	-	-	-	-	-	-	-	-	-	-	-	-	-	-
	67	-	-	-	-	-	-	-	-	-	-	-	-	-	-	-	-	-	-	-	-	-
	62	-	-	-	-	-	-	-	-	-	-	-	223	223	34	216	163	34	211	96	34	34
	57	-	-	-	-	-	-	-	-	-	-	-	223	223	34	204	204	34	191	160	34	34

**Notes:**

Rated performance is at sea level. Cooling capacities are gross cooling capacities.  
 CFM = airflow, EWB = entering wet bulb air, EDB = entering dry bulb air, TMBH = total cooling capacity (MBH)  
 SMBH = sensible cooling capacity (MBH), kW = total input

## Cooling performance data 30 ton standard efficiency

**Table 22: 30 ton standard efficiency - 75°F ambient air temperature**

CFM	EWB (°F)	95°F EDB			90°F EDB			85°F EDB			80°F EDB			75°F EDB			70°F EDB			65°F EDB		
		TMBH	SMBH	kW	TMBH	SMBH	kW	TMBH	SMBH	kW	TMBH	SMBH	kW	TMBH	SMBH	kW	TMBH	SMBH	kW	TMBH	SMBH	kW
5,000	77	409	235	24	409	208	24	409	181	24	409	153	24	-	-	-	-	-	-	-	-	-
	72	373	263	24	374	236	24	374	209	24	374	182	24	374	155	24	-	-	-	-	-	-
	67	-	-	-	-	-	-	-	-	-	-	-	-	-	-	-	-	-	-	-	-	-
	62	-	-	-	-	-	-	-	-	-	-	-	-	-	-	-	-	-	-	-	-	-
	57	-	-	-	-	-	-	-	-	-	-	-	-	-	-	-	-	-	-	-	-	-
6,750	77	442	273	25	442	237	25	442	200	25	441	162	25	-	-	-	-	-	-	-	-	-
	72	406	311	24	406	275	24	406	238	24	406	202	24	405	164	24	-	-	-	-	-	-
	67	375	349	24	372	312	24	372	276	24	372	239	24	371	202	24	370	165	24	-	-	-
	62	365	365	24	-	-	-	-	-	-	-	-	-	-	-	-	-	-	-	-	-	-
	57	364	364	24	-	-	-	-	-	-	-	-	-	-	-	-	-	-	-	-	-	-
8,500	77	464	309	25	464	263	25	462	216	25	462	170	25	-	-	-	-	-	-	-	-	-
	72	428	357	24	427	311	24	426	265	24	426	219	24	424	172	24	-	-	-	-	-	-
	67	402	402	24	394	359	24	392	313	24	391	266	24	390	220	24	388	173	24	-	-	-
	62	402	402	24	381	381	24	362	357	24	357	310	24	355	264	24	354	217	24	352	170	24
	57	401	401	24	381	381	24	360	360	24	-	-	-	-	-	-	-	-	-	-	-	-
10,250	77	-	-	-	-	-	-	-	-	-	-	-	-	-	-	-	-	-	-	-	-	-
	72	445	403	25	442	347	25	440	291	25	439	235	25	438	179	25	-	-	-	-	-	-
	67	432	432	25	413	404	24	407	349	24	404	292	24	403	236	24	401	180	24	-	-	-
	62	431	431	25	410	410	24	387	387	24	372	346	24	368	290	24	367	234	24	365	177	24
	57	431	431	25	409	409	24	386	386	24	364	364	24	342	341	23	334	287	23	333	231	23
12,000	77	-	-	-	-	-	-	-	-	-	-	-	-	-	-	-	-	-	-	-	-	-
	72	461	447	25	454	382	25	451	317	25	449	251	25	447	185	25	-	-	-	-	-	-
	67	457	457	25	434	434	25	419	384	24	414	318	24	412	252	24	410	186	24	-	-	-
	62	456	456	25	433	433	25	409	409	24	385	381	24	378	316	24	375	250	24	373	184	24
	57	455	455	25	432	432	25	408	408	24	384	384	24	360	360	24	345	313	24	341	247	23

**Table 23: 30 ton standard efficiency - 85°F ambient air temperature**

CFM	EWB (°F)	95°F EDB			90°F EDB			85°F EDB			80°F EDB			75°F EDB			70°F EDB			65°F EDB		
		TMBH	SMBH	kW	TMBH	SMBH	kW	TMBH	SMBH	kW	TMBH	SMBH	kW	TMBH	SMBH	kW	TMBH	SMBH	kW	TMBH	SMBH	kW
5,000	77	394	229	27	394	202	27	394	175	27	395	147	27	-	-	-	-	-	-	-	-	-
	72	360	257	26	359	229	26	359	202	26	359	174	26	358	146	26	-	-	-	-	-	-
	67	325	279	26	324	252	26	323	224	26	322	197	26	322	169	26	321	141	26	-	-	-
	62	-	-	-	-	-	-	-	-	-	-	-	-	-	-	-	-	-	-	-	-	-
	57	-	-	-	-	-	-	-	-	-	-	-	-	-	-	-	-	-	-	-	-	-
6,750	77	425	267	27	425	230	27	425	193	27	424	156	27	-	-	-	-	-	-	-	-	-
	72	390	304	27	389	267	27	388	230	27	387	192	27	386	155	27	-	-	-	-	-	-
	67	356	337	26	352	300	26	351	263	26	350	226	26	350	188	26	348	151	26	-	-	-
	62	348	348	26	329	329	26	319	297	26	317	259	26	317	223	26	316	186	26	315	148	26
	57	347	347	26	329	329	26	-	-	-	-	-	-	-	-	-	-	-	-	-	-	-
8,500	77	445	303	27	445	256	27	443	210	27	443	163	27	-	-	-	-	-	-	-	-	-
	72	410	349	27	407	302	27	406	256	27	404	209	27	403	162	27	-	-	-	-	-	-
	67	385	385	27	373	346	27	369	299	26	368	252	26	367	205	26	365	158	26	-	-	-
	62	385	385	27	363	363	26	342	342	26	336	297	26	334	250	26	333	203	26	331	156	26
	57	384	384	27	363	363	26	342	342	26	322	322	26	-	-	-	-	-	-	-	-	-
10,250	77	-	-	-	-	-	-	-	-	-	-	-	-	-	-	-	-	-	-	-	-	-
	72	426	394	27	421	337	27	419	281	27	416	224	27	415	168	27	-	-	-	-	-	-
	67	415	415	27	391	389	27	383	334	27	380	278	27	378	221	27	376	165	27	-	-	-
	62	414	414	27	391	391	27	368	368	26	350	332	26	346	276	26	343	220	26	342	163	26
	57	414	414	27	390	390	27	368	368	26	345	345	26	323	323	26	314	274	26	312	217	26
12,000	77	-	-	-	-	-	-	-	-	-	-	-	-	-	-	-	-	-	-	-	-	-
	72	441	437	27	432	372	27	428	306	27	425	240	27	422	173	27	-	-	-	-	-	-
	67	439	439	27	413	413	27	395	369	27	389	303	27	386	237	27	384	171	27	-	-	-
	62	438	438	27	413	413	27	388	388	27	364	364	26	355	302	26	352	236	26	350	170	26
	57	438	438	27	413	413	27	388	388	27	364	364	26	341	341	26	324	300	26	319	234	26

**Table 24: 30 ton standard efficiency - 95°F ambient air temperature**

CFM	EWB (°F)	95°F EDB			90°F EDB			85°F EDB			80°F EDB			75°F EDB			70°F EDB			65°F EDB		
		TMBH	SMBH	kW	TMBH	SMBH	kW	TMBH	SMBH	kW	TMBH	SMBH	kW	TMBH	SMBH	kW	TMBH	SMBH	kW	TMBH	SMBH	kW
5,000	77	377	220	30	376	193	30	376	165	30	375	137	30	-	-	-	-	-	-	-	-	-
	72	339	243	29	338	215	29	338	188	29	337	160	29	336	132	29	-	-	-	-	-	-
	67	303	264	29	301	236	29	301	209	29	300	181	29	300	153	29	299	125	29	-	-	-
	62	-	-	-	-	-	-	-	-	-	-	-	-	-	-	-	-	-	-	-	-	-
	57	-	-	-	-	-	-	-	-	-	-	-	-	-	-	-	-	-	-	-	-	-
6,750	77	404	257	30	404	220	30	402	182	30	401	144	30	-	-	-	-	-	-	-	-	-
	72	366	290	30	365	253	30	364	215	30	363	178	30	362	140	29	-	-	-	-	-	-
	67	332	321	29	328	284	29	327	247	29	326	209	29	325	172	29	323	134	29	-	-	-
	62	329	329	29	310	310	29	298	281	29	295	244	29	294	207	29	294	170	29	292	133	29
	57	330	330	29	311	311	29	-	-	-	-	-	-	-	-	-	-	-	-	-	-	-
8,500	77	-	-	-	-	-	-	-	-	-	-	-	-	-	-	-	-	-	-	-	-	-
	72	385	335	30	382	288	30	381	241	30	379	194	30	377	147	30	-	-	-	-	-	-
	67	364	364	30	348	330	29	344	283	29	342	236	29	340	189	29	339	142	29	-	-	-
	62	364	364	30	343	343	29	322	322	29	312	281	29	310	234	29	309	188	29	307	141	29
	57	365	365	30	344	344	29	324	324	29	304	304	29	-	-	-	-	-	-	-	-	-
10,250	77	-	-	-	-	-	-	-	-	-	-	-	-	-	-	-	-	-	-	-	-	-
	72	400	379	30	395	323	30	392	266	30	390	210	30	387	153	30	-	-	-	-	-	-
	67	392	392	30	368	368	30	357	318	30	353	261	29	351	205	29	349	148	29	-	-	-
	62	393	393	30	369	369	30	346	346	29	326	317	29	321	260	29	319	204	29	317	147	29
	57	393	393	30	370	370	30	348	348	29	326	326	29	305	305	29	293	260	29	290	204	29
12,000	77	-	-	-	-	-	-	-	-	-	-	-	-	-	-	-	-	-	-	-	-	-
	72	-	-	-	405	358	30	400	291	30	397	225	30	394	158	30	-	-	-	-	-	-
	67	-	-	-	389	389	30	368	352	30	362	287	30	358	220	30	356	154	30	-	-	-
	62	-	-	-	390	390	30	366	366	30	342	342	29	330	286	29	326	220	29	324	153	29
	57	-	-	-	391	391	30	367	367	30	344	344	29	321	321	29	302	286	29	297	220	29

**Table 25: 30 ton standard efficiency - 105°F ambient air temperature**

CFM	EWB (°F)	95°F EDB			90°F EDB			85°F EDB			80°F EDB			75°F EDB			70°F EDB			65°F EDB		
		TMBH	SMBH	kW	TMBH	SMBH	kW	TMBH	SMBH	kW	TMBH	SMBH	kW	TMBH	SMBH	kW	TMBH	SMBH	kW	TMBH	SMBH	kW
5,000	77	354	207	33	353	180	33	353	152	33	352	124	33	-	-	-	-	-	-	-	-	-
	72	317	230	32	317	203	32	317	175	32	316	148	32	315	119	32	-	-	-	-	-	-
	67	283	251	32	282	224	32	281	196	32	281	169	32	280	141	32	279	113	32	-	-	-
	62	-	-	-	-	-	-	-	-	-	-	-	-	-	-	-	-	-	-	-	-	-
	57	-	-	-	-	-	-	-	-	-	-	-	-	-	-	-	-	-	-	-	-	-
6,750	77	379	244	33	378	206	33	377	169	33	376	131	33	-	-	-	-	-	-	-	-	-
	72	343	277	33	342	240	33	341	203	33	339	165	33	338	128	33	-	-	-	-	-	-
	67	312	308	32	307	271	32	305	234	32	304	197	32	303	160	32	302	122	32	-	-	-
	62	311	311	32	293	293	32	278	269	32	275	232	32	274	195	32	274	158	32	272	121	32
	57	312	312	32	293	293	32	275	275	32	-	-	-	-	-	-	-	-	-	-	-	-
8,500	77	-	-	-	-	-	-	-	-	-	-	-	-	-	-	-	-	-	-	-	-	-
	72	361	322	33	357	275	33	356	228	33	354	181	33	352	134	33	-	-	-	-	-	-
	67	344	344	33	326	317	33	321	270	33	319	223	33	317	176	33	316	129	33	-	-	-
	62	345	345	33	324	324	33	304	304	32	292	269	32	289	222	32	287	175	32	286	128	32
	57	345	345	33	325	325	33	304	304	32	285	285	32	265	265	32	260	220	32	258	173	32
10,250	77	-	-	-	-	-	-	-	-	-	-	-	-	-	-	-	-	-	-	-	-	-
	72	376	366	33	369	310	33	366	253	33	364	197	33	361	140	33	-	-	-	-	-	-
	67	371	371	33	348	348	33	333	305	33	329	249	33	327	192	33	324	135	33	-	-	-
	62	372	372	33	349	349	33	327	327	33	306	303	32	299	248	32	296	191	32	294	135	32
	57	372	372	33	349	349	33	327	327	33	306	306	32	285	285	32	271	246	32	267	189	32
12,000	77	-	-	-	-	-	-	-	-	-	-	-	-	-	-	-	-	-	-	-	-	-
	72	-	-	-	-	-	-	373	278	33	371	212	33	368	145	33	-	-	-	-	-	-
	67	-	-	-	368	368	33	345	339	33	337	274	33	334	208	33	331	141	33	-	-	-
	62	-	-	-	369	369	33	345	345	33	322	322	33	307	273	32	303	207	32	301	141	32
	57	-	-	-	369	369	33	345	345	33	322	322	33	300	300	32	280	271	32	274	206	32

**Table 26: 30 ton standard efficiency - 115°F ambient air temperature**

CFM	EWB (°F)	95°F EDB			90°F EDB			85°F EDB			80°F EDB			75°F EDB			70°F EDB			65°F EDB		
		TMBH	SMBH	kW	TMBH	SMBH	kW	TMBH	SMBH	kW	TMBH	SMBH	kW	TMBH	SMBH	kW	TMBH	SMBH	kW	TMBH	SMBH	kW
5,000	77	329	194	37	328	166	37	327	138	37	327	110	37	-	-	-	-	-	-	-	-	-
	72	295	217	36	294	190	36	294	162	36	293	134	36	292	106	36	-	-	-	-	-	-
	67	264	240	36	263	213	36	262	185	36	262	158	36	261	130	36	260	102	36	-	-	-
	62	251	251	36	-	-	-	-	-	-	-	-	-	-	-	-	-	-	-	-	-	-
	57	251	251	35	-	-	-	-	-	-	-	-	-	-	-	-	-	-	-	-	-	-
6,750	77	-	-	-	-	-	-	-	-	-	-	-	-	-	-	-	-	-	-	-	-	-
	72	318	263	37	317	226	37	316	189	37	314	152	37	313	114	37	-	-	-	-	-	-
	67	293	293	36	286	260	36	284	223	36	283	186	36	282	148	36	281	111	36	-	-	-
	62	293	293	36	275	275	36	258	256	36	254	219	36	252	182	36	251	145	36	246	106	36
	57	292	292	36	274	274	36	256	256	36	239	239	35	-	-	-	-	-	-	-	-	-
8,500	77	-	-	-	-	-	-	-	-	-	-	-	-	-	-	-	-	-	-	-	-	-
	72	335	309	37	331	262	37	329	215	37	328	168	37	325	120	37	-	-	-	-	-	-
	67	325	325	37	305	304	36	298	259	36	296	212	36	294	165	36	292	118	36	-	-	-
	62	324	324	37	304	304	36	284	284	36	269	255	36	265	209	36	264	162	36	262	115	36
	57	324	324	37	303	303	36	284	284	36	264	264	36	245	245	36	237	205	35	235	158	35
10,250	77	-	-	-	-	-	-	-	-	-	-	-	-	-	-	-	-	-	-	-	-	-
	72	-	-	-	-	-	338	240	37	336	183	37	334	126	37	-	-	-	-	-	-	-
	67	-	-	-	328	328	37	310	294	37	305	237	36	303	181	36	301	124	36	-	-	-
	62	-	-	-	327	327	37	305	305	36	284	284	36	275	234	36	272	178	36	270	121	36
	57	-	-	-	326	326	37	305	305	36	284	284	36	263	263	36	247	231	36	243	175	36
12,000	77	-	-	-	-	-	-	-	-	-	-	-	-	-	-	-	-	-	-	-	-	-
	72	-	-	-	-	-	-	-	-	-	-	-	339	132	37	-	-	-	-	-	-	-
	67	-	-	-	-	-	323	323	37	312	262	37	309	196	37	306	130	37	-	-	-	-
	62	-	-	-	-	-	322	322	37	300	300	36	282	259	36	278	194	36	276	127	36	36
	57	-	-	-	-	-	322	322	37	299	299	36	277	277	36	255	254	36	249	191	36	36

**Table 27: 30 ton standard efficiency - 125°F ambient air temperature**

CFM	EWB (°F)	95°F EDB			90°F EDB			85°F EDB			80°F EDB			75°F EDB			70°F EDB			65°F EDB		
		TMBH	SMBH	kW	TMBH	SMBH	kW	TMBH	SMBH	kW	TMBH	SMBH	kW	TMBH	SMBH	kW	TMBH	SMBH	kW	TMBH	SMBH	kW
5,000	77	-	-	-	-	-	-	-	-	-	-	-	-	-	-	-	-	-	-	-	-	-
	72	-	-	-	-	-	-	-	-	-	-	-	-	-	-	-	-	-	-	-	-	-
	67	240	226	40	239	198	40	238	171	40	237	143	40	236	116	40	236	88	40	-	-	-
	62	232	232	40	217	217	40	210	194	40	209	166	40	209	139	40	208	111	40	207	83	40
	57	232	232	40	217	217	40	-	-	-	-	-	-	-	-	-	-	-	-	-	-	-
6,750	77	-	-	-	-	-	-	-	-	-	-	-	-	-	-	-	-	-	-	-	-	-
	72	-	-	-	-	-	-	-	-	-	-	-	-	-	-	-	-	-	-	-	-	-
	67	-	-	-	-	-	-	-	-	-	-	-	-	-	-	-	-	-	-	-	-	-
	62	-	-	-	-	-	236	236	40	229	204	40	227	167	40	226	130	40	224	92	40	40
	57	-	-	-	-	-	235	235	40	218	218	40	-	-	-	-	-	-	-	-	-	-
8,500	77	-	-	-	-	-	-	-	-	-	-	-	-	-	-	-	-	-	-	-	-	-
	72	-	-	-	-	-	-	-	-	-	-	-	-	-	-	-	-	-	-	-	-	-
	67	-	-	-	-	-	-	-	-	-	-	-	-	-	-	-	-	-	-	-	-	-
	62	-	-	-	-	-	-	-	-	-	-	-	-	-	-	237	146	40	235	99	40	40
	57	-	-	-	-	-	-	-	-	-	-	-	223	223	40	212	189	40	209	142	40	40
10,250	77	-	-	-	-	-	-	-	-	-	-	-	-	-	-	-	-	-	-	-	-	-
	72	-	-	-	-	-	-	-	-	-	-	-	-	-	-	-	-	-	-	-	-	-
	67	-	-	-	-	-	-	-	-	-	-	-	-	-	-	-	-	-	-	-	-	-
	62	-	-	-	-	-	-	-	-	-	-	-	-	-	-	-	-	-	-	-	-	-
	57	-	-	-	-	-	-	-	-	-	-	-	-	-	-	221	215	40	217	159	40	40
12,000	77	-	-	-	-	-	-	-	-	-	-	-	-	-	-	-	-	-	-	-	-	-
	72	-	-	-	-	-	-	-	-	-	-	-	-	-	-	-	-	-	-	-	-	-
	67	-	-	-	-	-	-	-	-	-	-	-	-	-	-	-	-	-	-	-	-	-
	62	-	-	-	-	-	-	-	-	-	-	-	-	-	-	-	-	-	-	-	-	-
	57	-	-	-	-	-	-	-	-	-	-	-	-	-	-	231	231	40	222	175	40	40

**Notes:**  
 Rated performance is at sea level. Cooling capacities are gross cooling capacities.  
 CFM = airflow, EWB = entering wet bulb air, EDB = entering dry bulb air, TMBH = total cooling capacity (MBH)  
 SMBH = sensible cooling capacity (MBH), kW = total input

## Cooling performance data 30 ton high efficiency

**Table 28: 30 ton high efficiency - 75°F ambient air temperature**

CFM	EWB (°F)	95°F EDB			90°F EDB			85°F EDB			80°F EDB			75°F EDB			70°F EDB			65°F EDB		
		TMBH	SMBH	kW	TMBH	SMBH	kW	TMBH	SMBH	kW	TMBH	SMBH	kW	TMBH	SMBH	kW	TMBH	SMBH	kW	TMBH	SMBH	kW
5,000	77	398	225	23	398	198	23	397	170	23	397	142	23	-	-	-	-	-	-	-	-	-
	72	363	253	23	362	226	23	362	198	23	361	170	23	361	142	23	-	-	-	-	-	-
	67	-	-	-	-	-	-	-	-	-	-	-	-	-	-	-	-	-	-	-	-	-
	62	-	-	-	-	-	-	-	-	-	-	-	-	-	-	-	-	-	-	-	-	-
	57	-	-	-	-	-	-	-	-	-	-	-	-	-	-	-	-	-	-	-	-	-
6,750	77	435	267	23	435	229	23	434	192	23	432	154	23	-	-	-	-	-	-	-	-	-
	72	398	304	23	397	267	23	397	230	23	396	193	23	395	155	23	-	-	-	-	-	-
	67	366	342	23	363	304	23	362	267	23	362	230	23	361	193	23	358	157	23	-	-	-
	62	356	356	23	-	-	-	-	-	-	-	-	-	-	-	-	-	-	-	-	-	-
	57	355	355	23	-	-	-	-	-	-	-	-	-	-	-	-	-	-	-	-	-	-
8,500	77	-	-	-	-	-	-	-	-	-	-	-	-	-	-	-	-	-	-	-	-	-
	72	422	353	23	420	306	23	419	259	23	418	212	23	416	165	23	-	-	-	-	-	-
	67	396	396	23	387	353	23	384	306	23	383	259	23	382	213	23	381	165	23	-	-	-
	62	395	395	23	375	375	23	356	354	23	352	306	23	350	260	23	349	213	23	345	165	23
	57	394	394	23	374	374	23	355	355	23	-	-	-	-	-	-	-	-	-	-	-	-
10,250	77	-	-	-	-	-	-	-	-	-	-	-	-	-	-	-	-	-	-	-	-	-
	72	440	400	23	436	343	23	434	286	23	432	230	23	431	172	23	-	-	-	-	-	-
	67	427	427	23	406	401	23	400	344	23	398	287	23	396	230	23	395	174	23	-	-	-
	62	426	426	23	404	404	23	383	383	23	368	344	23	364	287	23	362	231	23	361	174	23
	57	426	426	23	404	404	23	382	382	23	361	361	23	341	341	22	333	287	22	331	231	22
12,000	77	-	-	-	-	-	-	-	-	-	-	-	-	-	-	-	-	-	-	-	-	-
	72	-	-	-	-	-	-	-	-	-	443	246	23	441	180	23	-	-	-	-	-	-
	67	-	-	-	429	429	23	413	380	23	409	314	23	407	247	23	404	181	23	-	-	-
	62	-	-	-	428	428	23	405	405	23	382	380	23	375	314	23	372	248	23	370	182	23
	57	-	-	-	428	428	23	404	404	23	381	381	23	359	359	23	344	315	22	341	248	22

**Table 29: 30 ton high efficiency - 85°F ambient air temperature**

CFM	EWB (°F)	95°F EDB			90°F EDB			85°F EDB			80°F EDB			75°F EDB			70°F EDB			65°F EDB		
		TMBH	SMBH	kW	TMBH	SMBH	kW	TMBH	SMBH	kW	TMBH	SMBH	kW	TMBH	SMBH	kW	TMBH	SMBH	kW	TMBH	SMBH	kW
5,000	77	382	218	26	382	190	26	381	162	26	381	134	26	-	-	-	-	-	-	-	-	-
	72	347	245	25	347	217	25	346	189	25	346	161	25	345	133	25	-	-	-	-	-	-
	67	314	270	25	314	242	25	313	215	25	312	187	25	312	159	25	311	131	25	-	-	-
	62	-	-	-	-	-	-	-	-	-	-	-	-	-	-	-	-	-	-	-	-	-
	57	-	-	-	-	-	-	-	-	-	-	-	-	-	-	-	-	-	-	-	-	-
6,750	77	-	-	-	-	-	-	415	183	26	414	145	26	-	-	-	-	-	-	-	-	-
	72	381	295	25	380	258	25	379	221	25	378	184	25	377	146	25	-	-	-	-	-	-
	67	348	332	25	346	294	25	344	257	25	344	219	25	343	182	25	342	144	25	-	-	-
	62	343	343	25	326	326	25	316	295	25	315	258	25	314	221	25	313	184	25	312	146	25
	57	343	343	25	326	326	25	-	-	-	-	-	-	-	-	-	-	-	-	-	-	-
8,500	77	-	-	-	-	-	-	-	-	-	-	-	-	-	-	-	-	-	-	-	-	-
	72	403	344	26	401	297	26	400	250	26	398	202	26	397	155	26	-	-	-	-	-	-
	67	380	380	25	368	343	25	365	296	25	364	249	25	362	202	25	361	154	25	-	-	-
	62	380	380	25	361	361	25	341	341	25	335	297	25	333	250	25	332	203	25	331	156	25
	57	380	380	25	360	360	25	341	341	25	323	323	25	-	-	-	-	-	-	-	-	-
10,250	77	-	-	-	-	-	-	-	-	-	-	-	-	-	-	-	-	-	-	-	-	-
	72	-	-	-	416	334	26	414	277	26	412	220	26	410	163	26	-	-	-	-	-	-
	67	411	411	26	389	389	26	381	333	25	378	276	25	376	219	25	374	162	25	-	-	-
	62	411	411	26	389	389	26	367	367	25	350	335	25	347	278	25	344	221	25	343	164	25
	57	410	410	26	389	389	26	367	367	25	347	347	25	326	326	25	317	278	25	315	221	25
12,000	77	-	-	-	-	-	-	-	-	-	-	-	-	-	-	-	-	-	-	-	-	-
	72	-	-	-	-	-	-	-	-	-	-	-	-	-	-	-	-	-	-	-	-	-
	67	-	-	-	412	412	26	393	370	26	389	303	26	386	237	26	383	170	26	-	-	-
	62	-	-	-	412	412	26	389	389	26	366	366	25	357	305	25	354	238	25	351	172	25
	57	-	-	-	411	411	26	388	388	26	366	366	25	344	344	25	328	305	25	324	239	25

**Table 30: 30 ton high efficiency - 95°F ambient air temperature**

CFM	EWB (°F)	95°F EDB			90°F EDB			85°F EDB			80°F EDB			75°F EDB			70°F EDB			65°F EDB		
		TMBH	SMBH	kW	TMBH	SMBH	kW	TMBH	SMBH	kW	TMBH	SMBH	kW	TMBH	SMBH	kW	TMBH	SMBH	kW	TMBH	SMBH	kW
5,000	77	365	209	28	365	181	28	364	153	28	363	125	28	-	-	-	-	-	-	-	-	-
	72	329	234	28	328	206	28	328	179	28	327	151	28	326	122	28	-	-	-	-	-	-
	67	296	258	27	295	231	27	294	203	27	294	175	27	293	147	27	292	119	27	-	-	-
	62	-	-	-	-	-	-	-	-	-	-	-	-	-	-	-	-	-	-	-	-	-
	57	-	-	-	-	-	-	-	-	-	-	-	-	-	-	-	-	-	-	-	-	-
6,750	77	-	-	-	-	-	-	-	-	-	-	-	-	-	-	-	-	-	-	-	-	-
	72	361	285	28	360	247	28	359	210	28	358	173	28	357	135	28	-	-	-	-	-	-
	67	329	320	28	326	282	28	324	245	28	323	207	28	322	170	28	321	132	28	-	-	-
	62	327	327	28	310	310	28	299	284	27	297	247	27	296	209	27	295	172	27	289	133	27
	57	329	329	28	312	312	28	-	-	-	-	-	-	-	-	-	-	-	-	-	-	-
8,500	77	-	-	-	-	-	-	-	-	-	-	-	-	-	-	-	-	-	-	-	-	-
	72	382	333	29	380	286	29	378	239	29	377	192	29	375	144	28	-	-	-	-	-	-
	67	362	362	28	348	331	28	344	284	28	342	237	28	341	189	28	339	142	28	-	-	-
	62	364	364	28	344	344	28	325	325	28	316	286	28	314	239	28	312	191	28	311	144	28
	57	365	365	28	346	346	28	327	327	28	308	308	28	-	-	-	-	-	-	-	-	-
10,250	77	-	-	-	-	-	-	-	-	-	-	-	-	-	-	-	-	-	-	-	-	-
	72	-	-	-	-	-	-	-	-	-	-	-	-	387	152	29	-	-	-	-	-	-
	67	-	-	-	370	370	28	359	321	28	356	264	28	353	207	28	351	150	28	-	-	-
	62	-	-	-	371	371	28	350	350	28	331	323	28	326	266	28	324	209	28	322	153	28
	57	-	-	-	372	372	28	351	351	28	331	331	28	311	311	28	300	268	27	297	211	27
12,000	77	-	-	-	-	-	-	-	-	-	-	-	-	-	-	-	-	-	-	-	-	-
	72	-	-	-	-	-	-	-	-	-	-	-	-	-	-	-	-	-	-	-	-	-
	67	-	-	-	-	-	-	372	358	28	366	291	28	363	224	28	360	157	28	-	-	-
	62	-	-	-	-	-	-	370	370	28	348	348	28	336	293	28	333	227	28	330	160	28
	57	-	-	-	-	-	-	371	371	28	349	349	28	328	328	28	310	295	28	306	229	28

**Table 31: 30 ton high efficiency - 105°F ambient air temperature**

CFM	EWB (°F)	95°F EDB			90°F EDB			85°F EDB			80°F EDB			75°F EDB			70°F EDB			65°F EDB		
		TMBH	SMBH	kW	TMBH	SMBH	kW	TMBH	SMBH	kW	TMBH	SMBH	kW	TMBH	SMBH	kW	TMBH	SMBH	kW	TMBH	SMBH	kW
5,000	77	347	200	32	346	173	32	345	145	32	344	116	32	-	-	-	-	-	-	-	-	-
	72	314	227	31	313	199	31	313	172	31	312	144	31	311	116	31	-	-	-	-	-	-
	67	283	252	31	281	224	31	281	196	31	280	169	31	280	141	31	278	113	31	-	-	-
	62	-	-	-	-	-	-	-	-	-	-	-	-	-	-	-	-	-	-	-	-	-
	57	-	-	-	-	-	-	-	-	-	-	-	-	-	-	-	-	-	-	-	-	-
6,750	77	-	-	-	-	-	-	-	-	-	-	-	-	-	-	-	-	-	-	-	-	-
	72	343	277	31	342	240	31	341	202	31	339	165	31	338	127	31	-	-	-	-	-	-
	67	313	312	31	310	275	31	308	237	31	307	200	31	306	163	31	305	125	31	-	-	-
	62	314	314	31	297	297	31	284	276	31	281	239	30	280	202	30	280	164	30	278	127	30
	57	314	314	31	298	298	31	281	281	30	-	-	-	-	-	-	-	-	-	-	-	-
8,500	77	-	-	-	-	-	-	-	-	-	-	-	-	-	-	-	-	-	-	-	-	-
	72	-	-	-	360	278	32	358	231	32	357	183	32	355	136	32	-	-	-	-	-	-
	67	348	348	32	330	323	31	326	276	31	324	229	31	323	182	31	321	134	31	-	-	-
	62	348	348	32	329	329	31	311	311	31	299	277	31	297	230	31	295	183	31	293	136	31
	57	348	348	31	329	329	31	311	311	31	293	293	31	275	275	30	270	230	30	269	184	30
10,250	77	-	-	-	-	-	-	-	-	-	-	-	-	-	-	-	-	-	-	-	-	-
	72	-	-	-	-	-	-	-	-	-	-	-	-	-	-	-	-	-	-	-	-	-
	67	-	-	-	354	354	32	340	313	31	336	256	31	334	199	31	332	142	31	-	-	-
	62	-	-	-	355	355	32	334	334	31	314	314	31	308	258	31	306	201	31	304	144	31
	57	-	-	-	355	355	32	334	334	31	314	314	31	295	295	31	282	258	30	279	201	30
12,000	77	-	-	-	-	-	-	-	-	-	-	-	-	-	-	-	-	-	-	-	-	-
	72	-	-	-	-	-	-	-	-	-	-	-	-	-	-	-	-	-	-	-	-	-
	67	-	-	-	-	-	-	352	349	32	345	282	31	342	216	31	339	149	31	-	-	-
	62	-	-	-	-	-	-	353	353	32	331	331	31	317	284	31	314	218	31	311	151	31
	57	-	-	-	-	-	-	353	353	32	331	331	31	310	310	31	291	285	31	286	218	31

**Table 32: 30 ton high efficiency - 115°F ambient air temperature**

CFM	EWB (°F)	95°F EDB			90°F EDB			85°F EDB			80°F EDB			75°F EDB			70°F EDB			65°F EDB		
		TMBH	SMBH	kW	TMBH	SMBH	kW	TMBH	SMBH	kW	TMBH	SMBH	kW	TMBH	SMBH	kW	TMBH	SMBH	kW	TMBH	SMBH	kW
5,000	77	326	191	35	326	163	35	325	135	35	324	107	35	-	-	-	-	-	-	-	-	-
	72	296	218	35	295	191	35	295	163	35	294	135	35	293	107	35	-	-	-	-	-	-
	67	268	245	34	267	218	34	267	190	34	266	163	34	265	135	34	265	107	34	-	-	-
	62	257	257	34	-	-	-	-	-	-	-	-	-	-	-	-	-	-	-	-	-	-
	57	257	257	34	-	-	-	-	-	-	-	-	-	-	-	-	-	-	-	-	-	-
6,750	77	-	-	-	-	-	-	-	-	-	-	-	-	-	-	-	-	-	-	-	-	-
	72	322	268	35	321	231	35	320	193	35	319	156	35	317	118	35	-	-	-	-	-	-
	67	300	300	35	293	268	34	291	230	34	290	193	34	289	156	34	288	118	34	-	-	-
	62	299	299	35	283	283	34	267	267	34	264	230	34	263	192	34	262	155	34	256	116	34
	57	298	298	35	282	282	34	266	266	34	251	251	34	-	-	-	-	-	-	-	-	-
8,500	77	-	-	-	-	-	-	-	-	-	-	-	-	-	-	-	-	-	-	-	-	-
	72	-	-	-	-	-	-	-	-	-	-	-	-	-	-	-	-	-	-	-	-	-
	67	332	332	35	313	313	35	307	268	35	305	221	35	304	174	35	302	127	35	-	-	-
	62	331	331	35	313	313	35	294	294	34	280	268	34	277	221	34	276	174	34	274	127	34
	57	330	330	35	312	312	35	294	294	34	276	276	34	259	259	34	251	220	34	250	173	34
10,250	77	-	-	-	-	-	-	-	-	-	-	-	-	-	-	-	-	-	-	-	-	-
	72	-	-	-	-	-	-	-	-	-	-	-	-	-	-	-	-	-	-	-	-	-
	67	-	-	-	-	-	-	320	305	35	316	248	35	314	191	35	311	134	35	-	-	-
	62	-	-	-	-	-	-	316	316	35	297	297	34	288	248	34	285	191	34	283	134	34
	57	-	-	-	-	-	-	315	315	35	296	296	34	277	277	34	262	247	34	259	190	34
12,000	77	-	-	-	-	-	-	-	-	-	-	-	-	-	-	-	-	-	-	-	-	-
	72	-	-	-	-	-	-	-	-	-	-	-	-	-	-	-	-	-	-	-	-	-
	67	-	-	-	-	-	-	-	-	-	324	274	35	321	208	35	318	141	35	-	-	-
	62	-	-	-	-	-	-	-	-	-	312	312	35	296	274	34	292	208	34	289	141	34
	57	-	-	-	-	-	-	-	-	-	312	312	35	291	291	34	271	271	34	266	207	34

**Table 33: 30 ton high efficiency - 125°F ambient air temperature**

CFM	EWB (°F)	95°F EDB			90°F EDB			85°F EDB			80°F EDB			75°F EDB			70°F EDB			65°F EDB		
		TMBH	SMBH	kW	TMBH	SMBH	kW	TMBH	SMBH	kW	TMBH	SMBH	kW	TMBH	SMBH	kW	TMBH	SMBH	kW	TMBH	SMBH	kW
5,000	77	-	-	-	-	-	-	-	-	-	-	-	-	-	-	-	-	-	-	-	-	-
	72	-	-	-	-	-	-	-	-	-	-	-	-	-	-	-	-	-	-	-	-	-
	67	249	235	38	248	208	38	247	180	38	247	153	38	246	125	38	245	97	38	-	-	-
	62	243	243	38	229	229	38	223	207	37	222	179	37	222	151	37	221	124	37	220	96	37
	57	242	242	38	229	229	38	-	-	-	-	-	-	-	-	-	-	-	-	-	-	-
6,750	77	-	-	-	-	-	-	-	-	-	-	-	-	-	-	-	-	-	-	-	-	-
	72	-	-	-	-	-	-	-	-	-	-	-	-	-	-	-	-	-	-	-	-	-
	67	-	-	-	-	-	-	-	-	-	268	182	38	267	145	38	266	107	38	-	-	-
	62	-	-	-	265	265	38	250	250	38	243	219	38	242	182	38	241	144	38	240	107	38
	57	-	-	-	265	265	38	249	249	38	234	234	38	-	-	-	-	-	-	-	-	-
8,500	77	-	-	-	-	-	-	-	-	-	-	-	-	-	-	-	-	-	-	-	-	-
	72	-	-	-	-	-	-	-	-	-	-	-	-	-	-	-	-	-	-	-	-	-
	67	-	-	-	-	-	-	-	-	-	-	-	-	-	-	-	-	-	-	-	-	-
	62	-	-	-	-	-	-	-	-	-	259	257	38	255	210	38	254	163	38	252	115	38
	57	-	-	-	-	-	-	-	-	-	258	258	38	241	241	38	231	209	38	229	162	38
10,250	77	-	-	-	-	-	-	-	-	-	-	-	-	-	-	-	-	-	-	-	-	-
	72	-	-	-	-	-	-	-	-	-	-	-	-	-	-	-	-	-	-	-	-	-
	67	-	-	-	-	-	-	-	-	-	-	-	-	-	-	-	-	-	-	-	-	-
	62	-	-	-	-	-	-	-	-	-	-	-	-	264	236	38	262	180	38	259	123	38
	57	-	-	-	-	-	-	-	-	-	-	-	-	257	257	38	240	235	38	237	179	38
12,000	77	-	-	-	-	-	-	-	-	-	-	-	-	-	-	-	-	-	-	-	-	-
	72	-	-	-	-	-	-	-	-	-	-	-	-	-	-	-	-	-	-	-	-	-
	67	-	-	-	-	-	-	-	-	-	-	-	-	-	-	-	-	-	-	-	-	-
	62	-	-	-	-	-	-	-	-	-	-	-	-	-	-	-	268	196	38	265	129	38
	57	-	-	-	-	-	-	-	-	-	-	-	-	-	-	-	251	251	38	243	196	38

**Notes:**  
 Rated performance is at sea level. Cooling capacities are gross cooling capacities.  
 CFM = airflow, EWB = entering wet bulb air, EDB = entering dry bulb air, TMBH = total cooling capacity (MBH)  
 SMBH = sensible cooling capacity (MBH), kW = total input

## Cooling performance data 30 ton high capacity

**Table 34: 30 ton high capacity - 75°F ambient air temperature**

CFM	EWB (°F)	95°F EDB			90°F EDB			85°F EDB			80°F EDB			75°F EDB			70°F EDB			65°F EDB		
		TMBH	SMBH	kW	TMBH	SMBH	kW	TMBH	SMBH	kW	TMBH	SMBH	kW	TMBH	SMBH	kW	TMBH	SMBH	kW	TMBH	SMBH	kW
5,000	77	435	247	26	436	220	26	436	193	26	436	165	26	-	-	-	-	-	-	-	-	-
	72	397	275	25	397	248	25	397	221	25	398	194	25	398	166	25	-	-	-	-	-	-
	67	-	-	-	-	-	-	-	-	-	-	-	-	-	-	-	-	-	-	-	-	-
	62	-	-	-	-	-	-	-	-	-	-	-	-	-	-	-	-	-	-	-	-	-
	57	-	-	-	-	-	-	-	-	-	-	-	-	-	-	-	-	-	-	-	-	-
6,750	77	475	287	26	475	250	26	475	213	26	474	176	26	-	-	-	-	-	-	-	-	-
	72	435	324	26	435	288	26	435	252	26	435	215	26	434	178	26	-	-	-	-	-	-
	67	400	362	25	399	326	25	398	289	25	398	252	25	398	215	25	397	178	25	-	-	-
	62	-	-	-	-	-	-	-	-	-	-	-	-	-	-	-	-	-	-	-	-	-
	57	-	-	-	-	-	-	-	-	-	-	-	-	-	-	-	-	-	-	-	-	-
8,500	77	-	-	-	-	-	-	-	-	-	-	-	-	-	-	-	-	-	-	-	-	-
	72	460	372	26	459	325	26	459	279	26	459	233	26	458	186	26	-	-	-	-	-	-
	67	428	420	26	423	373	26	422	327	26	421	280	25	420	234	25	419	187	25	-	-	-
	62	425	425	26	403	403	25	386	371	25	383	324	25	382	277	25	381	231	25	380	184	25
	57	424	424	26	402	402	25	380	380	25	-	-	-	-	-	-	-	-	-	-	-	-
10,250	77	-	-	-	-	-	-	-	-	-	-	-	-	-	-	-	-	-	-	-	-	-
	72	479	418	26	477	362	26	476	306	26	475	250	26	474	193	26	-	-	-	-	-	-
	67	459	459	26	442	420	26	439	363	26	437	307	26	436	251	26	434	194	26	-	-	-
	62	458	458	26	435	435	26	411	411	25	400	361	25	397	304	25	396	248	25	394	192	25
	57	457	457	26	434	434	26	410	410	25	386	386	25	-	-	-	-	-	-	-	-	-
12,000	77	-	-	-	-	-	-	-	-	-	-	-	-	-	-	-	-	-	-	-	-	-
	72	495	464	27	490	397	27	488	332	27	486	266	26	485	200	26	-	-	-	-	-	-
	67	486	486	26	462	462	26	452	399	26	449	333	26	446	267	26	444	200	26	-	-	-
	62	485	485	26	461	461	26	435	435	26	414	397	25	409	331	25	406	264	25	405	198	25
	57	484	484	26	460	460	26	434	434	26	409	409	25	384	384	25	372	328	25	369	262	25

**Table 35: 30 ton high capacity - 85°F ambient air temperature**

CFM	EWB (°F)	95°F EDB			90°F EDB			85°F EDB			80°F EDB			75°F EDB			70°F EDB			65°F EDB		
		TMBH	SMBH	kW	TMBH	SMBH	kW	TMBH	SMBH	kW	TMBH	SMBH	kW	TMBH	SMBH	kW	TMBH	SMBH	kW	TMBH	SMBH	kW
5,000	77	421	241	28	421	214	28	421	186	28	421	159	28	-	-	-	-	-	-	-	-	-
	72	383	268	28	383	240	28	382	213	28	382	185	28	382	157	28	-	-	-	-	-	-
	67	-	-	-	-	-	-	-	-	-	-	-	-	-	-	-	-	-	-	-	-	-
	62	-	-	-	-	-	-	-	-	-	-	-	-	-	-	-	-	-	-	-	-	-
	57	-	-	-	-	-	-	-	-	-	-	-	-	-	-	-	-	-	-	-	-	-
6,750	77	458	280	29	458	243	29	458	206	29	457	169	29	-	-	-	-	-	-	-	-	-
	72	418	317	28	418	280	28	417	243	28	417	205	28	415	167	28	-	-	-	-	-	-
	67	378	348	28	376	310	28	375	273	28	374	236	28	373	199	28	372	161	28	-	-	-
	62	365	365	28	-	-	-	-	-	-	-	-	-	-	-	-	-	-	-	-	-	-
	57	365	365	28	-	-	-	-	-	-	-	-	-	-	-	-	-	-	-	-	-	-
8,500	77	-	-	-	-	-	-	-	-	-	-	-	-	-	-	-	-	-	-	-	-	-
	72	442	363	29	440	316	29	439	270	29	438	222	29	436	175	29	-	-	-	-	-	-
	67	406	405	28	399	358	28	396	311	28	395	264	28	394	217	28	392	169	28	-	-	-
	62	406	406	28	383	383	28	364	356	28	360	309	28	359	262	28	358	215	28	353	167	28
	57	406	406	28	384	384	28	362	362	28	-	-	-	-	-	-	-	-	-	-	-	-
10,250	77	-	-	-	-	-	-	-	-	-	-	-	-	-	-	-	-	-	-	-	-	-
	72	459	409	29	456	352	29	454	295	29	452	239	29	450	182	29	-	-	-	-	-	-
	67	439	439	29	417	404	28	412	347	28	410	290	28	408	233	28	406	176	28	-	-	-
	62	439	439	29	414	414	28	390	390	28	376	346	28	373	289	28	371	232	28	370	176	28
	57	439	439	29	414	414	28	391	391	28	367	367	28	345	344	27	339	287	27	338	231	27
12,000	77	-	-	-	-	-	-	-	-	-	-	-	-	-	-	-	-	-	-	-	-	-
	72	-	-	-	468	387	29	465	321	29	462	254	29	459	187	29	-	-	-	-	-	-
	67	-	-	-	439	439	29	425	382	29	421	316	29	418	249	28	415	182	28	-	-	-
	62	467	467	29	440	440	29	414	414	28	390	382	28	384	315	28	381	249	28	379	182	28
	57	466	466	29	440	440	29	414	414	28	389	389	28	364	364	28	350	314	27	347	248	27

**Table 36: 30 ton high capacity - 95°F ambient air temperature**

CFM	EWB (°F)	95°F EDB			90°F EDB			85°F EDB			80°F EDB			75°F EDB			70°F EDB			65°F EDB		
		TMBH	SMBH	kW	TMBH	SMBH	kW	TMBH	SMBH	kW	TMBH	SMBH	kW	TMBH	SMBH	kW	TMBH	SMBH	kW	TMBH	SMBH	kW
5,000	77	403	232	31	402	204	31	402	176	31	402	149	31	-	-	-	-	-	-	-	-	-
	72	359	252	31	358	224	31	358	196	31	357	168	31	357	140	31	-	-	-	-	-	-
	67	-	-	-	-	-	-	-	-	-	-	-	-	-	-	-	-	-	-	-	-	-
	62	-	-	-	-	-	-	-	-	-	-	-	-	-	-	-	-	-	-	-	-	-
	57	-	-	-	-	-	-	-	-	-	-	-	-	-	-	-	-	-	-	-	-	-
6,750	77	436	270	32	436	233	32	435	195	32	434	157	32	-	-	-	-	-	-	-	-	-
	72	391	300	31	391	263	31	390	225	31	389	188	31	388	150	31	-	-	-	-	-	-
	67	348	326	31	345	288	31	344	251	31	343	213	31	342	176	31	340	138	31	-	-	-
	62	342	342	31	321	321	30	-	-	-	312	250	30	311	213	30	310	176	30	-	-	-
	57	347	347	31	328	328	30	-	-	-	-	-	-	-	-	-	-	-	-	-	-	-
8,500	77	-	-	-	-	-	-	-	-	-	-	-	-	-	-	-	-	-	-	-	-	-
	72	413	346	32	411	299	32	410	252	32	408	204	32	407	157	32	-	-	-	-	-	-
	67	378	378	31	367	335	31	364	288	31	362	241	31	360	193	31	359	146	31	-	-	-
	62	382	382	31	359	359	31	336	335	31	331	288	31	329	241	31	328	194	31	327	147	31
	57	386	386	31	364	364	31	343	343	31	322	322	30	-	-	-	-	-	-	-	-	-
10,250	77	-	-	-	-	-	-	-	-	-	-	-	-	-	-	-	-	-	-	-	-	-
	72	430	391	32	426	334	32	423	277	32	421	220	32	418	163	32	-	-	-	-	-	-
	67	411	411	32	385	381	31	378	324	31	375	267	31	373	210	31	370	152	31	-	-	-
	62	414	414	32	389	389	31	364	364	31	346	325	31	343	268	31	340	211	31	339	154	31
	57	418	418	32	394	394	31	370	370	31	347	347	31	324	324	30	316	273	30	314	216	30
12,000	77	-	-	-	-	-	-	-	-	-	-	-	-	-	-	-	-	-	-	-	-	-
	72	-	-	-	-	-	-	-	-	-	-	-	-	427	169	32	-	-	-	-	-	-
	67	-	-	-	409	409	32	390	359	32	385	292	32	382	225	31	379	158	31	-	-	-
	62	-	-	-	413	413	32	386	386	31	360	360	31	353	294	31	350	227	31	347	161	31
	57	-	-	-	418	418	32	392	392	31	367	367	31	343	343	31	327	299	30	323	233	30

**Table 37: 30 ton high capacity - 105°F ambient air temperature**

CFM	EWB (°F)	95°F EDB			90°F EDB			85°F EDB			80°F EDB			75°F EDB			70°F EDB			65°F EDB		
		TMBH	SMBH	kW	TMBH	SMBH	kW	TMBH	SMBH	kW	TMBH	SMBH	kW	TMBH	SMBH	kW	TMBH	SMBH	kW	TMBH	SMBH	kW
5,000	77	379	218	35	378	191	35	378	163	35	377	135	35	-	-	-	-	-	-	-	-	-
	72	338	239	34	337	212	34	337	184	34	336	156	34	336	128	34	-	-	-	-	-	-
	67	296	255	34	295	228	34	294	200	34	294	172	34	293	145	34	292	117	34	-	-	-
	62	-	-	-	-	-	-	-	-	-	-	-	-	-	-	-	-	-	-	-	-	-
	57	-	-	-	-	-	-	-	-	-	-	-	-	-	-	-	-	-	-	-	-	-
6,750	77	-	-	-	-	-	-	-	-	-	-	-	-	-	-	-	-	-	-	-	-	-
	72	368	287	35	367	250	35	366	213	35	365	175	35	364	138	35	-	-	-	-	-	-
	67	327	314	34	324	276	34	323	239	34	322	202	34	321	165	34	320	127	34	-	-	-
	62	326	326	34	307	307	34	295	278	34	294	240	34	293	203	34	292	166	34	286	128	34
	57	328	328	34	309	309	34	-	-	-	-	-	-	-	-	-	-	-	-	-	-	-
8,500	77	-	-	-	-	-	-	-	-	-	-	-	-	-	-	-	-	-	-	-	-	-
	72	388	333	35	386	286	35	385	239	35	383	192	35	381	145	35	-	-	-	-	-	-
	67	359	359	35	344	323	35	341	276	35	340	229	35	338	182	35	336	135	35	-	-	-
	62	364	364	35	342	342	34	320	320	34	312	278	34	310	231	34	309	184	34	308	137	34
	57	365	365	35	344	344	34	323	323	34	302	302	34	-	-	-	-	-	-	-	-	-
10,250	77	-	-	-	-	-	-	-	-	-	-	-	-	-	-	-	-	-	-	-	-	-
	72	-	-	-	-	-	-	397	265	35	395	208	35	393	151	35	-	-	-	-	-	-
	67	390	390	35	365	365	35	355	312	35	352	255	35	350	198	35	347	141	35	-	-	-
	62	394	394	35	370	370	35	346	346	35	326	315	34	322	258	34	320	201	34	318	144	34
	57	395	395	35	372	372	35	348	348	35	326	326	34	304	304	34	293	258	34	290	201	34
12,000	77	-	-	-	-	-	-	-	-	-	-	-	-	-	-	-	-	-	-	-	-	-
	72	-	-	-	-	-	-	-	-	-	-	-	-	-	-	-	-	-	-	-	-	-
	67	-	-	-	388	388	35	366	348	35	361	281	35	358	214	35	355	147	35	-	-	-
	62	-	-	-	393	393	35	367	367	35	342	342	35	332	284	34	328	217	34	326	151	34
	57	-	-	-	394	394	35	369	369	35	345	345	35	321	321	34	302	284	34	298	218	34

**Table 38: 30 ton high capacity - 115°F ambient air temperature**

CFM	EWB (°F)	95°F EDB			90°F EDB			85°F EDB			80°F EDB			75°F EDB			70°F EDB			65°F EDB		
		TMBH	SMBH	kW	TMBH	SMBH	kW	TMBH	SMBH	kW	TMBH	SMBH	kW	TMBH	SMBH	kW	TMBH	SMBH	kW	TMBH	SMBH	kW
5,000	77	353	204	39	353	176	39	352	149	39	351	120	39	-	-	-	-	-	-	-	-	-
	72	315	227	38	315	199	38	315	172	38	314	144	38	313	116	38	-	-	-	-	-	-
	67	281	249	38	280	222	38	280	194	38	280	167	38	279	139	38	278	111	38	-	-	-
	62	-	-	-	-	-	-	-	-	-	-	-	-	-	-	-	-	-	-	-	-	-
	57	-	-	-	-	-	-	-	-	-	-	-	-	-	-	-	-	-	-	-	-	-
6,750	77	-	-	-	-	-	-	-	-	-	-	-	-	-	-	-	-	-	-	-	-	-
	72	343	274	39	342	237	39	341	200	39	340	163	39	339	125	39	-	-	-	-	-	-
	67	310	307	38	307	270	38	306	233	38	305	196	38	304	159	38	303	121	38	-	-	-
	62	308	308	38	290	290	38	275	266	38	273	229	38	272	192	38	271	155	38	266	116	38
	57	308	308	38	289	289	38	271	271	38	-	-	-	-	-	-	-	-	-	-	-	-
8,500	77	-	-	-	-	-	-	-	-	-	-	-	-	-	-	-	-	-	-	-	-	-
	72	361	320	39	359	273	39	358	227	39	356	179	39	354	132	39	-	-	-	-	-	-
	67	344	344	39	326	317	39	323	270	39	321	223	39	320	176	39	318	129	39	-	-	-
	62	344	344	39	322	322	39	302	302	38	290	266	38	288	219	38	286	173	38	285	125	38
	57	343	343	39	322	322	39	301	301	38	281	281	38	261	261	38	256	215	38	255	169	37
10,250	77	-	-	-	-	-	-	-	-	-	-	-	-	-	-	-	-	-	-	-	-	-
	72	-	-	-	-	-	-	-	-	-	-	-	-	-	-	-	-	-	-	-	-	-
	67	-	-	-	349	349	39	336	306	39	332	249	39	330	192	39	328	135	39	-	-	-
	62	-	-	-	349	349	39	326	326	39	304	302	38	299	246	38	297	189	38	295	133	38
	57	-	-	-	348	348	39	325	325	39	303	303	38	281	281	38	267	242	38	265	186	38
12,000	77	-	-	-	-	-	-	-	-	-	-	-	-	-	-	-	-	-	-	-	-	-
	72	-	-	-	-	-	-	-	-	-	-	-	-	-	-	-	-	-	-	-	-	-
	67	-	-	-	-	-	-	347	341	39	340	274	39	338	208	39	335	141	39	-	-	-
	62	-	-	-	-	-	-	345	345	39	321	321	39	307	272	38	304	205	38	301	139	38
	57	-	-	-	-	-	-	345	345	39	321	321	39	298	298	38	277	269	38	272	202	38

**Table 39: 30 ton high capacity - 125°F ambient air temperature**

CFM	EWB (°F)	95°F EDB			90°F EDB			85°F EDB			80°F EDB			75°F EDB			70°F EDB			65°F EDB		
		TMBH	SMBH	kW	TMBH	SMBH	kW	TMBH	SMBH	kW	TMBH	SMBH	kW	TMBH	SMBH	kW	TMBH	SMBH	kW	TMBH	SMBH	kW
5,000	77	-	-	-	-	-	-	-	-	-	-	-	-	-	-	-	-	-	-	-	-	-
	72	-	-	-	-	-	-	-	-	-	-	-	-	-	-	-	-	-	-	-	-	-
	67	-	-	-	-	-	-	-	-	-	-	-	-	-	-	-	-	-	-	-	-	-
	62	-	-	-	-	-	-	-	-	-	-	-	-	-	-	-	-	-	-	-	-	-
	57	-	-	-	-	-	-	-	-	-	-	-	-	-	-	-	-	-	-	-	-	-
6,750	77	-	-	-	-	-	-	-	-	-	-	-	-	-	-	-	-	-	-	-	-	-
	72	-	-	-	-	-	-	-	-	-	-	-	-	-	-	-	-	-	-	-	-	-
	67	-	-	-	-	-	-	-	-	-	-	-	-	-	-	-	-	-	-	-	-	-
	62	-	-	-	-	-	-	-	-	-	-	-	-	-	-	-	-	-	-	-	-	-
	57	-	-	-	-	-	-	-	-	-	232	232	42	-	-	-	-	-	-	-	-	-
8,500	77	-	-	-	-	-	-	-	-	-	-	-	-	-	-	-	-	-	-	-	-	-
	72	-	-	-	-	-	-	-	-	-	-	-	-	-	-	-	-	-	-	-	-	-
	67	-	-	-	-	-	-	-	-	-	-	-	-	-	-	-	-	-	-	-	-	-
	62	-	-	-	-	-	-	-	-	-	-	-	-	-	-	-	-	-	-	-	-	-
	57	-	-	-	-	-	-	-	-	-	-	-	-	-	-	-	230	199	42	229	152	42
10,250	77	-	-	-	-	-	-	-	-	-	-	-	-	-	-	-	-	-	-	-	-	-
	72	-	-	-	-	-	-	-	-	-	-	-	-	-	-	-	-	-	-	-	-	-
	67	-	-	-	-	-	-	-	-	-	-	-	-	-	-	-	-	-	-	-	-	-
	62	-	-	-	-	-	-	-	-	-	-	-	-	-	-	-	-	-	-	-	-	-
	57	-	-	-	-	-	-	-	-	-	-	-	-	-	-	-	-	-	-	-	-	-
12,000	77	-	-	-	-	-	-	-	-	-	-	-	-	-	-	-	-	-	-	-	-	-
	72	-	-	-	-	-	-	-	-	-	-	-	-	-	-	-	-	-	-	-	-	-
	67	-	-	-	-	-	-	-	-	-	-	-	-	-	-	-	-	-	-	-	-	-
	62	-	-	-	-	-	-	-	-	-	-	-	-	-	-	-	-	-	-	-	-	-
	57	-	-	-	-	-	-	-	-	-	-	-	-	-	-	-	-	-	-	-	-	-

**Notes:**  
 Rated performance is at sea level. Cooling capacities are gross cooling capacities.  
 CFM = airflow, EWB = entering wet bulb air, EDB = entering dry bulb air, TMBH = total cooling capacity (MBH)  
 SMBH = sensible cooling capacity (MBH), kW = total input

## Cooling performance data 40 ton standard efficiency

**Table 40: 40 ton standard efficiency - 75°F ambient air temperature**

CFM	EWB (°F)	95°F EDB			90°F EDB			85°F EDB			80°F EDB			75°F EDB			70°F EDB			65°F EDB		
		TMBH	SMBH	kW	TMBH	SMBH	kW	TMBH	SMBH	kW	TMBH	SMBH	kW	TMBH	SMBH	kW	TMBH	SMBH	kW	TMBH	SMBH	kW
8,000	77	560	322	33	560	279	33	559	235	33	559	191	33	-	-	-	-	-	-	-	-	-
	72	509	366	33	509	323	33	509	280	33	508	236	33	508	192	33	-	-	-	-	-	-
	67	463	409	32	462	366	32	462	323	32	462	280	32	462	236	32	461	193	32	-	-	-
	62	-	-	-	-	-	-	-	-	-	-	-	-	-	-	-	-	-	-	-	-	-
	57	-	-	-	-	-	-	-	-	-	-	-	-	-	-	-	-	-	-	-	-	-
11,000	77	611	391	34	609	331	34	608	271	34	606	210	34	-	-	-	-	-	-	-	-	-
	72	559	452	33	558	392	33	557	333	33	555	272	33	554	212	33	-	-	-	-	-	-
	67	518	511	33	511	452	33	509	393	33	508	333	33	506	273	33	506	214	33	-	-	-
	62	515	515	33	489	489	32	468	452	32	463	392	32	462	333	32	461	273	32	460	214	32
	57	513	513	33	488	488	32	462	462	32	-	-	-	-	-	-	-	-	-	-	-	-
14,000	77	-	-	-	-	-	-	-	-	-	-	-	-	-	-	-	-	-	-	-	-	-
	72	594	533	33	589	457	33	585	380	33	584	304	33	581	227	33	-	-	-	-	-	-
	67	574	574	33	547	533	33	539	458	33	535	381	33	534	306	33	532	229	33	-	-	-
	62	572	572	33	542	542	33	513	513	33	494	458	32	489	382	32	487	306	32	485	229	32
	57	571	571	33	541	541	33	512	512	33	483	483	32	455	454	32	446	381	32	444	305	32
17,000	77	-	-	-	-	-	-	-	-	-	-	-	-	-	-	-	-	-	-	-	-	-
	72	623	609	34	612	519	34	605	426	34	604	334	34	600	241	34	-	-	-	-	-	-
	67	619	619	34	585	585	33	563	520	33	555	427	33	553	335	33	550	242	33	-	-	-
	62	617	617	34	584	584	33	551	551	33	520	517	33	508	428	32	505	336	32	502	243	32
	57	616	616	34	583	583	33	550	550	33	519	519	33	487	487	32	465	427	32	461	335	32
20,000	77	-	-	-	-	-	-	-	-	-	-	-	-	-	-	-	-	-	-	-	-	-
	72	-	-	-	630	579	34	621	471	34	617	362	34	613	253	34	-	-	-	-	-	-
	67	-	-	-	618	618	34	584	576	33	570	472	33	566	364	33	562	255	33	-	-	-
	62	-	-	-	617	617	34	582	582	33	546	546	33	524	472	33	518	365	33	515	255	33
	57	-	-	-	616	616	34	581	581	33	545	545	33	512	512	33	482	470	32	473	364	32

**Table 41: 40 ton standard efficiency - 85°F ambient air temperature**

CFM	EWB (°F)	95°F EDB			90°F EDB			85°F EDB			80°F EDB			75°F EDB			70°F EDB			65°F EDB		
		TMBH	SMBH	kW	TMBH	SMBH	kW	TMBH	SMBH	kW	TMBH	SMBH	kW	TMBH	SMBH	kW	TMBH	SMBH	kW	TMBH	SMBH	kW
8,000	77	536	310	36	535	267	36	534	223	36	534	179	36	-	-	-	-	-	-	-	-	-
	72	488	356	36	488	313	36	488	270	36	487	226	36	487	182	36	-	-	-	-	-	-
	67	449	403	35	448	360	35	447	317	35	447	274	35	446	230	35	446	187	35	-	-	-
	62	-	-	-	-	-	-	-	-	-	-	-	-	-	-	-	-	-	-	-	-	-
	57	-	-	-	-	-	-	-	-	-	-	-	-	-	-	-	-	-	-	-	-	-
11,000	77	583	379	37	580	318	37	580	259	37	577	198	37	-	-	-	-	-	-	-	-	-
	72	535	441	36	533	381	36	531	321	36	531	261	36	528	201	36	-	-	-	-	-	-
	67	503	501	36	493	445	36	490	385	35	489	326	35	487	266	35	486	206	35	-	-	-
	62	497	497	36	472	472	35	449	440	35	443	381	35	441	322	35	440	262	35	439	202	35
	57	494	494	36	469	469	35	444	444	35	-	-	-	-	-	-	-	-	-	-	-	-
14,000	77	-	-	-	-	-	-	-	-	-	-	-	-	-	-	-	-	-	-	-	-	-
	72	568	521	36	562	445	36	558	369	36	557	293	36	554	216	36	-	-	-	-	-	-
	67	556	556	36	528	523	36	518	449	36	513	373	36	512	297	36	510	220	36	-	-	-
	62	552	552	36	522	522	36	494	494	36	472	446	35	465	369	35	464	294	35	462	217	35
	57	549	549	36	520	520	36	491	491	36	463	463	35	435	435	35	423	367	35	420	292	35
17,000	77	-	-	-	-	-	-	-	-	-	-	-	-	-	-	-	-	-	-	-	-	-
	72	-	-	-	583	507	37	577	414	36	575	322	36	571	229	36	-	-	-	-	-	-
	67	-	-	-	566	566	36	540	510	36	531	418	36	529	326	36	526	233	36	-	-	-
	62	-	-	-	562	562	36	530	530	36	498	498	36	484	415	35	480	324	35	477	231	35
	57	592	592	37	559	559	36	527	527	36	496	496	36	465	465	35	441	413	35	436	322	35
20,000	77	-	-	-	-	-	-	-	-	-	-	-	-	-	-	-	-	-	-	-	-	-
	72	-	-	-	-	-	-	591	459	37	586	350	37	582	240	37	-	-	-	-	-	-
	67	-	-	-	596	596	37	560	560	36	545	462	36	540	354	36	536	244	36	-	-	-
	62	-	-	-	592	592	37	557	557	36	523	523	36	499	460	36	492	352	36	488	243	35
	57	-	-	-	590	590	37	555	555	36	521	521	36	489	489	35	458	454	35	448	350	35

**Table 42: 40 ton standard efficiency - 95°F ambient air temperature**

CFM	EWB (°F)	95°F EDB			90°F EDB			85°F EDB			80°F EDB			75°F EDB			70°F EDB			65°F EDB		
		TMBH	SMBH	kW	TMBH	SMBH	kW	TMBH	SMBH	kW	TMBH	SMBH	kW	TMBH	SMBH	kW	TMBH	SMBH	kW	TMBH	SMBH	kW
8,000	77	510	298	40	509	254	40	508	211	40	508	167	40	-	-	-	-	-	-	-	-	-
	72	469	348	39	469	305	39	469	262	39	468	218	39	468	175	39	-	-	-	-	-	-
	67	435	398	39	433	355	39	433	312	39	433	269	39	431	225	38	431	182	38	-	-	-
	62	412	412	38	-	-	-	-	-	-	-	-	-	-	-	-	-	-	-	-	-	-
	57	404	404	38	-	-	-	-	-	-	-	-	-	-	-	-	-	-	-	-	-	-
11,000	77	-	-	-	-	-	-	-	-	-	548	185	40	-	-	-	-	-	-	-	-	-
	72	512	432	39	510	372	39	508	312	39	507	253	39	505	192	39	-	-	-	-	-	-
	67	488	488	39	475	438	39	471	379	39	468	319	39	468	259	39	466	199	39	-	-	-
	62	481	481	39	456	456	39	432	430	39	424	373	38	421	313	38	420	253	38	418	193	38
	57	474	474	39	449	449	39	424	424	39	400	400	38	-	-	-	-	-	-	-	-	-
14,000	77	-	-	-	-	-	-	-	-	-	-	-	-	-	-	-	-	-	-	-	-	-
	72	543	511	40	536	435	40	532	359	40	531	283	40	528	206	40	-	-	-	-	-	-
	67	539	539	40	510	510	39	497	442	39	491	365	39	490	289	39	487	213	39	-	-	-
	62	533	533	40	504	504	39	475	475	39	451	436	39	444	360	39	442	284	39	440	208	39
	57	526	526	40	497	497	39	469	469	39	441	441	39	414	414	38	398	353	38	396	278	38
17,000	77	-	-	-	-	-	-	-	-	-	-	-	-	-	-	-	-	-	-	-	-	-
	72	-	-	-	555	496	40	549	404	40	546	311	40	542	218	40	-	-	-	-	-	-
	67	-	-	-	546	546	40	517	500	39	508	410	39	505	317	39	501	224	39	-	-	-
	62	-	-	-	540	540	40	509	509	39	477	477	39	461	405	39	457	313	39	453	220	39
	57	-	-	-	535	535	40	503	503	39	472	472	39	442	442	39	417	399	38	410	307	38
20,000	77	-	-	-	-	-	-	-	-	-	-	-	-	-	-	-	-	-	-	-	-	-
	72	-	-	-	-	-	-	-	-	-	556	339	40	552	229	40	-	-	-	-	-	-
	67	-	-	-	-	-	-	540	540	40	521	453	39	514	344	39	510	235	39	-	-	-
	62	-	-	-	-	-	-	534	534	40	502	502	39	475	448	39	466	341	39	462	232	39
	57	-	-	-	-	-	-	529	529	40	496	496	39	465	465	39	434	434	39	421	335	38

**Table 43: 40 ton standard efficiency - 105°F ambient air temperature**

CFM	EWB (°F)	95°F EDB			90°F EDB			85°F EDB			80°F EDB			75°F EDB			70°F EDB			65°F EDB		
		TMBH	SMBH	kW	TMBH	SMBH	kW	TMBH	SMBH	kW	TMBH	SMBH	kW	TMBH	SMBH	kW	TMBH	SMBH	kW	TMBH	SMBH	kW
8,000	77	482	285	44	480	241	44	480	198	44	479	154	44	-	-	-	-	-	-	-	-	-
	72	439	331	43	439	288	43	437	244	43	437	201	43	437	157	43	-	-	-	-	-	-
	67	405	379	43	403	336	42	402	293	42	402	250	42	401	206	42	400	163	42	-	-	-
	62	388	388	42	368	368	42	359	329	42	358	286	42	358	243	42	357	200	42	356	156	42
	57	385	385	42	364	364	42	-	-	-	-	-	-	-	-	-	-	-	-	-	-	-
11,000	77	-	-	-	-	-	-	-	-	-	-	-	-	-	-	-	-	-	-	-	-	-
	72	480	415	43	477	355	43	474	295	43	474	235	43	472	175	43	-	-	-	-	-	-
	67	461	461	43	443	419	43	438	360	43	436	300	43	435	240	43	433	180	43	-	-	-
	62	455	455	43	430	430	43	406	406	43	394	354	42	391	294	42	390	235	42	388	175	42
	57	452	452	43	427	427	43	403	403	43	379	379	42	-	-	-	-	-	-	350	231	42
14,000	77	-	-	-	-	-	-	-	-	-	-	-	-	-	-	-	-	-	-	-	-	-
	72	-	-	-	501	418	44	497	342	44	495	265	44	492	188	44	-	-	-	-	-	-
	67	509	509	44	481	481	43	463	423	43	457	346	43	456	270	43	452	193	43	-	-	-
	62	504	504	44	476	476	43	448	448	43	421	416	43	412	342	43	410	266	43	407	189	43
	57	501	501	44	473	473	43	445	445	43	418	418	43	390	390	42	373	338	42	369	263	42
17,000	77	-	-	-	-	-	-	-	-	-	-	-	-	-	-	-	-	-	-	-	-	-
	72	-	-	-	-	-	-	513	387	44	509	294	44	505	201	44	-	-	-	-	-	-
	67	-	-	-	514	514	44	484	479	43	473	391	43	468	298	43	465	205	43	-	-	-
	62	-	-	-	509	509	44	479	479	43	449	449	43	429	387	43	423	295	43	419	202	43
	57	-	-	-	507	507	44	476	476	43	446	446	43	417	417	43	390	382	42	382	292	42
20,000	77	-	-	-	-	-	-	-	-	-	-	-	-	-	-	-	-	-	-	-	-	-
	72	-	-	-	-	-	-	-	-	-	-	-	-	515	212	44	-	-	-	-	-	-
	67	-	-	-	-	-	-	508	508	44	486	435	43	478	326	43	474	217	43	-	-	-
	62	-	-	-	-	-	-	504	504	44	472	472	43	443	429	43	433	322	43	429	213	43
	57	-	-	-	-	-	-	501	501	44	469	469	43	438	438	43	408	408	43	392	320	42

**Table 44: 40 ton standard efficiency - 115°F ambient air temperature**

CFM	EWB (°F)	95°F EDB			90°F EDB			85°F EDB			80°F EDB			75°F EDB			70°F EDB			65°F EDB		
		TMBH	SMBH	kW	TMBH	SMBH	kW	TMBH	SMBH	kW	TMBH	SMBH	kW	TMBH	SMBH	kW	TMBH	SMBH	kW	TMBH	SMBH	kW
8,000	77	451	272	48	450	228	48	449	184	48	448	140	48	-	-	-	-	-	-	-	-	-
	72	408	315	48	408	272	48	407	228	48	407	185	48	405	141	48	-	-	-	-	-	-
	67	372	358	47	369	314	47	368	271	47	367	228	47	367	185	47	365	141	47	-	-	-
	62	365	365	47	345	345	47	333	313	47	331	270	47	330	227	47	329	183	47	341	144	47
	57	364	364	47	344	344	47	-	-	-	-	-	-	-	-	-	-	-	-	-	-	-
11,000	77	-	-	-	-	-	-	-	-	-	-	-	-	-	-	-	-	-	-	-	-	-
	72	447	398	48	443	338	48	441	279	48	439	219	48	437	158	48	-	-	-	-	-	-
	67	430	430	48	408	398	48	402	338	47	399	278	47	398	219	47	396	158	47	-	-	-
	62	429	429	48	404	404	47	380	380	47	365	337	47	360	277	47	360	218	47	358	158	47
	57	428	428	48	403	403	47	379	379	47	356	356	47	333	332	47	324	275	47	323	216	46
14,000	77	-	-	-	-	-	-	-	-	-	-	-	-	-	-	-	-	-	-	-	-	-
	72	-	-	-	-	-	-	461	325	48	458	249	48	455	172	48	-	-	-	-	-	-
	67	-	-	-	448	448	48	426	401	48	420	325	48	416	249	48	413	172	48	-	-	-
	62	-	-	-	447	447	48	419	419	48	392	392	47	381	324	47	377	248	47	374	172	47
	57	-	-	-	446	446	48	418	418	48	391	391	47	365	365	47	345	323	47	340	247	47
17,000	77	-	-	-	-	-	-	-	-	-	-	-	-	-	-	-	-	-	-	-	-	-
	72	-	-	-	-	-	-	-	-	-	-	-	-	467	184	48	-	-	-	-	-	-
	67	-	-	-	-	-	-	449	449	48	435	370	48	429	278	48	425	185	48	-	-	-
	62	-	-	-	-	-	-	448	448	48	419	419	48	396	369	47	389	277	47	386	184	47
	57	-	-	-	-	-	-	448	448	48	419	419	48	390	390	47	363	362	47	352	276	47
20,000	77	-	-	-	-	-	-	-	-	-	-	-	-	-	-	-	-	-	-	-	-	-
	72	-	-	-	-	-	-	-	-	-	-	-	-	-	-	-	-	-	-	-	-	-
	67	-	-	-	-	-	-	-	-	-	447	413	48	439	305	48	433	196	48	-	-	-
	62	-	-	-	-	-	-	-	-	-	441	441	48	410	408	47	399	305	47	393	195	47
	57	-	-	-	-	-	-	-	-	-	440	440	48	410	410	47	380	380	47	361	303	47

**Table 45: 40 ton standard efficiency - 125°F ambient air temperature**

CFM	EWB (°F)	95°F EDB			90°F EDB			85°F EDB			80°F EDB			75°F EDB			70°F EDB			65°F EDB		
		TMBH	SMBH	kW	TMBH	SMBH	kW	TMBH	SMBH	kW	TMBH	SMBH	kW	TMBH	SMBH	kW	TMBH	SMBH	kW	TMBH	SMBH	kW
8,000	77	-	-	-	-	-	-	-	-	-	-	-	-	-	-	-	-	-	-	-	-	-
	72	377	300	53	376	257	53	375	214	53	375	170	53	373	126	53	-	-	-	-	-	-
	67	345	342	52	340	299	52	338	256	52	337	213	52	337	169	52	335	125	52	-	-	-
	62	343	343	52	323	323	52	306	298	52	303	254	52	301	211	52	301	168	52	310	127	52
	57	342	342	52	322	322	52	302	302	52	-	-	-	-	-	-	-	-	-	-	-	-
11,000	77	-	-	-	-	-	-	-	-	-	-	-	-	-	-	-	-	-	-	-	-	-
	72	-	-	-	407	323	53	406	263	53	403	203	53	401	142	53	-	-	-	-	-	-
	67	403	403	53	379	378	53	369	322	53	366	263	53	364	203	53	362	142	53	-	-	-
	62	402	402	53	378	378	53	354	354	52	334	321	52	329	261	52	328	201	52	325	141	52
	57	401	401	53	377	377	53	353	353	52	330	330	52	307	307	52	296	259	52	294	200	52
14,000	77	-	-	-	-	-	-	-	-	-	-	-	-	-	-	-	-	-	-	-	-	-
	72	-	-	-	-	-	-	-	-	-	-	-	-	417	156	53	-	-	-	-	-	-
	67	-	-	-	-	-	-	392	383	53	385	309	53	381	233	53	378	156	53	-	-	-
	62	-	-	-	-	-	-	390	390	53	364	364	53	348	308	52	344	232	52	341	155	52
	57	-	-	-	-	-	-	389	389	53	363	363	53	338	338	52	315	305	52	309	230	52
17,000	77	-	-	-	-	-	-	-	-	-	-	-	-	-	-	-	-	-	-	-	-	-
	72	-	-	-	-	-	-	-	-	-	-	-	-	-	-	-	-	-	-	-	-	-
	67	-	-	-	-	-	-	-	-	-	399	354	53	393	261	53	388	168	53	-	-	-
	62	-	-	-	-	-	-	-	-	-	389	389	53	363	351	53	355	260	52	350	167	52
	57	-	-	-	-	-	-	-	-	-	388	388	53	361	361	52	333	333	52	320	259	52
20,000	77	-	-	-	-	-	-	-	-	-	-	-	-	-	-	-	-	-	-	-	-	-
	72	-	-	-	-	-	-	-	-	-	-	-	-	-	-	-	-	-	-	-	-	-
	67	-	-	-	-	-	-	-	-	-	410	395	53	401	289	53	395	179	53	-	-	-
	62	-	-	-	-	-	-	-	-	-	408	408	53	377	377	53	363	288	52	357	178	52
	57	-	-	-	-	-	-	-	-	-	407	407	53	377	377	53	349	349	52	328	286	52

**Notes:**  
 Rated performance is at sea level. Cooling capacities are gross cooling capacities.  
 CFM = airflow, EWB = entering wet bulb air, EDB = entering dry bulb air, TMBH = total cooling capacity (MBH)  
 SMBH = sensible cooling capacity (MBH), kW = total input

Cooling performance data 40 ton high efficiency

Table 46: 40 ton high efficiency - 75°F ambient air temperature

CFM	EWB (°F)	95°F EDB			90°F EDB			85°F EDB			80°F EDB			75°F EDB			70°F EDB			65°F EDB		
		TMBH	SMBH	kW	TMBH	SMBH	kW	TMBH	SMBH	kW	TMBH	SMBH	kW	TMBH	SMBH	kW	TMBH	SMBH	kW	TMBH	SMBH	kW
8,000	77	547	317	31	547	274	31	545	230	31	545	186	31	-	-	-	-	-	-	-	-	-
	72	496	361	31	496	318	31	496	274	31	495	231	31	495	187	31	-	-	-	-	-	-
	67	451	403	31	450	360	31	450	317	31	450	274	31	449	231	31	449	187	31	-	-	-
	62	-	-	-	-	-	-	-	-	-	-	-	-	-	-	-	-	-	-	-	-	-
	57	-	-	-	-	-	-	-	-	-	-	-	-	-	-	-	-	-	-	-	-	-
11,000	77	596	386	31	594	326	31	593	266	31	591	205	31	-	-	-	-	-	-	-	-	-
	72	545	447	31	543	387	31	542	327	31	541	267	31	539	207	31	-	-	-	-	-	-
	67	506	505	31	497	447	31	495	387	31	494	328	31	492	268	31	491	207	31	-	-	-
	62	504	504	31	478	478	31	455	446	31	450	386	31	448	327	31	447	267	31	446	207	31
	57	503	503	31	477	477	31	452	452	31	-	-	-	-	-	-	-	-	-	-	-	-
14,000	77	-	-	-	-	-	-	-	-	-	-	-	-	-	-	-	-	-	-	-	-	-
	72	579	528	31	573	452	31	569	375	31	569	299	31	566	222	31	-	-	-	-	-	-
	67	562	562	31	534	527	31	524	452	31	520	376	31	519	300	31	516	223	31	-	-	-
	62	561	561	31	531	531	31	501	501	31	480	452	31	474	375	31	472	300	31	470	223	31
	57	560	560	31	530	530	31	500	500	31	472	472	31	444	444	31	432	374	31	429	298	31
17,000	77	-	-	-	-	-	-	-	-	-	-	-	-	-	-	-	-	-	-	-	-	-
	72	-	-	-	596	514	31	589	421	31	587	329	31	584	235	31	-	-	-	-	-	-
	67	-	-	-	573	573	31	548	515	31	539	422	31	537	330	31	534	236	31	-	-	-
	62	605	605	31	572	572	31	539	539	31	507	507	31	493	422	31	490	330	31	487	237	31
	57	604	604	31	571	571	31	538	538	31	506	506	31	475	475	31	450	421	31	446	329	31
20,000	77	-	-	-	-	-	-	-	-	-	-	-	-	-	-	-	-	-	-	-	-	-
	72	-	-	-	-	-	-	604	466	31	600	357	31	595	247	31	-	-	-	-	-	-
	67	-	-	-	605	605	31	569	567	31	554	467	31	549	358	31	545	248	31	-	-	-
	62	-	-	-	604	604	31	567	567	31	533	533	31	508	466	31	502	358	31	498	249	31
	57	-	-	-	603	603	31	567	567	31	532	532	31	499	499	31	467	463	31	458	358	31

Table 47: 40 ton high efficiency - 85°F ambient air temperature

CFM	EWB (°F)	95°F EDB			90°F EDB			85°F EDB			80°F EDB			75°F EDB			70°F EDB			65°F EDB		
		TMBH	SMBH	kW	TMBH	SMBH	kW	TMBH	SMBH	kW	TMBH	SMBH	kW	TMBH	SMBH	kW	TMBH	SMBH	kW	TMBH	SMBH	kW
8,000	77	523	306	34	523	263	34	522	219	34	522	175	34	-	-	-	-	-	-	-	-	-
	72	477	352	34	477	309	34	477	266	34	476	222	34	476	178	34	-	-	-	-	-	-
	67	440	401	34	439	358	34	439	315	34	439	272	34	438	228	34	437	184	34	-	-	-
	62	417	417	34	-	-	-	-	-	-	-	-	-	-	-	-	-	-	-	-	-	-
	57	413	413	34	-	-	-	-	-	-	-	-	-	-	-	-	-	-	-	-	-	-
11,000	77	-	-	-	-	-	-	-	-	-	564	193	35	-	-	-	-	-	-	-	-	-
	72	522	437	34	520	377	34	518	317	34	518	257	34	516	197	34	-	-	-	-	-	-
	67	495	495	34	482	442	34	479	382	34	477	322	34	476	263	34	474	202	34	-	-	-
	62	489	489	34	463	463	34	438	436	34	431	377	34	429	317	34	428	257	34	426	197	34
	57	485	485	34	459	459	34	434	434	34	410	410	34	-	-	-	-	-	-	-	-	-
14,000	77	-	-	-	-	-	-	-	-	-	-	-	-	-	-	-	-	-	-	-	-	-
	72	555	517	35	548	441	35	544	364	35	543	288	35	540	211	35	-	-	-	-	-	-
	67	547	547	35	518	518	34	506	446	34	501	369	34	500	294	34	497	217	34	-	-	-
	62	542	542	34	512	512	34	484	484	34	460	441	34	453	365	34	451	289	34	449	212	34
	57	539	539	34	509	509	34	481	481	34	452	452	34	425	425	34	410	361	34	408	286	34
17,000	77	-	-	-	-	-	-	-	-	-	-	-	-	-	-	-	-	-	-	-	-	-
	72	-	-	-	569	503	35	562	410	35	560	317	35	556	224	35	-	-	-	-	-	-
	67	-	-	-	556	556	35	528	507	34	519	415	34	516	322	34	512	229	34	-	-	-
	62	-	-	-	551	551	35	519	519	34	487	487	34	470	411	34	467	319	34	463	225	34
	57	-	-	-	548	548	35	516	516	34	484	484	34	454	454	34	428	407	34	423	316	34
20,000	77	-	-	-	-	-	-	-	-	-	-	-	-	-	-	-	-	-	-	-	-	-
	72	-	-	-	-	-	-	-	-	-	571	345	35	566	235	35	-	-	-	-	-	-
	67	-	-	-	-	-	-	550	550	35	532	459	34	526	350	34	522	240	34	-	-	-
	62	-	-	-	-	-	-	545	545	35	512	512	34	485	455	34	477	346	34	473	237	34
	57	-	-	-	-	-	-	543	543	35	509	509	34	477	477	34	445	445	34	433	344	34

**Table 48: 40 ton high efficiency - 95°F ambient air temperature**

CFM	EWB (°F)	95°F EDB			90°F EDB			85°F EDB			80°F EDB			75°F EDB			70°F EDB			65°F EDB		
		TMBH	SMBH	kW	TMBH	SMBH	kW	TMBH	SMBH	kW	TMBH	SMBH	kW	TMBH	SMBH	kW	TMBH	SMBH	kW	TMBH	SMBH	kW
8,000	77	498	294	38	497	251	38	497	207	38	496	163	38	-	-	-	-	-	-	-	-	-
	72	461	347	38	461	304	38	461	261	38	460	217	38	459	173	38	-	-	-	-	-	-
	67	430	400	38	428	356	38	428	313	38	428	270	38	427	227	38	426	183	38	-	-	-
	62	407	407	37	-	-	-	-	-	-	-	-	-	-	-	-	-	-	-	377	173	37
	57	396	396	37	-	-	-	-	-	-	-	-	-	-	-	-	-	-	-	-	-	-
11,000	77	-	-	-	-	-	-	-	-	-	-	-	-	-	-	-	-	-	-	-	-	-
	72	502	430	38	500	370	38	498	310	38	497	250	38	495	190	38	-	-	-	-	-	-
	67	484	484	38	468	439	38	464	379	38	461	319	38	461	259	38	459	199	38	-	-	-
	62	475	475	38	450	450	38	425	425	38	415	371	38	412	310	38	411	251	38	410	191	37
	57	466	466	38	440	440	38	416	416	38	391	391	37	-	-	-	-	-	-	-	-	-
14,000	77	-	-	-	-	-	-	-	-	-	-	-	-	-	-	-	-	-	-	-	-	-
	72	533	509	38	525	433	38	521	357	38	519	280	38	516	203	38	-	-	-	-	-	-
	67	533	533	38	504	504	38	488	441	38	483	365	38	481	289	38	479	212	38	-	-	-
	62	525	525	38	496	496	38	468	468	38	442	433	38	434	357	38	432	282	38	429	205	38
	57	517	517	38	488	488	38	459	459	38	432	432	38	405	405	38	387	348	37	384	273	37
17,000	77	-	-	-	-	-	-	-	-	-	-	-	-	-	-	-	-	-	-	-	-	-
	72	-	-	-	-	-	-	537	402	38	533	308	38	529	215	38	-	-	-	-	-	-
	67	-	-	-	539	539	38	509	499	38	499	409	38	494	316	38	491	223	38	-	-	-
	62	-	-	-	531	531	38	499	499	38	469	469	38	450	403	38	445	310	38	441	217	38
	57	-	-	-	524	524	38	492	492	38	461	461	38	432	432	38	405	394	38	398	302	37
20,000	77	-	-	-	-	-	-	-	-	-	-	-	-	-	-	-	-	-	-	-	-	-
	72	-	-	-	-	-	-	-	-	-	-	-	539	226	38	-	-	-	-	-	-	-
	67	-	-	-	-	-	-	532	532	38	511	453	38	504	343	38	500	234	38	-	-	-
	62	-	-	-	-	-	-	525	525	38	493	493	38	464	446	38	455	338	38	451	228	38
	57	-	-	-	-	-	-	518	518	38	485	485	38	454	454	38	423	423	38	408	330	38

**Table 49: 40 ton high efficiency - 105°F ambient air temperature**

CFM	EWB (°F)	95°F EDB			90°F EDB			85°F EDB			80°F EDB			75°F EDB			70°F EDB			65°F EDB		
		TMBH	SMBH	kW	TMBH	SMBH	kW	TMBH	SMBH	kW	TMBH	SMBH	kW	TMBH	SMBH	kW	TMBH	SMBH	kW	TMBH	SMBH	kW
8,000	77	471	282	42	470	238	42	469	194	42	468	150	42	-	-	-	-	-	-	-	-	-
	72	430	328	42	429	285	42	428	241	42	428	198	42	427	154	42	-	-	-	-	-	-
	67	399	379	42	396	335	41	396	292	41	395	249	41	395	205	41	393	161	41	-	-	-
	62	383	383	41	362	362	41	352	327	41	350	283	41	350	240	41	349	197	41	361	157	41
	57	378	378	41	358	358	41	-	-	-	-	-	-	-	-	-	-	-	-	-	-	-
11,000	77	-	-	-	-	-	-	-	-	-	-	-	-	-	-	-	-	-	-	-	-	-
	72	469	412	42	466	352	42	464	292	42	463	232	42	461	171	42	-	-	-	-	-	-
	67	455	455	42	436	418	42	430	358	42	428	298	42	427	239	42	425	178	42	-	-	-
	62	448	448	42	423	423	42	399	399	42	385	351	41	381	291	41	381	232	41	379	171	41
	57	444	444	42	419	419	42	395	395	42	371	371	41	348	346	41	342	286	41	341	227	41
14,000	77	-	-	-	-	-	-	-	-	-	-	-	-	-	-	-	-	-	-	-	-	-
	72	-	-	-	489	415	42	486	339	42	483	262	42	479	185	42	-	-	-	-	-	-
	67	-	-	-	474	474	42	454	421	42	448	345	42	446	268	42	442	191	42	-	-	-
	62	-	-	-	467	467	42	440	440	42	412	411	42	402	338	42	400	262	42	396	185	42
	57	-	-	-	464	464	42	436	436	42	408	408	42	382	382	41	363	334	41	359	258	41
17,000	77	-	-	-	-	-	-	-	-	-	-	-	-	-	-	-	-	-	-	-	-	-
	72	-	-	-	-	-	-	-	-	-	-	-	493	197	42	-	-	-	-	-	-	-
	67	-	-	-	-	-	-	476	475	42	463	390	42	458	297	42	455	203	42	-	-	-
	62	-	-	-	-	-	-	469	469	42	440	440	42	418	384	42	412	291	42	409	198	42
	57	-	-	-	-	-	-	466	466	42	437	437	42	408	408	42	380	377	41	371	287	41
20,000	77	-	-	-	-	-	-	-	-	-	-	-	-	-	-	-	-	-	-	-	-	-
	72	-	-	-	-	-	-	-	-	-	-	-	-	-	-	-	-	-	-	-	-	-
	67	-	-	-	-	-	-	-	-	-	476	433	42	468	324	42	463	214	42	-	-	-
	62	-	-	-	-	-	-	-	-	-	462	462	42	432	425	42	421	319	42	417	209	42
	57	-	-	-	-	-	-	-	-	-	459	459	42	428	428	42	398	398	42	381	315	41

**Table 50: 40 ton high efficiency - 115°F ambient air temperature**

CFM	EWB (°F)	95°F EDB			90°F EDB			85°F EDB			80°F EDB			75°F EDB			70°F EDB			65°F EDB		
		TMBH	SMBH	kW	TMBH	SMBH	kW	TMBH	SMBH	kW	TMBH	SMBH	kW	TMBH	SMBH	kW	TMBH	SMBH	kW	TMBH	SMBH	kW
8,000	77	-	-	-	-	-	-	-	-	-	438	137	47	-	-	-	-	-	-	-	-	-
	72	399	312	46	399	269	46	397	225	46	397	181	46	396	137	46	-	-	-	-	-	-
	67	364	355	46	361	311	46	359	268	46	358	225	46	358	181	46	357	137	46	-	-	-
	62	359	359	46	339	339	46	325	310	46	323	266	46	322	223	46	322	180	46	320	136	45
	57	358	358	46	338	338	46	319	319	45	-	-	-	-	-	-	-	-	-	-	-	-
11,000	77	-	-	-	-	-	-	-	-	-	-	-	-	-	-	-	-	-	-	-	-	-
	72	436	395	47	431	335	47	430	275	47	428	215	47	425	154	47	-	-	-	-	-	-
	67	422	422	47	399	394	46	392	335	46	389	275	46	388	215	46	386	155	46	-	-	-
	62	421	421	46	397	397	46	373	373	46	356	334	46	352	274	46	351	214	46	348	154	46
	57	420	420	46	396	396	46	372	372	46	349	349	46	326	326	46	317	272	45	315	212	45
14,000	77	-	-	-	-	-	-	-	-	-	-	-	-	-	-	-	-	-	-	-	-	-
	72	-	-	-	-	-	-	-	-	-	-	-	-	443	168	47	-	-	-	-	-	-
	67	-	-	-	439	439	47	416	397	46	409	322	46	406	245	46	403	168	46	-	-	-
	62	-	-	-	438	438	47	410	410	46	384	384	46	371	321	46	367	244	46	364	168	46
	57	-	-	-	437	437	47	409	409	46	383	383	46	358	358	46	336	319	46	331	243	46
17,000	77	-	-	-	-	-	-	-	-	-	-	-	-	-	-	-	-	-	-	-	-	-
	72	-	-	-	-	-	-	-	-	-	-	-	-	-	-	-	-	-	-	-	-	-
	67	-	-	-	-	-	-	440	440	47	424	367	46	418	274	46	414	180	46	-	-	-
	62	-	-	-	-	-	-	439	439	47	410	410	46	386	365	46	379	273	46	375	180	46
	57	-	-	-	-	-	-	438	438	47	410	410	46	382	382	46	354	354	46	343	272	46
20,000	77	-	-	-	-	-	-	-	-	-	-	-	-	-	-	-	-	-	-	-	-	-
	72	-	-	-	-	-	-	-	-	-	-	-	-	-	-	-	-	-	-	-	-	-
	67	-	-	-	-	-	-	-	-	-	436	410	47	427	302	46	421	192	46	-	-	-
	62	-	-	-	-	-	-	-	-	-	431	431	47	401	401	46	388	301	46	382	191	46
	57	-	-	-	-	-	-	-	-	-	430	430	47	400	400	46	370	370	46	351	300	46

**Table 51: 40 ton high efficiency - 125°F ambient air temperature**

CFM	EWB (°F)	95°F EDB			90°F EDB			85°F EDB			80°F EDB			75°F EDB			70°F EDB			65°F EDB		
		TMBH	SMBH	kW	TMBH	SMBH	kW	TMBH	SMBH	kW	TMBH	SMBH	kW	TMBH	SMBH	kW	TMBH	SMBH	kW	TMBH	SMBH	kW
8,000	77	-	-	-	-	-	-	-	-	-	-	-	-	-	-	-	-	-	-	-	-	-
	72	369	297	51	368	254	51	367	211	51	366	167	51	365	123	51	-	-	-	-	-	-
	67	338	338	51	332	297	51	331	253	51	330	210	51	329	166	51	328	123	51	-	-	-
	62	337	337	51	317	317	51	300	295	51	296	252	51	295	208	50	295	165	50	294	121	50
	57	336	336	51	317	317	51	297	297	51	-	-	-	-	-	-	-	-	-	-	-	-
11,000	77	-	-	-	-	-	-	-	-	-	-	-	-	-	-	-	-	-	-	-	-	-
	72	-	-	-	-	-	-	395	260	52	393	200	52	391	139	52	-	-	-	-	-	-
	67	-	-	-	372	372	51	360	319	51	357	259	51	355	199	51	353	139	51	-	-	-
	62	394	394	52	371	371	51	347	347	51	326	318	51	322	258	51	320	198	51	318	138	51
	57	394	394	52	370	370	51	347	347	51	324	324	51	301	301	51	289	256	50	287	197	50
14,000	77	-	-	-	-	-	-	-	-	-	-	-	-	-	-	-	-	-	-	-	-	-
	72	-	-	-	-	-	-	-	-	-	-	-	-	-	-	-	-	-	-	-	-	-
	67	-	-	-	-	-	-	383	380	51	375	306	51	371	229	51	367	152	51	-	-	-
	62	-	-	-	-	-	-	382	382	51	356	356	51	340	305	51	335	228	51	332	152	51
	57	-	-	-	-	-	-	381	381	51	356	356	51	331	331	51	308	302	51	301	227	51
17,000	77	-	-	-	-	-	-	-	-	-	-	-	-	-	-	-	-	-	-	-	-	-
	72	-	-	-	-	-	-	-	-	-	-	-	-	-	-	-	-	-	-	-	-	-
	67	-	-	-	-	-	-	-	-	-	388	350	52	382	258	51	377	164	51	-	-	-
	62	-	-	-	-	-	-	-	-	-	380	380	51	354	348	51	346	257	51	341	163	51
	57	-	-	-	-	-	-	-	-	-	380	380	51	353	353	51	326	326	51	312	255	51
20,000	77	-	-	-	-	-	-	-	-	-	-	-	-	-	-	-	-	-	-	-	-	-
	72	-	-	-	-	-	-	-	-	-	-	-	-	-	-	-	-	-	-	-	-	-
	67	-	-	-	-	-	-	-	-	-	400	390	52	390	285	52	384	175	51	-	-	-
	62	-	-	-	-	-	-	-	-	-	398	398	52	369	369	51	353	284	51	347	174	51
	57	-	-	-	-	-	-	-	-	-	397	397	52	369	369	51	341	341	51	320	283	51

**Notes:**  
 Rated performance is at sea level. Cooling capacities are gross cooling capacities.  
 CFM = airflow, EWB = entering wet bulb air, EDB = entering dry bulb air, TMBH = total cooling capacity (MBH)  
 SMBH = sensible cooling capacity (MBH), kW = total input

### Cooling performance data 40 ton high capacity

**Table 52: 40 ton high capacity - 75°F ambient air temperature**

CFM	EWB (°F)	95°F EDB			90°F EDB			85°F EDB			80°F EDB			75°F EDB			70°F EDB			65°F EDB		
		TMBH	SMBH	kW	TMBH	SMBH	kW	TMBH	SMBH	kW	TMBH	SMBH	kW	TMBH	SMBH	kW	TMBH	SMBH	kW	TMBH	SMBH	kW
8,000	77	584	331	36	584	288	36	583	244	36	583	200	36	-	-	-	-	-	-	-	-	-
	72	531	375	35	531	332	35	531	289	35	530	245	35	530	201	35	-	-	-	-	-	-
	67	482	418	35	482	375	35	482	332	35	482	289	35	482	246	35	481	202	35	-	-	-
	62	-	-	-	-	-	-	-	-	-	-	-	-	-	-	-	-	-	-	-	-	-
	57	-	-	-	-	-	-	-	-	-	-	-	-	-	-	-	-	-	-	-	-	-
11,000	77	640	401	37	639	341	37	637	281	37	636	221	37	-	-	-	-	-	-	-	-	-
	72	585	462	36	584	402	36	584	343	36	582	283	36	581	223	36	-	-	-	-	-	-
	67	540	522	35	534	462	35	532	403	35	532	344	35	530	283	35	530	224	35	-	-	-
	62	533	533	35	506	506	35	488	462	35	485	402	35	484	343	35	482	283	35	482	224	35
	57	531	531	35	505	505	35	-	-	-	-	-	-	-	-	-	-	-	-	-	-	-
14,000	77	674	466	37	671	389	37	670	313	37	667	236	37	-	-	-	-	-	-	-	-	-
	72	622	543	37	618	468	36	614	391	36	614	315	36	610	238	36	-	-	-	-	-	-
	67	595	595	36	572	544	36	566	469	36	562	392	36	561	316	36	558	239	36	-	-	-
	62	594	594	36	563	563	36	533	533	35	517	469	35	514	393	35	511	317	35	509	240	35
	57	593	593	36	562	562	36	532	532	35	502	502	35	-	-	-	468	392	35	466	316	35
17,000	77	-	-	-	-	-	-	692	343	37	688	249	37	-	-	-	-	-	-	-	-	-
	72	652	622	37	642	530	37	636	437	37	635	345	37	631	252	37	-	-	-	-	-	-
	67	643	643	37	609	609	36	590	531	36	583	438	36	581	346	36	578	253	36	-	-	-
	62	642	642	37	608	608	36	574	574	36	544	531	35	533	439	35	531	347	35	528	254	35
	57	641	641	37	606	606	36	573	573	36	540	540	35	508	508	35	488	438	35	484	347	35
20,000	77	-	-	-	-	-	-	-	-	-	-	-	-	-	-	-	-	-	-	-	-	-
	72	683	683	37	662	591	37	653	482	37	650	374	37	646	264	37	-	-	-	-	-	-
	67	682	682	37	644	644	37	612	591	36	600	483	36	596	375	36	592	266	36	-	-	-
	62	681	681	37	643	643	37	607	607	36	571	571	36	550	484	36	545	376	35	542	267	35
	57	680	680	37	642	642	37	606	606	36	570	570	36	534	534	35	505	483	35	498	376	35

**Table 53: 40 ton high capacity - 85°F ambient air temperature**

CFM	EWB (°F)	95°F EDB			90°F EDB			85°F EDB			80°F EDB			75°F EDB			70°F EDB			65°F EDB		
		TMBH	SMBH	kW	TMBH	SMBH	kW	TMBH	SMBH	kW	TMBH	SMBH	kW	TMBH	SMBH	kW	TMBH	SMBH	kW	TMBH	SMBH	kW
8,000	77	560	319	39	559	276	39	558	232	39	558	188	39	-	-	-	-	-	-	-	-	-
	72	510	365	39	510	322	39	510	279	39	509	235	39	509	191	39	-	-	-	-	-	-
	67	469	412	38	468	369	38	468	326	38	468	283	38	467	240	38	467	196	38	-	-	-
	62	-	-	-	-	-	-	-	-	-	-	-	-	-	-	-	-	-	-	-	-	-
	57	-	-	-	-	-	-	-	-	-	-	-	-	-	-	-	-	-	-	-	-	-
11,000	77	611	388	40	609	328	40	608	268	40	605	207	40	-	-	-	-	-	-	-	-	-
	72	560	450	39	559	391	39	558	331	39	557	271	39	555	211	39	-	-	-	-	-	-
	67	523	514	39	516	455	39	513	395	39	513	336	39	511	276	39	510	216	39	-	-	-
	62	515	515	39	489	489	38	469	451	38	464	391	38	463	332	38	461	272	38	461	212	38
	57	512	512	39	486	486	38	460	460	38	-	-	-	-	-	-	-	-	-	-	-	-
14,000	77	643	453	40	639	376	40	638	300	40	635	222	40	-	-	-	-	-	-	-	-	-
	72	595	531	40	590	455	40	586	379	40	586	303	40	583	226	40	-	-	-	-	-	-
	67	578	578	39	552	535	39	544	460	39	539	383	39	538	308	39	536	231	39	-	-	-
	62	573	573	39	543	543	39	513	513	39	495	457	38	489	380	38	488	305	38	485	228	38
	57	571	571	39	540	540	39	511	511	39	482	482	38	454	452	38	445	378	38	442	302	38
17,000	77	-	-	-	-	-	-	-	-	-	-	-	-	-	-	-	-	-	-	-	-	-
	72	625	608	40	613	518	40	607	425	40	605	332	40	601	239	40	-	-	-	-	-	-
	67	622	622	40	589	589	40	567	522	39	559	429	39	557	337	39	553	244	39	-	-	-
	62	618	618	40	585	585	40	552	552	39	521	516	39	509	426	39	506	335	38	503	242	38
	57	616	616	40	582	582	40	550	550	39	518	518	39	486	486	38	464	424	38	460	333	38
20,000	77	-	-	-	-	-	-	-	-	-	-	-	-	-	-	-	-	-	-	-	-	-
	72	-	-	-	631	577	40	622	469	40	618	361	40	614	251	40	-	-	-	-	-	-
	67	-	-	-	622	622	40	587	578	39	574	473	39	570	365	39	566	256	39	-	-	-
	62	-	-	-	618	618	40	582	582	39	547	547	39	524	471	39	519	363	39	515	254	39
	57	-	-	-	616	616	40	580	580	39	544	544	39	511	511	39	481	468	38	472	362	38

**Table 54: 40 ton high capacity - 95°F ambient air temperature**

CFM	EWB (°F)	95°F EDB			90°F EDB			85°F EDB			80°F EDB			75°F EDB			70°F EDB			65°F EDB		
		TMBH	SMBH	kW	TMBH	SMBH	kW	TMBH	SMBH	kW	TMBH	SMBH	kW	TMBH	SMBH	kW	TMBH	SMBH	kW	TMBH	SMBH	kW
8,000	77	533	307	43	533	263	43	532	219	43	532	176	43	-	-	-	-	-	-	-	-	-
	72	491	357	42	491	314	42	491	271	42	490	227	42	490	184	42	-	-	-	-	-	-
	67	455	408	42	453	365	42	453	322	42	453	279	42	452	235	42	452	192	42	-	-	-
	62	-	-	-	-	-	-	-	-	-	-	-	-	-	-	-	-	-	-	-	-	-
	57	-	-	-	-	-	-	-	-	-	-	-	-	-	-	-	-	-	-	-	-	-
11,000	77	580	375	44	578	315	44	578	255	44	575	194	44	-	-	-	-	-	-	-	-	-
	72	537	442	43	535	382	43	533	322	43	533	262	43	530	202	43	-	-	-	-	-	-
	67	507	506	42	498	449	42	495	389	42	493	329	42	492	269	42	490	209	42	-	-	-
	62	499	499	42	474	474	42	451	442	42	445	383	42	443	323	42	442	263	42	440	203	42
	57	492	492	42	466	466	42	441	441	42	-	-	-	-	-	-	-	-	-	-	-	-
14,000	77	-	-	-	-	-	-	-	-	-	602	209	44	-	-	-	-	-	-	-	-	-
	72	570	522	43	564	446	43	560	369	43	559	293	43	556	216	43	-	-	-	-	-	-
	67	560	560	43	532	526	43	522	452	43	517	375	43	516	300	43	513	223	43	-	-	-
	62	554	554	43	524	524	43	495	495	42	474	447	42	467	370	42	466	295	42	463	218	42
	57	547	547	43	518	518	43	489	489	42	460	460	42	433	433	42	420	364	41	418	288	41
17,000	77	-	-	-	-	-	-	-	-	-	-	-	-	-	-	-	-	-	-	-	-	-
	72	599	595	44	584	507	44	578	414	43	576	322	43	572	228	43	-	-	-	-	-	-
	67	602	602	44	569	569	43	544	513	43	535	420	43	532	328	43	529	235	43	-	-	-
	62	596	596	44	563	563	43	531	531	43	500	500	42	485	416	42	482	324	42	479	231	42
	57	590	590	44	557	557	43	525	525	43	494	494	42	462	462	42	439	410	42	434	318	42
20,000	77	-	-	-	-	-	-	-	-	-	-	-	-	-	-	-	-	-	-	-	-	-
	72	-	-	-	602	565	44	592	458	44	586	349	44	582	239	44	-	-	-	-	-	-
	67	-	-	-	598	598	44	564	563	43	549	464	43	543	356	43	539	246	43	-	-	-
	62	-	-	-	592	592	44	558	558	43	525	525	43	500	460	42	493	352	42	489	243	42
	57	-	-	-	587	587	44	553	553	43	519	519	43	486	486	42	455	451	42	445	347	42

**Table 55: 40 ton high capacity - 105°F ambient air temperature**

CFM	EWB (°F)	95°F EDB			90°F EDB			85°F EDB			80°F EDB			75°F EDB			70°F EDB			65°F EDB		
		TMBH	SMBH	kW	TMBH	SMBH	kW	TMBH	SMBH	kW	TMBH	SMBH	kW	TMBH	SMBH	kW	TMBH	SMBH	kW	TMBH	SMBH	kW
8,000	77	504	293	47	503	250	47	503	206	47	503	162	47	-	-	-	-	-	-	-	-	-
	72	460	339	47	460	296	47	459	253	47	459	209	47	458	166	47	-	-	-	-	-	-
	67	424	388	46	422	345	46	422	302	46	422	259	46	421	215	46	421	172	46	-	-	-
	62	403	403	46	-	-	-	-	-	-	-	-	-	-	-	-	-	-	-	-	-	-
	57	399	399	46	-	-	-	-	-	-	-	-	-	-	-	-	-	-	-	-	-	-
11,000	77	547	361	48	545	301	48	545	241	48	542	180	48	-	-	-	-	-	-	-	-	-
	72	504	424	47	501	364	47	499	304	47	498	244	47	496	184	47	-	-	-	-	-	-
	67	479	479	47	465	429	47	461	369	47	459	309	47	458	250	47	456	189	47	-	-	-
	62	473	473	47	447	447	46	423	422	46	415	364	46	412	304	46	411	245	46	409	184	46
	57	469	469	47	444	444	46	419	419	46	395	395	46	-	-	-	-	-	-	-	-	-
14,000	77	-	-	-	-	-	-	-	-	-	-	-	-	-	-	-	-	-	-	-	-	-
	72	535	503	48	527	427	48	523	351	48	522	275	47	519	198	47	-	-	-	-	-	-
	67	530	530	48	501	501	47	487	433	47	482	356	47	481	280	47	478	203	47	-	-	-
	62	525	525	48	496	496	47	467	467	47	443	428	46	435	352	46	433	276	46	431	199	46
	57	522	522	48	493	493	47	464	464	47	436	436	46	409	409	46	394	349	46	391	273	46
17,000	77	-	-	-	-	-	-	-	-	-	-	-	-	-	-	-	-	-	-	-	-	-
	72	-	-	-	547	488	48	541	396	48	537	303	48	533	210	48	-	-	-	-	-	-
	67	-	-	-	537	537	48	508	492	47	499	401	47	495	309	47	491	215	47	-	-	-
	62	-	-	-	532	532	48	500	500	47	469	469	47	452	397	46	448	305	46	444	212	46
	57	-	-	-	529	529	48	497	497	47	467	467	47	437	437	46	412	394	46	405	303	46
20,000	77	-	-	-	-	-	-	-	-	-	-	-	-	-	-	-	-	-	-	-	-	-
	72	-	-	-	-	-	-	554	441	48	548	331	48	544	222	48	-	-	-	-	-	-
	67	-	-	-	-	-	-	531	531	48	512	445	47	505	336	47	501	227	47	-	-	-
	62	-	-	-	-	-	-	526	526	48	494	494	47	467	441	47	458	333	47	454	224	46
	57	-	-	-	-	-	-	524	524	48	491	491	47	460	460	47	429	429	46	415	330	46

**Table 56: 40 ton high capacity - 115°F ambient air temperature**

CFM	EWB (°F)	95°F EDB			90°F EDB			85°F EDB			80°F EDB			75°F EDB			70°F EDB			65°F EDB		
		TMBH	SMBH	kW	TMBH	SMBH	kW	TMBH	SMBH	kW	TMBH	SMBH	kW	TMBH	SMBH	kW	TMBH	SMBH	kW	TMBH	SMBH	kW
8,000	77	473	279	52	472	236	52	471	192	52	470	148	52	-	-	-	-	-	-	-	-	-
	72	429	323	52	428	280	52	427	236	52	427	193	52	425	148	52	-	-	-	-	-	-
	67	390	366	51	388	322	51	387	279	51	386	236	51	386	193	51	385	149	51	-	-	-
	62	379	379	51	359	359	51	350	321	50	348	278	50	348	235	50	347	192	50	347	148	50
	57	378	378	51	358	358	51	-	-	-	-	-	-	-	-	-	-	-	-	-	-	-
11,000	77	-	-	-	-	-	-	-	-	-	-	-	-	-	-	-	-	-	-	-	-	-
	72	469	407	52	466	347	52	464	287	52	463	227	52	460	166	52	-	-	-	-	-	-
	67	447	447	52	428	407	52	424	347	51	421	287	51	420	228	51	418	167	51	-	-	-
	62	446	446	52	421	421	51	396	396	51	384	346	51	381	286	51	380	227	51	378	167	51
	57	445	445	52	420	420	51	395	395	51	372	372	51	-	-	-	344	285	50	343	225	50
14,000	77	-	-	-	-	-	-	-	-	-	-	-	-	-	-	-	-	-	-	-	-	-
	72	500	485	53	489	410	52	486	334	52	483	257	52	480	180	52	-	-	-	-	-	-
	67	495	495	53	467	467	52	448	410	52	443	334	52	440	258	52	437	181	52	-	-	-
	62	494	494	53	466	466	52	438	438	52	411	407	51	402	334	51	400	258	51	396	181	51
	57	493	493	53	465	465	52	437	437	52	409	409	51	383	383	51	365	332	51	362	257	51
17,000	77	-	-	-	-	-	-	-	-	-	-	-	-	-	-	-	-	-	-	-	-	-
	72	-	-	-	-	-	-	502	379	53	497	286	53	493	193	52	-	-	-	-	-	-
	67	-	-	-	500	500	53	470	467	52	459	379	52	454	287	52	450	194	52	-	-	-
	62	-	-	-	499	499	53	469	469	52	439	439	52	418	379	51	412	286	51	409	194	51
	57	-	-	-	498	498	53	468	468	52	438	438	52	409	409	51	382	376	51	374	285	51
20,000	77	-	-	-	-	-	-	-	-	-	-	-	-	-	-	-	-	-	-	-	-	-
	72	-	-	-	-	-	-	-	-	508	314	53	503	204	53	-	-	-	-	-	-	-
	67	-	-	-	-	-	-	494	494	52	472	423	52	464	315	52	459	205	52	-	-	-
	62	-	-	-	-	-	-	493	493	52	462	462	52	433	421	52	422	314	51	418	205	51
	57	-	-	-	-	-	-	493	493	52	461	461	52	430	430	52	400	400	51	383	314	51

**Table 57: 40 ton high capacity - 125°F ambient air temperature**

CFM	EWB (°F)	95°F EDB			90°F EDB			85°F EDB			80°F EDB			75°F EDB			70°F EDB			65°F EDB		
		TMBH	SMBH	kW	TMBH	SMBH	kW	TMBH	SMBH	kW	TMBH	SMBH	kW	TMBH	SMBH	kW	TMBH	SMBH	kW	TMBH	SMBH	kW
8,000	77	437	264	58	436	221	58	436	177	58	434	133	58	-	-	-	-	-	-	-	-	-
	72	396	307	57	395	264	57	394	221	57	394	177	57	392	133	57	-	-	-	-	-	-
	67	361	350	57	357	307	57	356	264	57	355	220	57	355	177	57	353	133	57	-	-	-
	62	356	356	57	336	336	56	322	305	56	320	262	56	318	219	56	318	176	56	317	132	56
	57	355	355	57	335	335	56	315	315	56	-	-	-	-	-	-	-	-	-	-	-	-
11,000	77	-	-	-	-	-	-	-	-	-	-	-	-	-	-	-	-	-	-	-	-	-
	72	433	390	58	428	330	58	427	271	58	425	210	58	422	150	58	-	-	-	-	-	-
	67	418	418	58	396	389	57	388	330	57	386	270	57	385	211	57	382	150	57	-	-	-
	62	417	417	58	393	393	57	369	369	57	353	329	56	348	269	56	347	210	56	345	150	56
	57	417	417	58	392	392	57	369	369	57	345	345	56	322	322	56	313	268	56	312	208	56
14,000	77	-	-	-	-	-	-	-	-	-	-	-	-	-	-	-	-	-	-	-	-	-
	72	-	-	-	451	393	58	447	317	58	444	241	58	440	164	58	-	-	-	-	-	-
	67	-	-	-	435	435	58	412	392	57	406	317	57	403	241	57	399	164	57	-	-	-
	62	-	-	-	434	434	58	407	407	57	381	381	57	368	316	57	364	240	57	361	164	57
	57	-	-	-	433	433	58	406	406	57	380	380	57	354	354	56	333	315	56	328	239	56
17,000	77	-	-	-	-	-	-	-	-	-	-	-	-	-	-	-	-	-	-	-	-	-
	72	-	-	-	-	-	-	-	-	-	-	-	-	451	176	58	-	-	-	-	-	-
	67	-	-	-	-	-	-	436	436	58	420	362	57	415	269	57	410	176	57	-	-	-
	62	-	-	-	-	-	-	436	436	58	407	407	57	383	361	57	376	269	57	372	176	57
	57	-	-	-	-	-	-	435	435	58	406	406	57	378	378	57	351	351	56	340	268	56
20,000	77	-	-	-	-	-	-	-	-	-	-	-	-	-	-	-	-	-	-	-	-	-
	72	-	-	-	-	-	-	-	-	-	-	-	-	-	-	-	-	-	-	-	-	-
	67	-	-	-	-	-	-	-	-	-	433	405	58	424	297	58	418	187	57	-	-	-
	62	-	-	-	-	-	-	-	-	-	427	427	58	397	397	57	385	297	57	379	187	57
	57	-	-	-	-	-	-	-	-	-	427	427	58	397	397	57	367	367	57	349	295	56

**Notes:**  
 Rated performance is at sea level. Cooling capacities are gross cooling capacities.  
 CFM = airflow, EWB = entering wet bulb air, EDB = entering dry bulb air, TMBH = total cooling capacity (MBH)  
 SMBH = sensible cooling capacity (MBH), kW = total input

## Cooling performance data 50 ton standard efficiency

**Table 58: 50 ton standard efficiency - 75°F ambient air temperature**

CFM	EWB (°F)	95°F EDB			90°F EDB			85°F EDB			80°F EDB			75°F EDB			70°F EDB			65°F EDB		
		TMBH	SMBH	kW	TMBH	SMBH	kW	TMBH	SMBH	kW	TMBH	SMBH	kW	TMBH	SMBH	kW	TMBH	SMBH	kW	TMBH	SMBH	kW
8,000	77	637	352	40	637	309	40	636	265	40	635	221	40	-	-	-	-	-	-	-	-	-
	72	578	396	39	579	353	39	579	310	39	579	267	39	577	222	39	-	-	-	-	-	-
	67	-	-	-	-	-	-	-	-	-	-	-	-	-	-	-	-	-	-	-	-	-
	62	-	-	-	-	-	-	-	-	-	-	-	-	-	-	-	-	-	-	-	-	-
	57	-	-	-	-	-	-	-	-	-	-	-	-	-	-	-	-	-	-	-	-	-
11,000	77	702	424	41	701	364	41	699	303	41	699	243	41	-	-	-	-	-	-	-	-	-
	72	641	485	40	641	425	40	641	366	40	639	305	40	638	246	40	-	-	-	-	-	-
	67	589	545	39	586	486	39	585	426	39	584	367	39	582	307	39	582	247	39	-	-	-
	62	571	571	39	-	-	-	-	-	-	-	-	-	-	-	-	-	-	-	-	-	-
	57	570	570	39	-	-	-	-	-	-	-	-	-	-	-	-	-	-	-	-	-	-
14,000	77	742	489	41	739	412	41	738	336	41	736	259	41	-	-	-	-	-	-	-	-	-
	72	683	567	40	680	491	40	679	415	40	676	339	40	675	262	40	-	-	-	-	-	-
	67	641	640	40	628	569	40	623	493	40	621	417	40	619	341	40	618	265	40	-	-	-
	62	639	639	40	607	607	39	578	568	39	570	493	39	567	417	39	565	341	39	564	265	39
	57	638	638	40	606	606	39	574	574	39	-	-	-	-	-	-	-	-	-	-	-	-
17,000	77	770	552	41	765	459	41	764	367	41	760	273	41	-	-	-	-	-	-	-	-	-
	72	716	647	41	708	555	41	703	461	41	702	369	41	698	276	41	-	-	-	-	-	-
	67	695	695	40	662	647	40	651	557	40	645	464	40	643	371	40	640	278	40	-	-	-
	62	693	693	40	657	657	40	622	622	40	598	557	39	591	465	39	588	372	39	585	280	39
	57	692	692	40	656	656	40	621	621	40	587	587	39	553	553	39	541	465	39	537	372	39
20,000	77	792	614	42	784	504	42	782	395	42	778	285	42	-	-	-	-	-	-	-	-	-
	72	744	722	41	730	616	41	722	507	41	720	398	41	715	288	41	-	-	-	-	-	-
	67	738	738	41	699	699	41	674	618	40	663	509	40	661	401	40	657	291	40	-	-	-
	62	737	737	41	698	698	41	659	659	40	623	616	40	609	510	39	605	402	39	602	293	39
	57	735	735	41	696	696	40	658	658	40	621	621	40	585	585	39	559	510	39	553	402	39

**Table 59: 50 ton standard efficiency - 85°F ambient air temperature**

CFM	EWB (°F)	95°F EDB			90°F EDB			85°F EDB			80°F EDB			75°F EDB			70°F EDB			65°F EDB		
		TMBH	SMBH	kW	TMBH	SMBH	kW	TMBH	SMBH	kW	TMBH	SMBH	kW	TMBH	SMBH	kW	TMBH	SMBH	kW	TMBH	SMBH	kW
8,000	77	611	340	44	611	296	44	609	252	43	610	208	43	-	-	-	-	-	-	-	-	-
	72	559	387	43	559	344	43	559	301	43	559	257	43	558	213	43	-	-	-	-	-	-
	67	-	-	-	-	-	-	-	-	-	-	-	-	-	-	-	515	222	42	-	-	-
	62	-	-	-	-	-	-	-	-	-	-	-	-	-	-	-	-	-	-	-	-	-
	57	-	-	-	-	-	-	-	-	-	-	-	-	-	-	-	-	-	-	-	-	-
11,000	77	672	410	44	671	350	44	669	290	44	668	230	44	-	-	-	-	-	-	-	-	-
	72	617	474	43	616	415	43	616	355	43	614	295	43	613	235	43	-	-	-	-	-	-
	67	575	542	43	571	482	43	569	423	43	569	363	43	567	303	43	566	243	43	-	-	-
	62	555	555	43	528	528	42	515	475	42	512	415	42	511	356	42	509	296	42	509	237	42
	57	550	550	43	523	523	42	-	-	-	-	-	-	-	-	-	-	-	-	-	-	-
14,000	77	709	475	45	706	398	45	705	322	45	701	245	45	-	-	-	-	-	-	-	-	-
	72	656	556	44	652	480	44	649	403	44	648	327	44	645	250	44	-	-	-	-	-	-
	67	627	627	43	609	563	43	604	487	43	601	411	43	599	335	43	597	258	43	-	-	-
	62	619	619	43	588	588	43	558	555	43	547	482	43	543	406	43	541	330	42	540	254	42
	57	615	615	43	584	584	43	553	553	43	523	523	42	-	-	-	-	-	-	-	-	-
17,000	77	735	538	45	730	445	45	729	352	45	725	258	45	-	-	-	-	-	-	-	-	-
	72	687	635	44	678	542	44	673	449	44	671	357	44	667	263	44	-	-	-	-	-	-
	67	677	677	44	643	638	44	629	550	44	622	456	43	621	365	43	617	271	43	-	-	-
	62	670	670	44	635	635	44	601	601	43	574	545	43	565	452	43	563	360	43	559	267	43
	57	666	666	44	631	631	44	597	597	43	563	563	43	530	530	42	514	449	42	511	357	42
20,000	77	-	-	-	-	-	-	746	381	45	741	271	45	-	-	-	-	-	-	-	-	-
	72	715	707	45	699	603	44	690	494	44	688	386	44	683	276	44	-	-	-	-	-	-
	67	717	717	45	679	679	44	651	610	44	639	501	44	636	393	44	632	283	44	-	-	-
	62	711	711	45	673	673	44	636	636	44	599	599	43	582	497	43	578	389	43	574	280	43
	57	708	708	45	670	670	44	632	632	44	596	596	43	560	560	43	532	494	42	526	387	42

**Table 60: 50 ton standard efficiency - 95°F ambient air temperature**

CFM	EWB (°F)	95°F EDB			90°F EDB			85°F EDB			80°F EDB			75°F EDB			70°F EDB			65°F EDB		
		TMBH	SMBH	kW	TMBH	SMBH	kW	TMBH	SMBH	kW	TMBH	SMBH	kW	TMBH	SMBH	kW	TMBH	SMBH	kW	TMBH	SMBH	kW
8,000	77	584	327	48	584	283	48	582	239	48	583	195	48	-	-	-	-	-	-	-	-	-
	72	543	383	47	543	340	47	543	297	47	542	253	47	542	210	47	-	-	-	-	-	-
	67	508	440	46	507	397	46	507	354	46	507	311	46	507	268	46	506	224	46	-	-	-
	62	-	-	-	-	-	-	-	-	-	-	-	-	-	-	-	-	-	-	-	-	-
	57	-	-	-	-	-	-	-	-	-	-	-	-	-	-	-	-	-	-	-	-	-
11,000	77	640	396	48	638	336	48	637	276	48	636	215	48	-	-	-	-	-	-	-	-	-
	72	596	468	48	595	409	48	594	349	48	592	289	48	591	228	48	-	-	-	-	-	-
	67	562	540	47	557	481	47	554	421	47	554	362	47	552	301	47	551	242	47	-	-	-
	62	542	542	47	516	516	47	499	469	46	495	410	46	494	350	46	493	290	46	492	231	46
	57	529	529	47	502	502	47	-	-	-	-	-	-	-	-	-	-	-	-	-	-	-
14,000	77	674	461	49	671	384	49	670	308	49	667	230	49	-	-	-	-	-	-	-	-	-
	72	632	548	48	627	472	48	624	395	48	623	320	48	619	242	48	-	-	-	-	-	-
	67	614	614	48	592	560	47	585	484	47	581	407	47	580	332	47	577	255	47	-	-	-
	62	603	603	48	572	572	47	542	542	47	527	475	47	522	398	47	521	322	47	518	246	47
	57	591	591	48	560	560	47	530	530	47	500	500	47	-	-	-	-	-	-	-	-	-
17,000	77	-	-	-	694	430	49	692	338	49	688	244	49	-	-	-	-	-	-	-	-	-
	72	661	626	49	651	534	48	645	441	48	643	348	48	639	255	48	-	-	-	-	-	-
	67	660	660	48	626	626	48	609	545	48	601	452	48	599	360	48	596	267	47	-	-	-
	62	650	650	48	616	616	48	582	582	47	553	536	47	542	444	47	540	352	47	537	259	47
	57	640	640	48	605	605	48	572	572	47	539	539	47	506	506	47	486	433	46	483	342	46
20,000	77	-	-	-	-	-	-	-	-	-	-	-	-	-	-	-	-	-	-	-	-	-
	72	690	690	49	669	594	49	661	485	49	658	376	48	653	266	48	-	-	-	-	-	-
	67	697	697	49	660	660	48	628	603	48	616	496	48	613	387	48	609	278	48	-	-	-
	62	688	688	49	651	651	48	614	614	48	578	578	47	559	488	47	554	380	47	550	271	47
	57	679	679	49	641	641	48	605	605	48	568	568	47	533	533	47	504	478	47	497	371	46

**Table 61: 50 ton standard efficiency - 105°F ambient air temperature**

CFM	EWB (°F)	95°F EDB			90°F EDB			85°F EDB			80°F EDB			75°F EDB			70°F EDB			65°F EDB		
		TMBH	SMBH	kW	TMBH	SMBH	kW	TMBH	SMBH	kW	TMBH	SMBH	kW	TMBH	SMBH	kW	TMBH	SMBH	kW	TMBH	SMBH	kW
8,000	77	554	312	53	554	269	53	552	225	53	553	181	53	-	-	-	-	-	-	-	-	-
	72	507	360	52	507	317	52	507	274	52	505	230	52	505	187	52	-	-	-	-	-	-
	67	470	413	51	469	370	51	469	327	51	469	284	51	468	240	51	468	197	51	-	-	-
	62	-	-	-	-	-	-	-	-	-	-	-	-	-	-	-	-	-	-	-	-	-
	57	-	-	-	-	-	-	-	-	-	-	-	-	-	-	-	-	-	-	-	-	-
11,000	77	605	381	53	603	321	53	603	261	53	600	200	53	-	-	-	-	-	-	-	-	-
	72	557	446	53	556	386	52	553	326	52	553	266	52	550	205	52	-	-	-	-	-	-
	67	525	514	52	517	455	52	515	396	52	513	336	52	512	276	52	510	216	52	-	-	-
	62	511	511	52	485	485	52	464	446	51	460	386	51	458	327	51	457	267	51	456	207	51
	57	506	506	52	479	479	51	453	453	51	-	-	-	-	-	-	-	-	-	-	-	-
14,000	77	637	445	54	634	369	54	632	292	54	629	215	54	-	-	-	-	-	-	-	-	-
	72	592	526	53	586	450	53	583	374	53	582	298	53	578	221	53	-	-	-	-	-	-
	67	579	579	53	553	535	52	545	459	52	540	383	52	539	307	52	536	230	52	-	-	-
	62	570	570	53	539	539	52	509	509	52	491	451	52	484	375	51	483	299	51	480	222	51
	57	565	565	53	534	534	52	504	504	52	475	475	51	447	445	51	436	370	51	435	294	51
17,000	77	-	-	-	-	-	-	-	-	-	-	-	-	-	-	-	-	-	-	-	-	-
	72	621	603	53	608	512	53	603	419	53	600	327	53	597	233	53	-	-	-	-	-	-
	67	623	623	53	590	590	53	567	521	52	559	428	52	557	336	52	553	243	52	-	-	-
	62	615	615	53	581	581	53	548	548	52	516	511	52	504	421	52	501	329	52	498	236	52
	57	610	610	53	577	577	53	544	544	52	511	511	52	478	478	51	457	417	51	452	325	51
20,000	77	-	-	-	-	-	-	-	-	-	-	-	-	-	-	-	-	-	-	-	-	-
	72	-	-	-	627	571	53	618	464	53	613	354	53	609	245	53	-	-	-	-	-	-
	67	-	-	-	621	621	53	587	577	53	574	472	53	569	363	52	565	254	52	-	-	-
	62	-	-	-	614	614	53	577	577	53	542	542	52	520	466	52	514	357	52	510	248	52
	57	-	-	-	610	610	53	573	573	53	538	538	52	504	504	52	474	460	51	465	354	51

**Table 62: 50 ton standard efficiency - 115°F ambient air temperature**

CFM	EWB (°F)	95°F EDB			90°F EDB			85°F EDB			80°F EDB			75°F EDB			70°F EDB			65°F EDB		
		TMBH	SMBH	kW	TMBH	SMBH	kW	TMBH	SMBH	kW	TMBH	SMBH	kW	TMBH	SMBH	kW	TMBH	SMBH	kW	TMBH	SMBH	kW
8,000	77	521	297	58	520	253	58	520	210	58	519	166	58	-	-	-	-	-	-	-	-	-
	72	472	341	57	472	298	57	471	254	57	470	211	57	470	167	57	-	-	-	-	-	-
	67	428	383	57	426	340	57	426	297	57	426	254	57	425	211	57	425	167	57	-	-	-
	62	407	407	57	-	-	-	-	-	-	-	-	-	-	-	-	-	-	-	-	-	-
	57	405	405	57	-	-	-	-	-	-	-	-	-	-	-	-	-	-	-	-	-	-
11,000	77	567	365	59	566	305	59	565	245	59	562	184	59	-	-	-	-	-	-	-	-	-
	72	519	426	58	517	366	58	515	306	58	514	246	58	512	186	58	-	-	-	-	-	-
	67	483	483	58	473	426	57	470	367	57	467	307	57	467	247	57	464	187	57	-	-	-
	62	481	481	58	455	455	57	431	425	57	425	366	57	422	305	57	422	246	57	420	186	57
	57	480	480	58	454	454	57	428	428	57	-	-	-	-	-	-	-	-	-	-	-	-
14,000	77	-	-	-	-	-	-	-	-	-	-	-	-	-	-	-	-	-	-	-	-	-
	72	552	507	59	545	430	58	542	354	58	540	278	58	537	201	58	-	-	-	-	-	-
	67	538	538	58	509	505	58	498	431	58	493	355	58	492	279	58	489	202	58	-	-	-
	62	537	537	58	507	507	58	477	477	57	455	430	57	448	354	57	446	278	57	443	202	57
	57	535	535	58	506	506	58	476	476	57	447	447	57	419	419	57	406	352	56	403	277	56
17,000	77	-	-	-	-	-	-	-	-	-	-	-	-	-	-	-	-	-	-	-	-	-
	72	582	579	59	566	492	59	560	399	59	556	306	59	552	213	58	-	-	-	-	-	-
	67	581	581	59	547	547	58	520	492	58	512	400	58	508	308	58	504	214	58	-	-	-
	62	579	579	59	546	546	58	513	513	58	481	481	57	466	400	57	462	308	57	458	215	57
	57	578	578	59	545	545	58	512	512	58	480	480	57	449	449	57	425	398	57	419	307	57
20,000	77	-	-	-	-	-	-	-	-	-	-	-	-	-	-	-	-	-	-	-	-	-
	72	-	-	-	585	551	59	574	444	59	568	334	59	564	225	59	-	-	-	-	-	-
	67	-	-	-	577	577	59	542	542	58	526	445	58	519	336	58	515	226	58	-	-	-
	62	-	-	-	576	576	59	541	541	58	507	507	58	481	444	57	473	336	57	469	226	57
	57	-	-	-	575	575	59	540	540	58	506	506	58	473	473	57	442	439	57	429	335	57

**Table 63: 50 ton standard efficiency - 125°F ambient air temperature**

CFM	EWB (°F)	95°F EDB			90°F EDB			85°F EDB			80°F EDB			75°F EDB			70°F EDB			65°F EDB		
		TMBH	SMBH	kW	TMBH	SMBH	kW	TMBH	SMBH	kW	TMBH	SMBH	kW	TMBH	SMBH	kW	TMBH	SMBH	kW	TMBH	SMBH	kW
8,000	77	485	281	65	483	237	65	483	194	65	481	149	64	-	-	-	-	-	-	-	-	-
	72	438	324	64	438	281	64	436	237	64	436	194	64	435	150	64	-	-	-	-	-	-
	67	396	366	63	394	323	63	394	280	63	393	237	63	393	193	63	392	150	63	-	-	-
	62	383	383	63	362	362	63	-	-	-	-	-	-	353	235	63	352	192	63	352	148	63
	57	382	382	63	-	-	-	-	-	-	-	-	-	-	-	-	-	-	-	-	-	-
11,000	77	-	-	-	-	-	-	522	228	65	520	167	65	-	-	-	-	-	-	-	-	-
	72	481	409	64	477	349	64	476	289	64	475	229	64	472	168	64	-	-	-	-	-	-
	67	454	454	64	437	408	64	433	349	64	431	289	64	430	229	64	428	169	64	-	-	-
	62	452	452	64	427	427	64	402	402	63	392	348	63	388	287	63	387	228	63	385	168	63
	57	451	451	64	426	426	64	401	401	63	376	376	63	-	-	-	-	-	-	-	-	-
14,000	77	-	-	-	-	-	-	-	-	-	-	-	-	-	-	-	-	-	-	-	-	-
	72	512	488	65	503	412	65	500	336	65	497	259	65	493	182	65	-	-	-	-	-	-
	67	505	505	65	476	476	64	459	412	64	454	336	64	451	260	64	448	183	64	-	-	-
	62	504	504	65	475	475	64	446	446	64	419	410	63	411	335	63	408	259	63	405	182	63
	57	503	503	65	474	474	64	445	445	64	416	416	63	388	388	63	372	334	63	368	258	63
17,000	77	-	-	-	-	-	-	-	-	-	-	-	-	-	-	-	-	-	-	-	-	-
	72	-	-	-	524	473	65	517	381	65	512	288	65	508	195	65	-	-	-	-	-	-
	67	-	-	-	511	511	65	481	471	64	471	382	64	466	289	64	462	195	64	-	-	-
	62	-	-	-	510	510	65	478	478	64	448	448	64	428	381	64	422	288	63	419	195	63
	57	-	-	-	509	509	65	477	477	64	447	447	64	417	417	63	390	378	63	381	287	63
20,000	77	-	-	-	-	-	-	-	-	-	-	-	-	-	-	-	-	-	-	-	-	-
	72	-	-	-	-	-	-	-	-	-	523	316	65	518	206	65	-	-	-	-	-	-
	67	-	-	-	-	-	-	505	505	65	484	426	64	477	317	64	472	207	64	-	-	-
	62	-	-	-	-	-	-	505	505	65	472	472	64	443	424	64	433	316	64	428	207	63
	57	-	-	-	-	-	-	504	504	65	471	471	64	439	439	64	408	408	63	392	315	63

**Notes:**

Rated performance is at sea level. Cooling capacities are gross cooling capacities.  
 CFM = airflow, EWB = entering wet bulb air, EDB = entering dry bulb air, TMBH = total cooling capacity (MBH)  
 SMBH = sensible cooling capacity (MBH), kW = total input

## Cooling performance data 50 ton high efficiency

**Table 64: 50 ton high efficiency - 75°F ambient air temperature**

CFM	EWB (°F)	95°F EDB			90°F EDB			85°F EDB			80°F EDB			75°F EDB			70°F EDB			65°F EDB		
		TMBH	SMBH	kW	TMBH	SMBH	kW	TMBH	SMBH	kW	TMBH	SMBH	kW	TMBH	SMBH	kW	TMBH	SMBH	kW	TMBH	SMBH	kW
8,000	77	648	356	38	648	313	38	649	269	38	649	225	38	-	-	-	-	-	-	-	-	-
	72	588	400	38	587	357	38	588	313	38	588	270	38	588	226	38	-	-	-	-	-	-
	67	-	-	-	-	-	-	-	-	-	-	-	-	-	-	-	-	-	-	-	-	-
	62	-	-	-	-	-	-	-	-	-	-	-	-	-	-	-	-	-	-	-	-	-
	57	-	-	-	-	-	-	-	-	-	-	-	-	-	-	-	-	-	-	-	-	-
11,000	77	719	430	39	719	370	39	719	310	39	717	249	39	-	-	-	-	-	-	-	-	-
	72	655	491	38	654	431	38	655	372	38	654	312	38	653	251	38	-	-	-	-	-	-
	67	600	551	38	596	491	38	595	431	38	595	372	38	595	312	38	594	252	38	-	-	-
	62	579	579	38	-	-	-	-	-	-	-	-	-	-	-	-	-	-	-	-	-	-
	57	578	578	38	-	-	-	-	-	-	-	-	-	-	-	-	-	-	-	-	-	-
14,000	77	763	498	39	762	421	39	761	345	39	759	267	39	-	-	-	-	-	-	-	-	-
	72	700	575	39	697	499	39	696	423	39	696	347	39	693	269	39	-	-	-	-	-	-
	67	652	652	38	640	576	38	636	500	38	635	424	38	634	348	38	632	271	38	-	-	-
	62	651	651	38	617	617	38	587	577	38	580	499	38	578	423	38	578	347	38	576	271	38
	57	649	649	38	616	616	38	583	583	38	-	-	-	-	-	-	-	-	-	-	-	-
17,000	77	-	-	-	-	-	-	-	-	-	-	-	-	-	-	-	-	-	-	-	-	-
	72	734	657	39	728	564	39	725	471	39	722	378	39	721	284	39	-	-	-	-	-	-
	67	709	709	39	676	659	38	666	565	38	663	472	38	661	379	38	659	286	38	-	-	-
	62	708	708	39	671	671	38	634	634	38	610	566	38	605	472	38	603	380	38	601	287	38
	57	706	706	39	669	669	38	633	633	38	597	597	38	563	563	38	552	472	38	549	379	38
20,000	77	-	-	-	-	-	-	-	-	-	-	-	-	-	-	-	-	-	-	-	-	-
	72	763	737	39	751	627	39	746	517	39	742	407	39	740	298	39	-	-	-	-	-	-
	67	756	756	39	715	715	39	690	629	39	683	519	38	679	409	38	677	300	38	-	-	-
	62	754	754	39	714	714	39	674	674	38	637	629	38	625	519	38	620	409	38	619	300	38
	57	753	753	39	713	713	39	673	673	38	634	634	38	597	597	38	572	519	38	566	409	38

**Table 65: 50 ton high efficiency - 85°F ambient air temperature**

CFM	EWB (°F)	95°F EDB			90°F EDB			85°F EDB			80°F EDB			75°F EDB			70°F EDB			65°F EDB		
		TMBH	SMBH	kW	TMBH	SMBH	kW	TMBH	SMBH	kW	TMBH	SMBH	kW	TMBH	SMBH	kW	TMBH	SMBH	kW	TMBH	SMBH	kW
8,000	77	623	344	42	623	300	42	623	256	42	623	213	42	-	-	-	-	-	-	-	-	-
	72	565	388	42	565	344	42	565	301	42	565	258	42	565	214	42	-	-	-	-	-	-
	67	-	-	-	-	-	-	-	-	-	-	-	-	-	-	-	-	-	-	-	-	-
	62	-	-	-	-	-	-	-	-	-	-	-	-	-	-	-	-	-	-	-	-	-
	57	-	-	-	-	-	-	-	-	-	-	-	-	-	-	-	-	-	-	-	-	-
11,000	77	689	417	43	689	357	43	688	297	43	687	236	43	-	-	-	-	-	-	-	-	-
	72	628	477	42	627	418	42	627	358	42	627	299	42	626	238	42	-	-	-	-	-	-
	67	577	540	42	573	479	42	572	420	42	572	360	42	571	300	42	570	240	42	-	-	-
	62	560	560	42	532	532	42	-	-	-	517	417	41	517	358	41	517	298	41	-	-	-
	57	558	558	42	-	-	-	-	-	-	-	-	-	-	-	-	-	-	-	-	-	-
14,000	77	730	484	43	729	407	43	727	330	43	726	253	43	-	-	-	-	-	-	-	-	-
	72	670	562	43	667	485	43	666	409	43	665	332	43	663	255	42	-	-	-	-	-	-
	67	631	631	42	614	564	42	610	487	42	608	411	42	608	335	42	606	258	42	-	-	-
	62	628	628	42	596	596	42	564	562	42	555	486	42	552	409	42	552	333	42	557	259	42
	57	626	626	42	594	594	42	562	562	42	530	530	41	-	-	-	-	-	-	-	-	-
17,000	77	-	-	-	-	-	-	-	-	-	-	-	-	-	-	-	-	-	-	-	-	-
	72	703	643	43	696	550	43	692	457	43	689	363	43	688	270	43	-	-	-	-	-	-
	67	686	686	43	650	645	42	638	552	42	634	459	42	631	366	42	629	273	42	-	-	-
	62	683	683	43	646	646	42	611	611	42	584	551	42	577	458	42	574	365	42	573	272	42
	57	681	681	43	645	645	42	609	609	42	574	574	42	540	540	42	525	456	41	522	364	41
20,000	77	-	-	-	-	-	-	-	-	-	-	-	-	-	-	-	-	-	-	-	-	-
	72	733	722	43	718	613	43	712	503	43	708	393	43	704	283	43	-	-	-	-	-	-
	67	730	730	43	690	690	43	661	615	42	653	505	42	648	395	42	645	285	42	-	-	-
	62	728	728	43	688	688	43	649	649	42	611	611	42	596	505	42	591	395	42	588	285	42
	57	726	726	43	686	686	43	647	647	42	609	609	42	572	572	42	545	504	42	538	393	42

**Table 66: 50 ton high efficiency - 95°F ambient air temperature**

CFM	EWB (°F)	95°F EDB			90°F EDB			85°F EDB			80°F EDB			75°F EDB			70°F EDB			65°F EDB		
		TMBH	SMBH	kW	TMBH	SMBH	kW	TMBH	SMBH	kW	TMBH	SMBH	kW	TMBH	SMBH	kW	TMBH	SMBH	kW	TMBH	SMBH	kW
8,000	77	595	330	47	596	287	47	596	243	47	596	199	47	-	-	-	-	-	-	-	-	-
	72	541	376	46	541	333	46	541	290	46	542	246	46	542	203	46	-	-	-	-	-	-
	67	493	421	45	492	378	45	492	335	45	492	292	45	492	249	45	493	205	45	-	-	-
	62	-	-	-	-	-	-	-	-	-	-	-	-	-	-	-	-	-	-	-	-	-
	57	-	-	-	-	-	-	-	-	-	-	-	-	-	-	-	-	-	-	-	-	-
11,000	77	657	402	47	657	343	47	655	282	47	654	221	47	-	-	-	-	-	-	-	-	-
	72	600	465	47	599	405	47	599	346	47	599	286	47	597	225	47	-	-	-	-	-	-
	67	553	528	46	548	467	46	547	408	46	546	348	46	546	289	46	545	228	46	-	-	-
	62	540	540	46	512	512	46	496	464	46	493	404	45	493	345	45	493	285	45	482	222	45
	57	536	536	46	508	508	46	-	-	-	-	-	-	-	-	-	-	-	-	-	-	-
14,000	77	-	-	-	-	-	-	-	-	-	-	-	-	-	-	-	-	-	-	-	-	-
	72	640	548	47	636	472	47	635	396	47	633	319	47	631	242	47	-	-	-	-	-	-
	67	609	609	47	588	551	46	582	474	46	580	398	46	578	322	46	577	245	46	-	-	-
	62	605	605	47	573	573	46	542	542	46	529	472	46	526	396	46	524	320	46	523	243	46
	57	602	602	47	569	569	46	538	538	46	507	507	46	-	-	-	-	-	-	-	-	-
17,000	77	-	-	-	-	-	-	-	-	-	-	-	-	-	-	-	-	-	-	-	-	-
	72	671	630	47	663	536	47	659	443	47	656	349	47	653	256	47	-	-	-	-	-	-
	67	661	661	47	625	625	47	609	539	47	604	446	47	601	352	46	598	259	46	-	-	-
	62	657	657	47	621	621	47	586	586	46	556	537	46	549	444	46	545	350	46	543	258	46
	57	654	654	47	618	618	47	583	583	46	549	549	46	515	515	46	498	441	46	493	347	45
20,000	77	-	-	-	-	-	-	-	-	-	-	-	-	-	-	-	-	-	-	-	-	-
	72	-	-	-	684	599	47	677	489	47	673	379	47	668	268	47	-	-	-	-	-	-
	67	-	-	-	663	663	47	631	602	47	621	492	47	617	382	47	613	271	47	-	-	-
	62	-	-	-	660	660	47	622	622	47	585	585	46	566	490	46	561	380	46	557	270	46
	57	-	-	-	657	657	47	619	619	47	582	582	46	546	546	46	516	488	46	508	377	46

**Table 67: 50 ton high efficiency - 105°F ambient air temperature**

CFM	EWB (°F)	95°F EDB			90°F EDB			85°F EDB			80°F EDB			75°F EDB			70°F EDB			65°F EDB		
		TMBH	SMBH	kW	TMBH	SMBH	kW	TMBH	SMBH	kW	TMBH	SMBH	kW	TMBH	SMBH	kW	TMBH	SMBH	kW	TMBH	SMBH	kW
8,000	77	565	316	51	565	273	51	565	229	51	565	185	51	-	-	-	-	-	-	-	-	-
	72	511	360	51	512	317	51	512	274	51	512	230	51	511	186	51	-	-	-	-	-	-
	67	464	404	50	463	361	50	463	318	50	464	275	50	464	232	50	464	188	50	-	-	-
	62	-	-	-	-	-	-	-	-	-	-	-	-	-	-	-	-	-	-	-	-	-
	57	-	-	-	-	-	-	-	-	-	-	-	-	-	-	-	-	-	-	-	-	-
11,000	77	622	387	52	622	327	52	620	267	52	619	206	52	-	-	-	-	-	-	-	-	-
	72	567	448	51	566	388	51	565	329	51	564	268	51	563	208	51	-	-	-	-	-	-
	67	521	510	51	516	450	51	515	390	51	514	331	51	514	271	51	513	210	51	-	-	-
	62	514	514	51	487	487	50	467	447	50	464	387	50	463	328	50	463	268	50	462	208	50
	57	512	512	51	485	485	50	458	458	50	-	-	-	-	-	-	-	-	-	-	-	-
14,000	77	-	-	-	-	-	-	-	-	-	-	-	-	-	-	-	-	-	-	-	-	-
	72	604	531	52	600	455	52	598	378	52	596	302	52	594	224	52	-	-	-	-	-	-
	67	580	580	51	554	534	51	548	457	51	546	380	51	544	304	51	542	227	51	-	-	-
	62	577	577	51	545	545	51	514	514	51	497	455	50	493	378	50	491	302	50	490	225	50
	57	575	575	51	543	543	51	512	512	51	482	482	50	453	452	50	446	376	50	444	299	50
17,000	77	-	-	-	-	-	-	-	-	-	-	-	-	-	-	-	-	-	-	-	-	-
	72	-	-	-	625	519	52	620	425	52	617	332	52	614	238	52	-	-	-	-	-	-
	67	629	629	52	594	594	52	573	521	51	567	428	51	564	334	51	561	241	51	-	-	-
	62	626	626	52	591	591	52	557	557	51	524	519	51	515	426	51	511	332	51	508	239	51
	57	624	624	52	589	589	52	555	555	51	521	521	51	489	489	50	467	424	50	463	330	50
20,000	77	-	-	-	-	-	-	-	-	-	-	-	-	-	-	-	-	-	-	-	-	-
	72	-	-	-	-	-	-	-	-	-	632	361	52	628	251	52	-	-	-	-	-	-
	67	-	-	-	630	630	52	595	583	52	584	473	51	579	363	51	575	253	51	-	-	-
	62	-	-	-	628	628	52	590	590	51	554	554	51	532	472	51	525	362	51	522	252	51
	57	-	-	-	626	626	52	589	589	51	552	552	51	517	517	51	485	470	50	477	360	50

**Table 68: 50 ton high efficiency - 115°F ambient air temperature**

CFM	EWB (°F)	95°F EDB			90°F EDB			85°F EDB			80°F EDB			75°F EDB			70°F EDB			65°F EDB		
		TMBH	SMBH	kW	TMBH	SMBH	kW	TMBH	SMBH	kW	TMBH	SMBH	kW	TMBH	SMBH	kW	TMBH	SMBH	kW	TMBH	SMBH	kW
8,000	77	532	301	57	532	258	57	532	214	57	532	170	57	-	-	-	-	-	-	-	-	-
	72	480	344	56	480	301	56	480	257	56	480	214	56	480	170	56	-	-	-	-	-	-
	67	433	386	55	432	343	55	432	300	55	432	257	55	433	213	55	451	175	56	-	-	-
	62	-	-	-	-	-	-	-	-	-	-	-	-	-	-	-	-	-	-	-	-	-
	57	-	-	-	-	-	-	-	-	-	-	-	-	-	-	-	-	-	-	-	-	-
11,000	77	-	-	-	-	-	-	-	-	-	-	-	-	-	-	-	-	-	-	-	-	-
	72	531	431	57	529	371	57	529	312	57	528	251	57	527	191	57	-	-	-	-	-	-
	67	489	489	56	481	431	56	479	371	56	479	311	56	477	251	56	477	191	56	-	-	-
	62	488	488	56	461	461	56	437	430	55	433	370	55	432	310	55	431	250	55	422	187	55
	57	486	486	56	460	460	56	434	434	55	-	-	-	-	-	-	-	-	-	-	-	-
14,000	77	-	-	-	-	-	-	-	-	-	-	-	-	-	-	-	-	-	-	-	-	-
	72	566	514	57	561	437	57	559	361	57	557	284	57	554	207	57	-	-	-	-	-	-
	67	548	548	57	518	514	56	510	437	56	507	361	56	505	284	56	503	207	56	-	-	-
	62	547	547	57	516	516	56	486	486	56	464	437	56	459	360	56	457	284	56	455	207	56
	57	545	545	57	515	515	56	484	484	56	455	455	56	426	426	55	415	358	55	413	282	55
17,000	77	-	-	-	-	-	-	-	-	-	-	-	-	-	-	-	-	-	-	-	-	-
	72	-	-	-	-	-	-	579	407	57	576	314	57	572	220	57	-	-	-	-	-	-
	67	-	-	-	560	560	57	534	501	57	527	408	57	524	315	56	521	221	56	-	-	-
	62	-	-	-	559	559	57	525	525	57	492	492	56	479	407	56	475	314	56	472	221	56
	57	-	-	-	557	557	57	524	524	56	491	491	56	459	459	56	435	406	55	430	313	55
20,000	77	-	-	-	-	-	-	-	-	-	-	-	-	-	-	-	-	-	-	-	-	-
	72	-	-	-	-	-	-	-	-	-	-	-	-	-	-	-	-	-	-	-	-	-
	67	-	-	-	-	-	-	557	557	57	542	453	57	537	344	57	533	233	57	-	-	-
	62	-	-	-	-	-	-	556	556	57	521	521	56	494	453	56	488	343	56	484	233	56
	57	-	-	-	-	-	-	555	555	57	520	520	56	485	485	56	452	450	55	442	342	55

**Table 69: 50 ton high efficiency - 125°F ambient air temperature**

CFM	EWB (°F)	95°F EDB			90°F EDB			85°F EDB			80°F EDB			75°F EDB			70°F EDB			65°F EDB		
		TMBH	SMBH	kW	TMBH	SMBH	kW	TMBH	SMBH	kW	TMBH	SMBH	kW	TMBH	SMBH	kW	TMBH	SMBH	kW	TMBH	SMBH	kW
8,000	77	496	285	63	496	241	63	495	197	63	495	154	63	-	-	-	-	-	-	-	-	-
	72	446	327	62	446	284	62	446	241	62	446	197	62	446	154	62	-	-	-	-	-	-
	67	402	369	61	401	326	61	401	283	61	401	240	61	401	197	61	400	153	61	-	-	-
	62	386	386	61	-	-	-	-	-	-	-	-	-	-	-	-	-	-	-	-	-	-
	57	385	385	61	-	-	-	-	-	-	-	-	-	-	-	-	-	-	-	-	-	-
11,000	77	-	-	-	-	-	-	-	-	-	-	-	-	-	-	-	-	-	-	-	-	-
	72	492	414	63	490	354	63	490	294	63	489	234	63	487	173	63	-	-	-	-	-	-
	67	460	460	62	446	413	62	443	353	62	442	294	62	441	234	62	440	173	62	-	-	-
	62	459	459	62	433	433	62	407	407	61	400	352	61	398	292	61	397	233	61	396	173	61
	57	458	458	62	432	432	62	406	406	61	382	382	61	-	-	-	-	-	-	-	-	-
14,000	77	-	-	-	-	-	-	-	-	-	-	-	-	-	-	-	-	-	-	-	-	-
	72	-	-	-	519	419	63	516	343	63	514	266	63	511	189	63	-	-	-	-	-	-
	67	515	515	63	485	485	63	471	419	62	468	343	62	466	266	62	463	189	62	-	-	-
	62	514	514	63	484	484	62	454	454	62	428	418	62	423	342	62	421	265	62	419	188	61
	57	513	513	63	483	483	62	453	453	62	425	425	62	397	397	61	381	340	61	379	263	61
17,000	77	-	-	-	-	-	-	-	-	-	-	-	-	-	-	-	-	-	-	-	-	-
	72	-	-	-	-	-	-	-	-	-	-	-	-	-	-	-	-	-	-	-	-	-
	67	-	-	-	-	-	-	494	482	63	485	389	62	482	296	62	478	202	62	-	-	-
	62	-	-	-	-	-	-	491	491	63	459	459	62	440	388	62	436	295	62	433	202	62
	57	-	-	-	-	-	-	490	490	63	458	458	62	427	427	62	400	387	61	394	294	61
20,000	77	-	-	-	-	-	-	-	-	-	-	-	-	-	-	-	-	-	-	-	-	-
	72	-	-	-	-	-	-	-	-	-	-	-	-	-	-	-	-	-	-	-	-	-
	67	-	-	-	-	-	-	520	520	63	499	434	63	494	325	63	489	214	63	-	-	-
	62	-	-	-	-	-	-	519	519	63	485	485	62	455	434	62	448	324	62	443	214	62
	57	-	-	-	-	-	-	518	518	63	484	484	62	450	450	62	418	418	61	405	323	61

**Notes:**  
 Rated performance is at sea level. Cooling capacities are gross cooling capacities.  
 CFM = airflow, EWB = entering wet bulb air, EDB = entering dry bulb air, TMBH = total cooling capacity (MBH)  
 SMBH = sensible cooling capacity (MBH), kW = total input

## Cooling performance data 50 ton high capacity

**Table 70: 50 ton high capacity - 75°F ambient air temperature**

CFM	EWB (°F)	95°F EDB			90°F EDB			85°F EDB			80°F EDB			75°F EDB			70°F EDB			65°F EDB		
		TMBH	SMBH	kW	TMBH	SMBH	kW	TMBH	SMBH	kW	TMBH	SMBH	kW	TMBH	SMBH	kW	TMBH	SMBH	kW	TMBH	SMBH	kW
8,000	77	671	366	43	672	322	43	672	279	43	672	235	43	-	-	-	-	-	-	-	-	-
	72	610	410	42	609	366	42	610	323	42	610	280	42	610	236	42	-	-	-	-	-	-
	67	-	-	-	-	-	-	-	-	-	-	-	-	-	-	-	-	-	-	-	-	-
	62	-	-	-	-	-	-	-	-	-	-	-	-	-	-	-	-	-	-	-	-	-
	57	-	-	-	-	-	-	-	-	-	-	-	-	-	-	-	-	-	-	-	-	-
11,000	77	746	440	44	746	380	44	746	320	44	744	259	44	-	-	-	-	-	-	-	-	-
	72	681	501	43	681	442	43	681	382	43	681	322	43	680	262	43	-	-	-	-	-	-
	67	624	562	42	621	502	42	620	442	42	620	383	42	620	323	42	620	263	42	-	-	-
	62	-	-	-	-	-	-	-	-	-	-	-	-	-	-	-	-	-	-	-	-	-
	57	-	-	-	-	-	-	-	-	-	-	-	-	-	-	-	-	-	-	-	-	-
14,000	77	792	508	45	792	432	45	791	355	45	788	277	45	-	-	-	-	-	-	-	-	-
	72	728	586	44	725	510	44	725	434	44	724	358	44	722	280	44	-	-	-	-	-	-
	67	676	665	43	667	588	43	663	511	43	662	435	43	662	359	43	660	282	43	-	-	-
	62	672	672	43	638	638	42	612	589	42	606	512	42	604	436	42	604	360	42	602	283	42
	57	670	670	43	637	637	42	604	604	42	-	-	-	-	-	-	-	-	-	-	-	-
17,000	77	824	572	45	822	479	45	819	386	45	818	292	45	-	-	-	-	-	-	-	-	-
	72	762	668	44	757	575	44	755	482	44	753	389	44	751	296	44	-	-	-	-	-	-
	67	732	732	44	703	670	43	695	577	43	692	484	43	690	391	43	688	298	43	-	-	-
	62	730	730	44	693	693	43	657	657	43	637	578	42	633	485	42	631	392	42	629	299	42
	57	729	729	44	692	692	43	655	655	43	620	620	42	-	-	-	-	-	-	-	-	-
20,000	77	-	-	-	-	-	-	-	-	-	-	-	-	-	-	-	-	-	-	-	-	-
	72	792	748	45	782	638	45	777	528	44	773	418	44	771	309	44	-	-	-	-	-	-
	67	780	780	45	739	739	44	720	640	44	713	531	43	709	421	43	708	312	43	-	-	-
	62	778	778	45	738	738	44	698	698	43	664	642	43	654	532	42	650	423	42	648	313	42
	57	777	777	44	736	736	44	697	697	43	658	658	43	620	620	42	599	532	42	595	423	42

**Table 71: 50 ton high capacity - 85°F ambient air temperature**

CFM	EWB (°F)	95°F EDB			90°F EDB			85°F EDB			80°F EDB			75°F EDB			70°F EDB			65°F EDB		
		TMBH	SMBH	kW	TMBH	SMBH	kW	TMBH	SMBH	kW	TMBH	SMBH	kW	TMBH	SMBH	kW	TMBH	SMBH	kW	TMBH	SMBH	kW
8,000	77	646	353	47	646	309	47	646	266	47	647	222	47	-	-	-	-	-	-	-	-	-
	72	587	397	46	586	354	46	587	311	46	587	267	46	587	224	46	-	-	-	-	-	-
	67	-	-	-	-	-	-	-	-	-	-	-	-	-	-	-	-	-	-	-	-	-
	62	-	-	-	-	-	-	-	-	-	-	-	-	-	-	-	-	-	-	-	-	-
	57	-	-	-	-	-	-	-	-	-	-	-	-	-	-	-	-	-	-	-	-	-
11,000	77	716	426	48	716	367	48	715	306	48	714	245	48	-	-	-	-	-	-	-	-	-
	72	653	488	47	653	428	47	653	369	47	653	309	47	651	248	47	-	-	-	-	-	-
	67	600	550	46	596	489	46	596	430	46	596	371	46	596	311	46	594	250	46	-	-	-
	62	577	577	46	-	-	-	-	-	-	-	-	-	-	-	-	-	-	-	-	-	-
	57	575	575	46	-	-	-	-	-	-	-	-	-	-	-	-	-	-	-	-	-	-
14,000	77	759	493	48	758	417	48	756	340	48	755	263	48	-	-	-	-	-	-	-	-	-
	72	698	572	47	695	496	47	694	420	47	693	343	47	691	266	47	-	-	-	-	-	-
	67	651	650	47	640	575	46	636	498	46	635	422	46	634	346	46	632	269	46	-	-	-
	62	648	648	47	616	616	46	587	574	46	580	497	46	578	421	46	577	345	46	575	268	45
	57	646	646	47	614	614	46	582	582	46	-	-	-	-	-	-	-	-	-	-	-	-
17,000	77	-	-	-	-	-	-	-	-	-	-	-	-	-	-	-	-	-	-	-	-	-
	72	731	654	48	725	560	48	722	467	48	719	374	48	718	281	48	-	-	-	-	-	-
	67	708	708	48	675	657	47	666	563	47	662	470	47	660	377	47	658	284	47	-	-	-
	62	705	705	48	669	669	47	633	633	46	610	563	46	604	470	46	602	377	46	600	284	46
	57	703	703	47	667	667	47	631	631	46	596	596	46	561	561	45	551	469	45	549	376	45
20,000	77	-	-	-	-	-	-	-	-	-	-	-	-	-	-	-	-	-	-	-	-	-
	72	760	733	48	748	623	48	742	514	48	738	404	48	736	294	48	-	-	-	-	-	-
	67	754	754	48	714	714	48	689	627	47	682	516	47	678	407	47	676	297	47	-	-	-
	62	751	751	48	711	711	48	672	672	47	636	626	46	624	517	46	619	407	46	618	298	46
	57	749	749	48	710	710	48	671	671	47	633	633	46	595	595	46	571	517	45	565	406	45

**Table 72: 50 ton high capacity - 95°F ambient air temperature**

CFM	EWB (°F)	95°F EDB			90°F EDB			85°F EDB			80°F EDB			75°F EDB			70°F EDB			65°F EDB		
		TMBH	SMBH	kW	TMBH	SMBH	kW	TMBH	SMBH	kW	TMBH	SMBH	kW	TMBH	SMBH	kW	TMBH	SMBH	kW	TMBH	SMBH	kW
8,000	77	618	339	51	618	296	51	618	252	51	619	208	51	-	-	-	-	-	-	-	-	-
	72	561	385	50	562	342	50	562	298	50	562	255	50	563	211	50	-	-	-	-	-	-
	67	-	-	-	-	-	-	-	-	-	-	-	-	-	-	-	-	-	-	-	-	-
	62	-	-	-	-	-	-	-	-	-	-	-	-	-	-	-	-	-	-	-	-	-
	57	-	-	-	-	-	-	-	-	-	-	-	-	-	-	-	-	-	-	-	-	-
11,000	77	683	412	52	683	352	52	682	292	52	681	231	52	-	-	-	-	-	-	-	-	-
	72	624	474	51	624	415	51	624	355	51	624	295	51	622	235	51	-	-	-	-	-	-
	67	574	537	50	570	477	50	569	417	50	569	358	50	569	298	50	568	237	50	-	-	-
	62	557	557	50	529	529	50	-	-	-	-	-	-	515	355	49	515	296	49	513	235	49
	57	553	553	50	-	-	-	-	-	-	-	-	-	-	-	-	-	-	-	-	-	-
14,000	77	723	478	53	722	402	53	719	325	53	718	248	53	-	-	-	-	-	-	-	-	-
	72	666	558	52	663	482	52	662	405	52	659	328	52	659	252	52	-	-	-	-	-	-
	67	628	628	51	612	561	51	607	484	51	606	408	51	605	332	51	603	255	51	-	-	-
	62	624	624	51	592	592	51	561	559	50	552	483	50	550	406	50	549	331	50	547	254	50
	57	621	621	51	589	589	50	557	557	50	526	526	50	-	-	-	-	-	-	-	-	-
17,000	77	-	-	-	-	-	-	-	-	-	-	-	-	-	-	-	-	-	-	-	-	-
	72	698	639	52	690	546	52	687	453	52	684	359	52	682	266	52	-	-	-	-	-	-
	67	682	682	52	646	642	51	635	549	51	630	456	51	627	363	51	626	270	51	-	-	-
	62	678	678	52	642	642	51	607	607	51	581	548	50	574	455	50	571	362	50	570	269	50
	57	675	675	52	640	640	51	604	604	51	570	570	50	536	536	50	522	453	49	519	359	49
20,000	77	-	-	-	-	-	-	-	-	-	-	-	-	-	-	-	-	-	-	-	-	-
	72	727	717	53	712	609	53	706	499	52	702	389	52	698	278	52	-	-	-	-	-	-
	67	725	725	53	686	686	52	657	612	52	649	502	51	645	392	51	641	282	51	-	-	-
	62	722	722	53	683	683	52	645	645	51	607	607	51	593	501	50	588	391	50	585	282	50
	57	719	719	53	680	680	52	642	642	51	605	605	51	568	568	50	541	500	50	534	389	50

**Table 73: 50 ton high capacity - 105°F ambient air temperature**

CFM	EWB (°F)	95°F EDB			90°F EDB			85°F EDB			80°F EDB			75°F EDB			70°F EDB			65°F EDB		
		TMBH	SMBH	kW	TMBH	SMBH	kW	TMBH	SMBH	kW	TMBH	SMBH	kW	TMBH	SMBH	kW	TMBH	SMBH	kW	TMBH	SMBH	kW
8,000	77	587	324	56	587	281	56	587	237	56	587	193	56	-	-	-	-	-	-	-	-	-
	72	531	368	55	531	325	55	532	282	55	532	238	55	532	195	55	-	-	-	-	-	-
	67	482	412	54	481	369	54	481	326	54	482	283	54	482	240	54	482	196	54	-	-	-
	62	-	-	-	-	-	-	-	-	-	-	-	-	-	-	-	-	-	-	-	-	-
	57	-	-	-	-	-	-	-	-	-	-	-	-	-	-	-	-	-	-	-	-	-
11,000	77	647	396	57	646	336	57	645	275	57	644	215	57	-	-	-	-	-	-	-	-	-
	72	590	457	56	589	397	56	589	338	56	588	278	56	587	217	56	-	-	-	-	-	-
	67	541	519	55	537	459	55	536	399	55	536	340	55	536	280	55	534	219	55	-	-	-
	62	531	531	55	503	503	55	487	457	54	484	397	54	484	337	54	484	278	54	482	217	54
	57	529	529	55	501	501	55	-	-	-	-	-	-	-	-	-	-	-	-	-	-	-
14,000	77	-	-	-	-	-	-	-	-	-	-	-	-	-	-	-	-	-	-	-	-	-
	72	628	540	57	625	464	57	624	388	57	621	311	57	620	234	57	-	-	-	-	-	-
	67	598	598	56	577	543	56	571	466	56	569	390	56	568	313	56	566	237	56	-	-	-
	62	595	595	56	564	564	56	532	532	55	519	465	55	516	388	55	515	312	55	514	235	55
	57	593	593	56	562	562	56	531	531	55	500	500	55	-	-	-	-	-	-	-	-	-
17,000	77	-	-	-	-	-	-	-	-	-	-	-	-	-	-	-	-	-	-	-	-	-
	72	659	622	57	651	528	57	647	435	57	644	341	57	641	248	57	-	-	-	-	-	-
	67	649	649	57	614	614	56	597	530	56	593	437	56	589	344	56	586	250	56	-	-	-
	62	646	646	57	611	611	56	577	577	56	546	530	55	539	436	55	536	343	55	533	250	55
	57	645	645	57	609	609	56	575	575	56	541	541	55	508	508	55	490	435	54	486	341	54
20,000	77	-	-	-	-	-	-	-	-	-	-	-	-	-	-	-	-	-	-	-	-	-
	72	-	-	-	672	591	58	664	481	57	660	371	57	656	260	57	-	-	-	-	-	-
	67	-	-	-	652	652	57	620	593	57	610	483	56	605	373	56	601	263	56	-	-	-
	62	-	-	-	649	649	57	612	612	56	575	575	56	557	483	55	551	373	55	548	263	55
	57	-	-	-	648	648	57	610	610	56	574	574	56	538	538	55	508	482	55	501	371	55

**Table 74: 50 ton high capacity - 115°F ambient air temperature**

CFM	EWB (°F)	95°F EDB			90°F EDB			85°F EDB			80°F EDB			75°F EDB			70°F EDB			65°F EDB		
		TMBH	SMBH	kW	TMBH	SMBH	kW	TMBH	SMBH	kW	TMBH	SMBH	kW	TMBH	SMBH	kW	TMBH	SMBH	kW	TMBH	SMBH	kW
8,000	77	552	308	62	552	265	62	552	221	62	551	177	62	-	-	-	-	-	-	-	-	-
	72	498	351	61	498	308	61	499	265	61	499	221	61	498	177	61	-	-	-	-	-	-
	67	450	394	60	449	350	60	449	307	60	449	264	60	450	221	60	449	177	60	-	-	-
	62	-	-	-	-	-	-	-	-	-	-	-	-	-	-	-	-	-	-	-	-	-
	57	-	-	-	-	-	-	-	-	-	-	-	-	-	-	-	-	-	-	-	-	-
11,000	77	606	379	63	606	319	63	604	259	63	604	198	63	-	-	-	-	-	-	-	-	-
	72	552	439	62	551	380	62	551	320	62	549	260	62	549	199	62	-	-	-	-	-	-
	67	506	499	61	501	439	61	499	379	61	499	320	61	498	260	61	497	200	61	-	-	-
	62	502	502	61	475	475	61	454	438	60	451	378	60	451	319	60	450	259	60	440	196	60
	57	501	501	61	474	474	61	448	448	60	-	-	-	-	-	-	-	-	-	-	-	-
14,000	77	-	-	-	-	-	-	-	-	-	-	-	-	-	-	-	-	-	-	-	-	-
	72	588	522	63	584	446	62	582	369	62	580	293	62	577	215	62	-	-	-	-	-	-
	67	565	565	62	538	523	62	532	446	61	529	370	61	527	293	61	525	216	61	-	-	-
	62	564	564	62	533	533	61	502	502	61	484	446	61	480	369	61	478	293	61	477	216	60
	57	562	562	62	531	531	61	501	501	61	471	471	60	442	442	60	434	368	60	432	291	60
17,000	77	-	-	-	-	-	-	-	-	-	-	-	-	-	-	-	-	-	-	-	-	-
	72	-	-	-	608	510	63	603	416	63	600	323	63	597	229	63	-	-	-	-	-	-
	67	613	613	63	578	578	62	556	510	62	550	417	62	547	324	62	544	230	62	-	-	-
	62	612	612	63	577	577	62	543	543	62	511	509	61	501	417	61	497	324	61	495	230	61
	57	610	610	63	576	576	62	542	542	62	509	509	61	477	477	60	455	416	60	450	322	60
20,000	77	-	-	-	-	-	-	-	-	-	-	-	-	-	-	-	-	-	-	-	-	-
	72	-	-	-	-	-	-	618	461	63	615	352	63	610	241	63	-	-	-	-	-	-
	67	-	-	-	614	614	63	578	572	62	566	463	62	562	353	62	558	243	62	-	-	-
	62	-	-	-	613	613	63	576	576	62	540	540	62	517	463	61	511	353	61	508	243	61
	57	-	-	-	612	612	63	575	575	62	539	539	62	505	505	61	472	462	60	464	352	60

**Table 75: 50 ton high capacity - 125°F ambient air temperature**

CFM	EWB (°F)	95°F EDB			90°F EDB			85°F EDB			80°F EDB			75°F EDB			70°F EDB			65°F EDB		
		TMBH	SMBH	kW	TMBH	SMBH	kW	TMBH	SMBH	kW	TMBH	SMBH	kW	TMBH	SMBH	kW	TMBH	SMBH	kW	TMBH	SMBH	kW
8,000	77	-	-	-	-	-	-	-	-	-	-	-	-	-	-	-	-	-	-	-	-	-
	72	462	334	68	462	291	68	463	248	68	462	204	68	462	160	68	-	-	-	-	-	-
	67	416	376	67	416	333	67	416	290	67	416	247	67	416	203	67	415	159	67	-	-	-
	62	397	397	66	-	-	-	-	-	-	-	-	-	-	-	-	-	-	-	-	-	-
	57	395	395	66	-	-	-	-	-	-	-	-	-	-	-	-	-	-	-	-	-	-
11,000	77	-	-	-	-	-	-	-	-	-	-	-	-	-	-	-	-	-	-	-	-	-
	72	510	421	68	509	361	68	509	301	68	507	241	68	506	181	68	-	-	-	-	-	-
	67	473	473	68	463	420	68	460	361	68	460	301	67	459	241	67	458	181	67	-	-	-
	62	472	472	68	446	446	67	420	419	67	415	359	67	414	300	67	413	240	67	404	177	67
	57	471	471	68	445	445	67	419	419	67	393	393	66	-	-	-	-	-	-	-	-	-
14,000	77	-	-	-	-	-	-	-	-	-	-	-	-	-	-	-	-	-	-	-	-	-
	72	-	-	-	-	-	-	-	-	-	-	-	-	-	-	-	-	-	-	-	-	-
	67	-	-	-	500	500	68	490	427	68	487	350	68	485	274	68	483	197	68	-	-	-
	62	-	-	-	499	499	68	469	469	68	445	426	67	441	349	67	438	273	67	436	196	67
	57	-	-	-	497	497	68	468	468	68	439	439	67	410	410	67	398	348	66	395	271	66
17,000	77	-	-	-	-	-	-	-	-	-	-	-	-	-	-	-	-	-	-	-	-	-
	72	-	-	-	-	-	-	-	-	-	-	-	-	-	-	-	-	-	-	-	-	-
	67	-	-	-	-	-	-	513	490	68	505	397	68	503	304	68	499	210	68	-	-	-
	62	-	-	-	-	-	-	507	507	68	475	475	68	459	396	67	455	303	67	453	210	67
	57	-	-	-	-	-	-	506	506	68	474	474	68	442	442	67	417	395	67	411	302	67
20,000	77	-	-	-	-	-	-	-	-	-	-	-	-	-	-	-	-	-	-	-	-	-
	72	-	-	-	-	-	-	-	-	-	-	-	-	-	-	-	-	-	-	-	-	-
	67	-	-	-	-	-	-	-	-	-	520	442	69	515	333	68	510	222	68	-	-	-
	62	-	-	-	-	-	-	-	-	-	502	502	68	474	442	68	468	332	68	463	222	67
	57	-	-	-	-	-	-	-	-	-	501	501	68	467	467	68	434	434	67	423	331	67

**Notes:**

Rated performance is at sea level. Cooling capacities are gross cooling capacities.  
 CFM = airflow, EWB = entering wet bulb air, EDB = entering dry bulb air, TMBH = total cooling capacity (MBH)  
 SMBH = sensible cooling capacity (MBH), kW = total input

## Cooling performance data 60 ton standard efficiency

**Table 76: 60 ton standard efficiency - 75°F ambient air temperature**

CFM	EWB (°F)	95°F EDB			90°F EDB			85°F EDB			80°F EDB			75°F EDB			70°F EDB			65°F EDB		
		TMBH	SMBH	kW	TMBH	SMBH	kW	TMBH	SMBH	kW	TMBH	SMBH	kW	TMBH	SMBH	kW	TMBH	SMBH	kW	TMBH	SMBH	kW
12,000	77	806	481	46	807	421	46	807	363	46	807	305	46	-	-	-	-	-	-	-	-	-
	72	743	540	46	744	482	46	744	423	46	744	365	46	730	319	46	-	-	-	-	-	-
	67	680	600	45	680	543	45	681	482	45	680	425	45	680	367	45	680	306	45	-	-	-
	62	639	639	45	622	602	45	623	542	45	623	484	45	623	426	45	622	369	45	623	305	45
	57	639	639	45	612	612	44	-	-	-	-	-	-	-	-	-	-	-	-	-	-	-
15,000	77	850	538	47	851	461	47	851	386	47	851	315	47	-	-	-	-	-	-	-	-	-
	72	785	612	46	786	537	46	786	464	46	786	391	46	773	336	46	-	-	-	-	-	-
	67	720	687	46	721	613	46	721	542	46	721	467	46	721	395	46	721	325	46	-	-	-
	62	703	703	45	672	672	45	661	615	45	662	541	45	662	469	45	662	400	45	662	324	45
	57	703	703	45	671	671	45	640	640	45	610	610	45	-	-	-	-	-	-	-	-	-
19,000	77	890	605	47	890	516	47	891	428	47	891	330	47	-	-	-	-	-	-	-	-	-
	72	831	689	47	825	611	47	825	522	47	825	427	47	812	355	47	-	-	-	-	-	-
	67	772	772	46	759	706	46	760	616	46	760	524	46	760	433	46	760	342	46	-	-	-
	62	771	771	46	736	736	46	701	701	45	698	615	46	698	524	46	698	433	46	698	342	46
	57	771	771	46	735	735	46	700	700	45	666	666	45	640	614	45	641	526	45	641	436	45
21,000	77	904	636	47	904	539	47	904	441	47	905	342	47	-	-	-	-	-	-	-	-	-
	72	851	717	47	838	644	47	839	543	47	839	444	47	826	364	47	-	-	-	-	-	-
	67	799	799	46	771	748	46	774	645	46	774	546	46	773	447	46	773	348	46	-	-	-
	62	798	798	46	761	761	46	725	725	46	712	649	46	712	551	46	712	453	46	711	348	46
	57	798	798	46	761	761	46	724	724	46	688	688	45	654	649	46	653	551	45	653	450	45
24,000	77	921	691	47	922	572	47	922	461	47	923	351	48	-	-	-	-	-	-	-	-	-
	72	878	762	47	859	684	47	856	578	47	856	467	47	842	380	47	-	-	-	-	-	-
	67	834	834	47	796	796	46	790	695	46	789	584	46	789	473	47	789	363	47	-	-	-
	62	834	834	47	795	795	46	756	756	46	728	699	46	730	591	46	729	474	46	728	364	46
	57	833	833	47	795	795	46	756	756	46	718	718	46	680	680	45	670	589	45	669	475	45

**Table 77: 60 ton standard efficiency - 85°F ambient air temperature**

CFM	EWB (°F)	95°F EDB			90°F EDB			85°F EDB			80°F EDB			75°F EDB			70°F EDB			65°F EDB		
		TMBH	SMBH	kW	TMBH	SMBH	kW	TMBH	SMBH	kW	TMBH	SMBH	kW	TMBH	SMBH	kW	TMBH	SMBH	kW	TMBH	SMBH	kW
12,000	77	776	464	51	776	407	52	776	351	52	776	287	52	-	-	-	-	-	-	-	-	-
	72	715	527	51	716	469	51	716	411	51	716	349	51	703	304	51	-	-	-	-	-	-
	67	654	590	50	655	531	50	655	471	50	655	410	50	655	355	50	655	295	50	-	-	-
	62	621	621	49	599	590	49	599	529	49	600	473	49	600	411	49	599	355	49	600	294	49
	57	620	620	49	593	593	49	-	-	-	-	-	-	-	-	-	-	-	-	-	-	-
15,000	77	816	524	52	816	448	52	817	379	52	817	302	52	-	-	-	-	-	-	-	-	-
	72	754	598	51	754	525	51	754	453	51	755	379	51	742	322	51	-	-	-	-	-	-
	67	692	671	50	692	602	51	692	528	51	693	456	51	693	384	51	693	312	51	-	-	-
	62	682	682	50	651	651	50	634	603	50	636	532	50	636	457	50	636	384	50	636	311	50
	57	681	681	50	651	651	50	620	620	50	590	590	49	583	530	49	583	455	49	583	385	49
19,000	77	852	588	52	853	503	52	853	410	52	853	324	53	-	-	-	-	-	-	-	-	-
	72	799	667	52	789	596	52	791	503	52	791	417	52	778	340	52	-	-	-	-	-	-
	67	746	746	51	726	690	51	728	597	51	728	510	51	728	415	51	728	328	51	-	-	-
	62	746	746	51	711	711	51	677	677	50	669	602	50	669	509	50	669	421	50	669	328	50
	57	745	745	51	711	711	51	677	677	50	643	643	50	612	606	50	614	510	50	614	424	50
21,000	77	865	624	53	865	524	53	865	429	53	866	329	53	-	-	-	-	-	-	-	-	-
	72	818	698	52	802	628	52	803	530	52	803	433	52	790	351	52	-	-	-	-	-	-
	67	772	772	51	739	731	51	741	631	51	741	537	51	740	434	51	740	333	51	-	-	-
	62	771	771	51	735	735	51	700	700	51	680	640	50	682	535	51	681	435	51	681	339	51
	57	771	771	51	735	735	51	699	699	51	664	664	50	630	629	50	625	534	50	625	437	50
24,000	77	880	669	53	882	564	53	882	450	53	882	335	53	-	-	-	-	-	-	-	-	-
	72	843	737	52	825	666	52	819	565	52	819	451	52	806	367	52	-	-	-	-	-	-
	67	806	806	52	768	768	51	755	680	51	756	567	51	755	461	52	755	347	52	-	-	-
	62	805	805	52	767	767	51	730	730	51	695	688	51	697	572	51	697	460	51	697	348	51
	57	805	805	52	767	767	51	729	729	51	692	692	51	656	656	50	640	576	50	640	461	50

**Table 78: 60 ton standard efficiency - 95°F ambient air temperature**

CFM	EWB (°F)	95°F EDB			90°F EDB			85°F EDB			80°F EDB			75°F EDB			70°F EDB			65°F EDB		
		TMBH	SMBH	kW	TMBH	SMBH	kW	TMBH	SMBH	kW	TMBH	SMBH	kW	TMBH	SMBH	kW	TMBH	SMBH	kW	TMBH	SMBH	kW
12,000	77	742	451	57	742	396	57	742	336	57	743	275	57	-	-	-	-	-	-	-	-	-
	72	683	514	56	684	455	56	685	396	56	685	337	56	673	291	56	-	-	-	-	-	-
	67	625	577	55	627	514	55	627	457	55	627	399	55	627	340	55	627	282	55	-	-	-
	62	601	601	55	575	575	54	573	517	54	574	459	54	574	400	54	574	340	54	574	281	54
	57	600	600	55	573	573	54	547	547	54	-	-	-	-	-	-	-	-	-	-	-	-
15,000	77	778	508	57	779	435	57	779	361	57	779	288	58	-	-	-	-	-	-	-	-	-
	72	721	580	57	720	509	57	720	437	57	720	365	57	708	309	56	-	-	-	-	-	-
	67	663	651	56	661	584	56	661	513	56	661	442	56	661	369	56	661	298	56	-	-	-
	62	658	658	55	628	628	55	606	588	55	607	516	55	607	445	55	607	369	55	607	297	55
	57	658	658	55	628	628	55	598	598	55	568	568	54	554	516	54	557	443	54	556	372	54
19,000	77	811	576	58	812	487	58	812	398	58	812	309	58	-	-	-	-	-	-	-	-	-
	72	765	647	57	751	582	57	753	490	57	753	401	57	741	327	57	-	-	-	-	-	-
	67	719	719	56	690	676	56	694	583	56	694	493	56	693	402	56	694	312	56	-	-	-
	62	718	718	56	685	685	56	651	651	56	637	586	55	638	497	55	637	408	55	637	312	56
	57	718	718	56	684	684	56	651	651	55	619	619	55	586	586	54	585	497	55	585	404	55
21,000	77	822	610	58	822	513	58	823	410	58	823	313	58	-	-	-	-	-	-	-	-	-
	72	782	676	57	765	609	57	764	515	57	764	415	57	752	338	57	-	-	-	-	-	-
	67	742	742	57	708	706	56	704	620	56	705	518	57	705	420	57	705	323	57	-	-	-
	62	742	742	57	707	707	56	673	673	56	647	621	55	649	522	56	649	420	56	648	323	56
	57	741	741	57	706	706	56	672	672	56	638	638	55	604	604	55	595	525	55	595	420	55
24,000	77	836	660	58	838	545	58	838	436	58	838	318	59	-	-	-	-	-	-	-	-	-
	72	805	717	58	787	641	58	777	555	57	778	436	58	766	353	57	-	-	-	-	-	-
	67	773	773	57	737	737	57	717	674	57	719	553	57	718	445	57	718	330	57	-	-	-
	62	773	773	57	736	736	57	700	700	56	664	664	56	663	557	56	663	445	56	662	331	56
	57	773	773	57	736	736	57	700	700	56	664	664	56	629	629	55	608	559	55	609	444	55

**Table 79: 60 ton standard efficiency - 105°F ambient air temperature**

CFM	EWB (°F)	95°F EDB			90°F EDB			85°F EDB			80°F EDB			75°F EDB			70°F EDB			65°F EDB		
		TMBH	SMBH	kW	TMBH	SMBH	kW	TMBH	SMBH	kW	TMBH	SMBH	kW	TMBH	SMBH	kW	TMBH	SMBH	kW	TMBH	SMBH	kW
12,000	77	705	436	63	705	378	63	705	320	63	706	261	63	-	-	-	-	-	-	-	-	-
	72	649	498	62	651	440	62	651	381	62	651	323	62	640	278	61	-	-	-	-	-	-
	67	594	561	60	596	502	61	597	442	61	597	386	61	597	325	61	597	269	61	-	-	-
	62	578	578	60	552	552	60	545	503	60	546	443	60	547	386	60	550	327	60	547	268	60
	57	578	578	60	552	552	60	526	526	59	501	501	59	-	-	-	-	-	-	-	-	-
15,000	77	738	491	63	738	422	63	738	350	63	738	276	63	-	-	-	-	-	-	-	-	-
	72	685	562	62	682	497	62	683	425	62	683	352	62	672	294	62	-	-	-	-	-	-
	67	633	633	61	626	572	61	627	500	61	628	428	61	628	354	61	628	282	61	-	-	-
	62	632	632	61	603	603	61	577	571	60	576	501	60	577	428	60	577	356	60	576	282	60
	57	632	632	61	603	603	61	574	574	60	545	545	60	526	505	59	528	429	59	528	356	59
19,000	77	766	559	64	767	468	64	768	384	64	769	292	64	-	-	-	-	-	-	-	-	-
	72	727	624	63	712	562	63	712	477	63	713	386	63	701	313	63	-	-	-	-	-	-
	67	688	688	62	656	656	62	656	570	62	657	479	62	657	388	62	657	295	62	-	-	-
	62	688	688	62	656	656	62	624	624	61	601	577	61	604	483	61	603	392	61	603	301	61
	57	687	687	62	655	655	62	623	623	61	592	592	61	560	560	60	554	482	60	554	393	60
21,000	77	776	591	64	777	492	64	777	395	64	778	296	64	-	-	-	-	-	-	-	-	-
	72	743	650	63	727	584	63	721	500	63	723	399	63	711	323	63	-	-	-	-	-	-
	67	709	709	63	677	677	62	664	605	62	667	503	62	667	404	62	667	305	62	-	-	-
	62	710	710	63	676	676	62	643	643	62	612	607	61	614	506	61	614	409	61	613	306	61
	57	709	709	63	675	675	62	643	643	61	610	610	61	577	577	60	562	507	60	563	409	60
24,000	77	788	638	64	790	529	64	791	419	64	791	309	64	-	-	-	-	-	-	-	-	-
	72	763	688	64	747	616	63	733	537	63	735	423	63	724	333	63	-	-	-	-	-	-
	67	738	738	63	704	704	63	676	655	62	679	537	62	679	428	62	678	312	63	-	-	-
	62	738	738	63	703	703	63	669	669	62	634	634	61	625	544	61	627	426	61	626	319	62
	57	737	737	63	703	703	63	668	668	62	634	634	61	599	599	61	573	545	60	575	431	60

**Table 80: 60 ton standard efficiency - 115°F ambient air temperature**

CFM	EWB (°F)	95°F EDB			90°F EDB			85°F EDB			80°F EDB			75°F EDB			70°F EDB			65°F EDB		
		TMBH	SMBH	kW	TMBH	SMBH	kW	TMBH	SMBH	kW	TMBH	SMBH	kW	TMBH	SMBH	kW	TMBH	SMBH	kW	TMBH	SMBH	kW
12,000	77	664	424	69	665	363	69	665	307	69	665	246	69	-	-	-	-	-	-	-	-	-
	72	613	484	68	613	427	68	614	368	68	615	308	68	605	262	68	-	-	-	-	-	-
	67	562	545	66	562	490	67	564	428	67	564	370	67	564	312	67	564	254	67	-	-	-
	62	554	554	66	528	528	66	515	490	65	516	433	66	517	370	66	517	312	66	517	253	66
	57	553	553	66	528	528	66	503	503	65	478	478	65	471	433	65	475	374	65	472	313	65
15,000	77	693	476	69	694	404	69	694	332	69	695	260	70	-	-	-	-	-	-	-	-	-
	72	648	540	68	641	481	68	642	408	68	643	335	68	633	278	68	-	-	-	-	-	-
	67	604	604	67	588	557	67	590	484	67	591	409	67	591	336	67	591	266	67	-	-	-
	62	603	603	67	575	575	67	548	548	66	541	489	66	543	411	66	544	341	66	543	266	66
	57	603	603	67	575	575	67	547	547	66	520	520	66	497	485	65	507	421	65	498	340	65
19,000	77	720	547	70	719	453	70	720	593	70	721	274	70	-	-	-	-	-	-	-	-	-
	72	687	601	69	671	538	69	667	463	69	669	368	69	658	297	69	-	-	-	-	-	-
	67	654	654	68	624	624	68	614	558	68	617	463	68	617	370	68	617	284	68	-	-	-
	62	654	654	68	624	624	68	591	591	67	564	559	67	567	465	67	567	374	67	567	283	67
	57	654	654	68	623	623	68	593	593	67	562	562	67	532	532	66	519	467	66	521	375	66
21,000	77	727	574	70	727	480	70	729	383	70	729	283	70	-	-	-	-	-	-	-	-	-
	72	675	675	69	674	586	69	675	487	69	678	384	69	667	303	69	-	-	-	-	-	-
	67	674	674	69	643	643	68	622	591	68	626	484	68	626	385	68	626	288	68	-	-	-
	62	674	674	69	642	642	68	610	610	68	580	578	67	575	490	67	577	390	67	576	288	67
	57	673	673	69	642	642	68	610	610	68	580	580	67	548	548	66	527	495	66	529	389	66
24,000	77	-	-	-	-	-	-	-	-	-	-	-	-	-	-	-	-	-	-	-	-	-
	72	-	-	-	-	-	-	-	-	-	-	-	-	678	315	69	-	-	-	-	-	-
	67	700	700	69	667	667	69	634	634	68	636	521	68	636	407	68	636	299	69	-	-	-
	62	700	700	69	667	667	69	634	634	68	636	601	68	585	532	67	588	411	67	587	299	68
	57	699	699	69	666	666	69	634	634	68	636	601	68	568	568	67	537	531	66	540	415	66

**Table 81: 60 ton standard efficiency - 125°F ambient air temperature**

CFM	EWB (°F)	95°F EDB			90°F EDB			85°F EDB			80°F EDB			75°F EDB			70°F EDB			65°F EDB		
		TMBH	SMBH	kW	TMBH	SMBH	kW	TMBH	SMBH	kW	TMBH	SMBH	kW	TMBH	SMBH	kW	TMBH	SMBH	kW	TMBH	SMBH	kW
12,000	77	621	409	75	622	347	75	622	289	75	627	232	76	-	-	-	-	-	-	-	-	-
	72	574	468	74	573	411	74	574	352	74	577	292	74	566	248	74	-	-	-	-	-	-
	67	527	527	73	525	475	73	526	416	73	528	353	73	529	297	73	529	238	73	-	-	-
	62	526	526	73	502	502	72	483	472	72	482	416	72	487	359	72	485	298	72	485	238	72
	57	526	526	73	502	502	72	478	478	72	454	454	71	441	417	71	442	357	71	454	303	71
15,000	77	646	459	76	646	389	76	647	316	76	647	247	77	-	-	-	-	-	-	-	-	-
	72	609	515	75	599	464	75	598	393	75	606	321	75	590	261	75	-	-	-	-	-	-
	67	572	572	74	551	538	74	549	469	74	552	395	74	552	321	74	552	248	74	-	-	-
	62	572	572	74	545	545	74	519	519	73	505	472	73	516	403	73	508	324	73	508	251	73
	57	571	571	74	545	545	74	518	518	73	492	492	72	466	466	72	463	399	72	465	325	72
19,000	77	-	-	-	668	434	77	669	348	77	670	261	77	-	-	-	-	-	-	-	-	-
	72	-	-	-	628	512	76	620	445	75	622	354	76	612	279	75	-	-	-	-	-	-
	67	618	618	75	589	589	75	570	541	74	573	447	74	574	356	75	574	264	75	-	-	-
	62	617	617	75	588	588	75	560	560	74	531	531	73	527	453	73	529	354	73	528	264	74
	57	617	617	75	588	588	75	559	559	74	530	530	73	502	502	73	502	462	73	485	359	72
21,000	77	-	-	-	-	-	-	-	-	-	-	-	-	-	-	-	-	-	-	-	-	-
	72	636	636	76	624	568	75	628	465	76	629	365	76	620	287	76	-	-	-	-	-	-
	67	635	635	76	606	606	75	577	572	74	582	473	75	582	370	75	582	272	75	-	-	-
	62	635	635	76	605	605	75	575	575	74	546	546	74	533	476	73	536	372	74	536	272	63
	57	635	635	76	605	605	75	575	575	74	545	545	74	516	516	73	494	482	73	492	372	63
24,000	77	-	-	-	-	-	-	-	-	-	-	-	-	-	-	-	-	-	-	-	-	-
	72	-	-	-	-	-	-	-	-	-	-	-	-	630	299	76	-	-	-	-	-	-
	67	659	659	76	627	627	76	596	596	75	588	512	75	591	390	75	591	278	75	-	-	-
	62	658	658	76	627	627	76	596	596	75	565	565	74	543	510	74	546	393	74	546	284	74
	57	658	658	76	627	627	76	596	596	75	565	565	74	534	534	73	503	503	73	501	401	73

**Notes:**

Rated performance is at sea level. Cooling capacities are gross cooling capacities.  
 CFM = airflow, EWB = entering wet bulb air, EDB = entering dry bulb air, TMBH = total cooling capacity (MBH)  
 SMBH = sensible cooling capacity (MBH), kW = total input

## Cooling performance data 60 ton high efficiency

**Table 82: 60 ton high efficiency - 75°F ambient air temperature**

CFM	EWB (°F)	95°F EDB			90°F EDB			85°F EDB			80°F EDB			75°F EDB			70°F EDB			65°F EDB		
		TMBH	SMBH	kW	TMBH	SMBH	kW	TMBH	SMBH	kW	TMBH	SMBH	kW	TMBH	SMBH	kW	TMBH	SMBH	kW	TMBH	SMBH	kW
12,000	77	797	475	44	798	418	44	798	361	44	799	302	44	-	-	-	-	-	-	-	-	-
	72	732	541	44	733	481	44	734	421	44	734	361	44	734	301	44	-	-	-	-	-	-
	67	672	600	43	672	538	43	673	482	43	673	420	44	674	365	44	674	303	44	-	-	-
	62	635	635	43	617	597	43	616	542	43	616	485	43	617	422	43	617	365	43	617	302	43
	57	635	635	43	607	607	43	-	-	-	-	-	-	-	-	-	-	-	-	-	-	-
15,000	77	840	531	45	841	461	45	842	391	45	842	312	45	-	-	-	-	-	-	-	-	-
	72	775	610	44	776	537	44	776	464	44	777	391	44	777	318	44	-	-	-	-	-	-
	67	711	686	44	712	613	44	713	539	44	713	465	44	714	396	44	714	321	44	-	-	-
	62	699	699	44	668	668	43	653	617	43	655	541	43	656	467	44	656	396	44	656	321	44
	57	698	698	44	667	667	43	637	637	43	607	607	43	601	547	43	601	469	43	602	397	43
19,000	77	879	606	45	879	510	45	882	423	45	882	326	45	-	-	-	-	-	-	-	-	-
	72	813	699	44	814	610	45	815	521	45	815	424	45	815	334	45	-	-	-	-	-	-
	67	767	767	44	750	705	44	752	609	44	752	519	44	753	429	44	753	339	44	-	-	-
	62	766	766	44	731	731	44	697	697	44	690	614	44	692	526	44	692	429	44	691	339	44
	57	766	766	44	731	731	44	696	696	44	662	662	43	633	620	43	634	527	43	635	432	44
21,000	77	892	637	45	894	540	45	895	437	45	896	339	45	-	-	-	-	-	-	-	-	-
	72	826	743	45	828	641	45	829	544	45	829	444	45	829	340	45	-	-	-	-	-	-
	67	793	793	44	762	747	44	765	644	44	765	546	44	765	448	44	765	344	45	-	-	-
	62	793	793	44	756	756	44	721	721	44	703	654	44	705	553	44	705	449	44	705	345	44
	57	792	792	44	756	756	44	720	720	44	684	684	44	650	647	43	647	552	44	647	450	44
24,000	77	909	691	45	910	574	45	912	465	45	913	347	45	-	-	-	-	-	-	-	-	-
	72	841	807	45	844	692	45	845	583	45	846	465	45	846	355	45	-	-	-	-	-	-
	67	828	828	44	790	790	44	781	702	44	782	586	45	782	469	45	782	360	45	-	-	-
	62	828	828	44	790	790	44	752	752	44	719	704	44	722	585	44	721	476	44	721	361	44
	57	827	827	44	789	789	44	751	751	44	714	714	44	677	677	44	662	589	44	663	477	44

**Table 83: 60 ton high efficiency - 85°F ambient air temperature**

CFM	EWB (°F)	95°F EDB			90°F EDB			85°F EDB			80°F EDB			75°F EDB			70°F EDB			65°F EDB		
		TMBH	SMBH	kW	TMBH	SMBH	kW	TMBH	SMBH	kW	TMBH	SMBH	kW	TMBH	SMBH	kW	TMBH	SMBH	kW	TMBH	SMBH	kW
12,000	77	768	465	49	768	403	49	769	347	49	769	284	49	-	-	-	-	-	-	-	-	-
	72	705	528	49	706	470	49	706	406	49	707	348	49	707	290	49	-	-	-	-	-	-
	67	646	590	48	647	531	48	648	471	48	649	411	48	649	352	48	649	292	48	-	-	-
	62	618	618	48	595	585	48	593	529	48	593	474	48	594	412	48	594	352	48	594	291	48
	57	617	617	48	590	590	47	564	564	47	-	-	-	-	-	-	-	-	-	-	-	-
15,000	77	808	519	50	808	446	50	809	375	50	809	300	50	-	-	-	-	-	-	-	-	-
	72	744	595	49	745	523	49	746	449	49	746	376	49	747	306	49	-	-	-	-	-	-
	67	685	669	49	684	602	49	685	525	49	686	454	49	686	380	49	686	309	49	-	-	-
	62	678	678	48	648	648	48	628	603	48	629	532	48	630	455	48	630	383	48	630	309	48
	57	678	678	48	647	647	48	617	617	48	587	587	48	576	530	48	577	457	48	577	383	48
19,000	77	843	590	50	844	498	50	845	406	50	846	321	50	-	-	-	-	-	-	-	-	-
	72	779	685	50	780	593	50	781	507	50	781	414	50	782	320	50	-	-	-	-	-	-
	67	742	742	49	717	696	49	720	598	49	721	505	49	722	419	49	722	325	49	-	-	-
	62	742	742	49	707	707	49	674	674	49	662	602	49	663	511	49	663	418	49	662	324	49
	57	741	741	49	707	707	49	673	673	49	640	640	48	606	606	48	608	510	48	608	420	48
21,000	77	855	626	50	857	526	50	858	425	50	859	326	51	-	-	-	-	-	-	-	-	-
	72	790	727	50	793	628	50	794	529	50	794	427	50	795	326	50	-	-	-	-	-	-
	67	767	767	49	734	729	49	732	637	49	734	531	49	734	431	49	734	330	50	-	-	-
	62	767	767	49	731	731	49	696	696	49	673	640	49	675	536	49	675	436	49	675	336	49
	57	766	766	49	731	731	49	695	695	49	661	661	48	626	626	48	619	540	48	619	437	48
24,000	77	-	-	-	-	-	-	-	-	-	-	-	-	-	-	-	-	-	-	-	-	-
	72	805	797	50	808	679	50	809	566	50	809	453	50	810	340	50	-	-	-	-	-	-
	67	801	801	50	763	763	49	746	686	49	748	569	50	749	457	50	749	345	50	-	-	-
	62	801	801	50	763	763	49	726	726	49	691	691	49	699	580	49	691	463	49	691	345	49
	57	800	800	50	763	763	49	725	725	49	689	689	49	652	652	48	633	576	48	634	463	49

**Table 84: 60 ton high efficiency - 95°F ambient air temperature**

CFM	EWB (°F)	95°F EDB			90°F EDB			85°F EDB			80°F EDB			75°F EDB			70°F EDB			65°F EDB		
		TMBH	SMBH	kW	TMBH	SMBH	kW	TMBH	SMBH	kW	TMBH	SMBH	kW	TMBH	SMBH	kW	TMBH	SMBH	kW	TMBH	SMBH	kW
12,000	77	734	453	55	735	393	55	736	333	55	736	272	55	-	-	-	-	-	-	-	-	-
	72	675	513	54	676	451	54	677	395	54	678	335	54	678	278	54	-	-	-	-	-	-
	67	619	577	53	620	516	53	621	458	53	622	396	53	622	337	53	622	280	53	-	-	-
	62	597	597	53	571	571	53	568	518	53	568	460	53	569	401	53	569	338	53	569	279	53
	57	597	597	53	570	570	52	544	544	52	-	-	-	-	-	-	-	-	-	-	-	-
15,000	77	771	506	55	772	434	55	773	362	55	774	286	55	-	-	-	-	-	-	-	-	-
	72	710	583	54	712	510	55	713	436	55	713	367	55	714	293	55	-	-	-	-	-	-
	67	658	650	54	653	591	54	654	515	54	656	441	54	656	366	54	656	295	54	-	-	-
	62	655	655	54	625	625	53	602	588	53	601	517	53	602	441	53	602	370	53	602	295	53
	57	654	654	54	625	625	53	595	595	53	566	566	53	550	517	52	551	444	52	551	368	53
19,000	77	804	579	56	804	483	56	805	395	56	806	306	56	-	-	-	-	-	-	-	-	-
	72	741	675	55	744	580	55	745	491	55	745	402	55	746	306	55	-	-	-	-	-	-
	67	715	715	54	684	677	54	694	590	54	688	495	54	688	399	55	688	310	55	-	-	-
	62	714	714	54	681	681	54	649	649	54	630	592	54	632	493	54	632	405	54	632	310	54
	57	714	714	54	681	681	54	648	648	54	616	616	53	583	583	53	579	498	53	580	406	53
21,000	77	-	-	-	-	-	-	-	-	-	818	311	56	-	-	-	-	-	-	-	-	-
	72	752	720	55	755	613	55	756	517	55	757	415	55	758	317	55	-	-	-	-	-	-
	67	739	739	55	705	703	54	699	622	54	699	520	55	699	417	55	699	320	55	-	-	-
	62	738	738	55	704	704	54	670	670	54	640	627	54	643	522	54	643	422	54	643	320	54
	57	738	738	55	703	703	54	669	669	54	635	635	54	602	602	53	589	525	53	590	422	53
24,000	77	-	-	-	-	-	-	-	-	-	-	-	-	-	-	-	-	-	-	-	-	-
	72	770	770	55	768	668	55	770	554	55	771	439	56	772	324	56	-	-	-	-	-	-
	67	770	770	55	734	734	55	709	674	55	713	556	55	713	442	55	713	328	55	-	-	-
	62	769	769	55	733	733	55	697	697	54	662	662	54	656	564	54	658	447	54	657	329	54
	57	769	769	55	733	733	55	697	697	54	661	661	54	626	626	54	602	566	53	603	447	53

**Table 85: 60 ton high efficiency - 105°F ambient air temperature**

CFM	EWB (°F)	95°F EDB			90°F EDB			85°F EDB			80°F EDB			75°F EDB			70°F EDB			65°F EDB		
		TMBH	SMBH	kW	TMBH	SMBH	kW	TMBH	SMBH	kW	TMBH	SMBH	kW	TMBH	SMBH	kW	TMBH	SMBH	kW	TMBH	SMBH	kW
12,000	77	699	439	60	700	381	60	701	318	61	702	260	61	-	-	-	-	-	-	-	-	-
	72	642	501	59	644	443	60	644	383	60	645	324	60	645	265	60	-	-	-	-	-	-
	67	590	562	59	590	503	59	591	443	59	592	383	59	592	327	59	592	267	59	-	-	-
	62	576	576	58	550	550	58	540	504	58	541	444	58	542	388	58	542	326	58	542	266	58
	57	575	575	58	549	549	58	524	524	58	498	498	57	494	445	57	495	385	57	-	-	-
15,000	77	731	495	61	733	419	61	734	348	61	735	275	61	-	-	-	-	-	-	-	-	-
	72	674	569	60	676	498	60	677	421	60	678	351	60	678	278	60	-	-	-	-	-	-
	67	630	630	59	620	573	59	621	501	59	623	425	59	623	354	59	623	281	60	-	-	-
	62	629	629	59	601	601	59	574	567	58	570	502	58	571	430	59	572	354	59	572	280	59
	57	629	629	59	600	600	59	571	571	58	543	543	58	522	502	58	523	430	58	524	355	58
19,000	77	-	-	-	-	-	-	-	-	-	764	290	62	-	-	-	-	-	-	-	-	-
	72	701	659	60	704	570	61	706	473	61	706	381	61	707	297	61	-	-	-	-	-	-
	67	686	686	60	654	654	60	650	572	60	652	482	60	652	385	60	653	294	60	-	-	-
	62	685	685	60	653	653	60	621	621	59	597	579	59	598	485	59	599	389	59	599	300	59
	57	684	684	60	653	653	60	621	621	59	589	589	59	558	558	58	548	482	58	549	390	58
21,000	77	-	-	-	-	-	-	-	-	-	-	-	-	-	-	-	-	-	-	-	-	-
	72	711	703	61	714	601	61	716	503	61	717	399	61	718	301	61	-	-	-	-	-	-
	67	707	707	60	674	674	60	659	606	60	662	506	60	662	401	60	662	303	60	-	-	-
	62	707	707	60	674	674	60	641	641	60	609	606	59	608	507	59	609	406	59	609	305	60
	57	706	706	60	673	673	60	641	641	60	608	608	59	575	575	59	557	512	58	559	406	59
24,000	77	-	-	-	-	-	-	-	-	-	-	-	-	-	-	-	-	-	-	-	-	-
	72	736	736	61	725	652	61	728	539	61	729	423	61	729	314	61	-	-	-	-	-	-
	67	737	737	61	702	702	60	670	663	60	673	539	60	674	425	60	674	310	61	-	-	-
	62	736	736	61	701	701	60	666	666	60	632	632	60	622	547	60	622	429	60	622	317	60
	57	735	735	61	701	701	60	666	666	60	632	632	60	597	597	59	569	551	59	571	428	59

**Table 86: 60 ton high efficiency - 115°F ambient air temperature**

CFM	EWB (°F)	95°F EDB			90°F EDB			85°F EDB			80°F EDB			75°F EDB			70°F EDB			65°F EDB		
		TMBH	SMBH	kW	TMBH	SMBH	kW	TMBH	SMBH	kW	TMBH	SMBH	kW	TMBH	SMBH	kW	TMBH	SMBH	kW	TMBH	SMBH	kW
12,000	77	660	423	66	661	366	67	662	306	67	663	245	67	-	-	-	-	-	-	-	-	-
	72	607	487	65	608	426	66	609	369	66	610	308	66	610	250	66	-	-	-	-	-	-
	67	559	545	65	558	488	65	559	431	65	559	373	65	560	311	65	561	252	65	-	-	-
	62	552	552	64	527	527	64	512	487	64	512	430	64	513	372	64	513	310	64	513	252	64
	57	551	551	64	526	526	64	501	501	63	476	476	63	467	431	63	468	369	63	469	311	63
15,000	77	689	480	67	690	402	67	692	331	67	693	259	67	-	-	-	-	-	-	-	-	-
	72	634	557	66	636	484	66	638	410	66	640	338	66	640	262	66	-	-	-	-	-	-
	67	602	602	65	585	558	65	586	486	65	587	412	65	588	340	65	588	265	66	-	-	-
	62	602	602	65	574	574	65	546	546	64	537	486	64	539	413	64	540	339	65	540	265	65
	57	601	601	65	573	573	65	546	546	64	518	518	64	494	485	63	493	415	64	494	340	64
19,000	77	-	-	-	-	-	-	-	-	-	-	-	-	-	-	-	-	-	-	-	-	-
	72	658	645	66	661	555	67	664	458	67	664	372	67	665	279	67	-	-	-	-	-	-
	67	653	653	66	623	623	66	610	561	66	611	464	66	614	375	66	614	282	66	-	-	-
	62	653	653	66	622	622	66	592	592	65	562	562	65	563	467	65	564	372	65	564	282	65
	57	652	652	66	622	622	66	591	591	65	561	561	65	531	531	64	515	469	64	517	377	64
21,000	77	-	-	-	-	-	-	-	-	-	-	-	-	-	-	-	-	-	-	-	-	-
	72	673	670	67	669	589	67	673	486	67	674	383	67	674	283	67	-	-	-	-	-	-
	67	673	673	67	642	642	66	618	593	66	621	492	66	623	390	66	622	286	66	-	-	-
	62	673	673	67	641	641	66	609	609	66	578	578	65	572	493	65	573	387	65	573	291	66
	57	672	672	67	641	641	66	609	609	66	577	577	65	546	546	65	523	497	64	525	392	64
24,000	77	-	-	-	-	-	-	-	-	-	-	-	-	-	-	-	-	-	-	-	-	-
	72	-	-	-	677	636	67	683	519	67	684	410	67	685	295	68	-	-	-	-	-	-
	67	-	-	-	666	666	67	633	633	66	631	530	66	633	411	66	634	298	67	-	-	-
	62	-	-	-	666	666	67	633	633	66	600	600	65	581	534	65	584	415	66	584	298	66
	57	-	-	-	665	665	67	632	632	66	599	599	66	567	567	65	534	534	64	535	417	65

**Table 87: 60 ton high efficiency - 125°F ambient air temperature**

CFM	EWB (°F)	95°F EDB			90°F EDB			85°F EDB			80°F EDB			75°F EDB			70°F EDB			65°F EDB		
		TMBH	SMBH	kW	TMBH	SMBH	kW	TMBH	SMBH	kW	TMBH	SMBH	kW	TMBH	SMBH	kW	TMBH	SMBH	kW	TMBH	SMBH	kW
12,000	77	618	408	73	619	351	73	621	293	73	621	231	73	-	-	-	-	-	-	-	-	-
	72	568	473	72	569	411	72	571	353	72	572	294	72	576	236	72	-	-	-	-	-	-
	67	526	526	71	522	473	71	524	415	71	525	356	71	526	297	71	526	237	71	-	-	-
	62	525	525	71	501	501	70	481	473	70	480	419	70	481	355	70	482	296	70	482	236	70
	57	525	525	71	501	501	70	477	477	70	453	453	69	439	414	69	439	356	69	440	297	69
15,000	77	-	-	-	-	-	-	-	-	-	-	-	-	-	-	-	-	-	-	-	-	-
	72	592	540	72	594	470	72	596	395	73	598	322	73	599	248	73	-	-	-	-	-	-
	67	571	571	72	549	539	71	547	473	72	548	398	72	550	323	72	551	248	72	-	-	-
	62	571	571	72	544	544	71	522	511	71	502	474	71	504	398	71	507	324	71	506	250	71
	57	570	570	72	544	544	71	517	517	71	491	491	70	465	465	70	461	400	70	462	325	70
19,000	77	-	-	-	-	-	-	-	-	-	-	-	-	-	-	-	-	-	-	-	-	-
	72	618	618	73	614	541	73	618	445	73	619	353	73	620	261	74	-	-	-	-	-	-
	67	618	618	73	589	589	72	567	544	72	570	451	72	573	355	72	573	264	73	-	-	-
	62	617	617	73	588	588	72	559	559	72	531	531	71	524	450	71	526	358	71	527	263	72
	57	617	617	73	588	588	72	559	559	72	530	530	71	501	501	71	480	456	70	482	361	70
21,000	77	-	-	-	-	-	-	-	-	-	-	-	-	-	-	-	-	-	-	-	-	-
	72	636	636	73	621	571	73	625	470	73	627	368	74	629	269	74	-	-	-	-	-	-
	67	636	636	73	605	605	73	577	572	72	578	475	72	580	369	73	581	272	73	-	-	-
	62	635	635	73	605	605	73	575	575	72	545	545	72	531	478	71	534	376	72	534	271	72
	57	635	635	73	605	605	73	575	575	72	545	545	72	515	515	71	488	479	70	489	375	71
24,000	77	-	-	-	-	-	-	-	-	-	-	-	-	-	-	-	-	-	-	-	-	-
	72	-	-	-	630	623	73	633	507	73	636	388	74	638	274	74	-	-	-	-	-	-
	67	-	-	-	628	628	73	596	596	73	592	515	72	591	396	73	590	277	73	-	-	-
	62	-	-	-	627	627	73	596	596	73	565	565	72	540	518	72	543	396	72	544	283	72
	57	-	-	-	627	627	73	596	596	73	564	564	72	533	533	71	502	502	71	498	404	71

**Notes:**

Rated performance is at sea level. Cooling capacities are gross cooling capacities.  
 CFM = airflow, EWB = entering wet bulb air, EDB = entering dry bulb air, TMBH = total cooling capacity (MBH)  
 SMBH = sensible cooling capacity (MBH), kW = total input

## Cooling performance data 60 ton high capacity

**Table 88: 60 ton high capacity - 75°F ambient air temperature**

CFM	EWB (°F)	95°F EDB			90°F EDB			85°F EDB			80°F EDB			75°F EDB			70°F EDB			65°F EDB		
		TMBH	SMBH	kW	TMBH	SMBH	kW	TMBH	SMBH	kW	TMBH	SMBH	kW	TMBH	SMBH	kW	TMBH	SMBH	kW	TMBH	SMBH	kW
12,000	77	840	493	50	840	432	50	841	372	50	841	318	50	-	-	-	-	-	-	-	-	-
	72	773	555	49	773	498	49	775	437	49	775	380	49	774	317	49	-	-	-	-	-	-
	67	709	617	48	710	559	48	710	502	48	711	442	48	711	378	48	711	320	48	-	-	-
	62	663	663	48	651	618	47	651	560	47	652	502	48	652	443	48	652	385	48	653	320	48
	57	663	663	48	-	-	-	-	-	-	-	-	-	-	-	-	-	-	-	-	-	-
15,000	77	888	552	50	889	478	50	890	404	50	890	329	50	-	-	-	-	-	-	-	-	-
	72	820	628	49	820	551	49	821	483	49	821	406	50	822	337	50	-	-	-	-	-	-
	67	753	703	49	754	631	49	755	561	49	755	485	49	756	411	49	756	340	49	-	-	-
	62	730	730	48	699	699	48	693	638	48	694	560	48	695	488	48	695	413	48	695	340	48
	57	730	730	48	699	699	48	668	668	48	-	-	-	-	-	-	-	-	-	-	-	-
19,000	77	932	625	51	932	531	51	934	439	51	934	346	51	-	-	-	-	-	-	-	-	-
	72	863	716	50	864	631	50	865	536	50	865	450	50	865	355	50	-	-	-	-	-	-
	67	803	803	49	796	724	49	798	630	49	798	543	49	798	447	49	799	359	50	-	-	-
	62	802	802	49	767	767	49	733	725	48	733	638	49	734	543	49	735	456	49	735	360	49
	57	802	802	49	766	766	49	731	731	48	696	696	48	674	640	48	676	547	48	676	453	48
21,000	77	946	657	51	947	555	51	949	453	51	949	359	51	-	-	-	-	-	-	-	-	-
	72	877	764	50	879	663	50	879	559	50	880	465	50	880	361	50	-	-	-	-	-	-
	67	832	832	49	810	770	49	814	669	49	814	567	50	814	469	50	814	366	50	-	-	-
	62	831	831	49	794	794	49	757	756	49	748	675	49	749	573	49	749	471	49	749	367	49
	57	830	830	49	794	794	49	756	756	49	720	720	48	687	673	48	689	572	48	689	469	48
24,000	77	965	705	51	967	590	51	969	484	51	970	368	51	-	-	-	-	-	-	-	-	-
	72	895	832	50	898	709	50	899	602	50	899	486	51	900	369	51	-	-	-	-	-	-
	67	869	869	50	830	830	50	832	716	50	832	607	50	832	491	50	832	374	50	-	-	-
	62	868	868	50	830	830	49	791	791	49	766	728	49	769	607	49	769	492	49	768	384	49
	57	867	867	50	829	829	50	790	790	49	751	751	49	713	713	48	706	614	48	707	495	49

**Table 89: 60 ton high capacity - 85°F ambient air temperature**

CFM	EWB (°F)	95°F EDB			90°F EDB			85°F EDB			80°F EDB			75°F EDB			70°F EDB			65°F EDB		
		TMBH	SMBH	kW	TMBH	SMBH	kW	TMBH	SMBH	kW	TMBH	SMBH	kW	TMBH	SMBH	kW	TMBH	SMBH	kW	TMBH	SMBH	kW
12,000	77	808	482	55	809	424	55	810	364	55	810	306	55	-	-	-	-	-	-	-	-	-
	72	744	542	54	744	481	54	745	428	54	746	367	54	746	306	54	-	-	-	-	-	-
	67	682	602	53	683	547	53	684	490	53	684	427	53	685	370	54	685	308	54	-	-	-
	62	644	644	53	626	606	52	626	545	53	627	488	53	627	429	53	627	371	53	627	312	53
	57	644	644	53	616	616	52	-	-	-	-	-	-	-	-	-	-	-	-	-	-	-
15,000	77	853	539	56	853	468	56	854	388	56	855	316	56	-	-	-	-	-	-	-	-	-
	72	787	614	55	788	541	55	788	471	55	789	398	55	789	324	55	-	-	-	-	-	-
	67	722	690	54	724	620	54	725	545	54	726	471	54	726	398	54	726	327	54	-	-	-
	62	708	708	54	677	677	53	665	621	53	666	551	53	667	473	53	668	403	53	668	327	53
	57	708	708	54	677	677	53	647	647	53	616	616	52	611	550	52	613	478	53	-	-	-
19,000	77	892	607	56	893	518	56	894	429	56	896	331	56	-	-	-	-	-	-	-	-	-
	72	826	710	55	828	613	55	828	522	56	829	431	56	829	340	56	-	-	-	-	-	-
	67	777	777	55	762	708	54	764	619	55	765	528	55	765	436	55	766	345	55	-	-	-
	62	776	776	55	741	741	54	707	707	54	703	626	54	704	528	54	704	437	54	704	345	54
	57	775	775	55	741	741	54	706	706	54	672	672	53	645	626	53	647	530	53	648	440	53
21,000	77	905	645	56	906	540	56	908	443	57	909	344	57	-	-	-	-	-	-	-	-	-
	72	839	748	56	841	649	56	841	550	56	842	445	56	842	345	56	-	-	-	-	-	-
	67	803	803	55	774	757	55	778	655	55	779	550	55	780	451	55	780	351	55	-	-	-
	62	803	803	55	767	767	55	731	731	54	715	659	54	718	556	54	718	457	54	717	352	54
	57	803	803	55	767	767	55	731	731	54	695	695	54	659	659	53	659	560	53	660	455	53
24,000	77	923	692	57	923	582	57	926	463	57	927	352	57	-	-	-	-	-	-	-	-	-
	72	855	812	56	859	696	56	860	584	56	861	473	56	861	362	56	-	-	-	-	-	-
	67	839	839	55	801	801	55	794	707	55	795	588	55	796	477	55	796	366	55	-	-	-
	62	838	838	55	800	800	55	763	763	55	731	709	54	735	596	54	735	478	55	735	367	55
	57	838	838	55	800	800	55	762	762	55	724	724	54	687	687	54	675	601	54	676	480	54

**Table 90: 60 ton high capacity - 95°F ambient air temperature**

CFM	EWB (°F)	95°F EDB			90°F EDB			85°F EDB			80°F EDB			75°F EDB			70°F EDB			65°F EDB		
		TMBH	SMBH	kW	TMBH	SMBH	kW	TMBH	SMBH	kW	TMBH	SMBH	kW	TMBH	SMBH	kW	TMBH	SMBH	kW	TMBH	SMBH	kW
12,000	77	774	469	61	774	406	61	775	350	61	775	287	61	-	-	-	-	-	-	-	-	-
	72	712	527	60	713	469	60	713	410	60	714	351	60	714	293	60	-	-	-	-	-	-
	67	653	590	59	654	530	59	655	470	59	655	416	59	656	356	59	656	295	59	-	-	-
	62	623	623	58	601	591	58	599	534	58	600	473	58	601	417	58	601	356	58	601	294	58
	57	623	623	58	596	596	58	-	-	-	-	-	-	-	-	-	-	-	-	-	-	-
15,000	77	814	523	62	815	450	62	815	378	62	816	302	62	-	-	-	-	-	-	-	-	-
	72	750	601	61	752	528	61	752	453	61	753	380	61	753	309	61	-	-	-	-	-	-
	67	692	675	59	690	604	60	692	530	60	693	456	60	694	385	60	694	312	60	-	-	-
	62	684	684	59	653	653	59	635	606	59	636	532	59	637	460	59	638	385	59	638	312	59
	57	684	684	59	653	653	59	623	623	58	594	594	58	584	537	58	584	461	58	585	386	58
19,000	77	849	594	62	850	502	62	852	409	62	853	324	62	-	-	-	-	-	-	-	-	-
	72	786	691	61	788	599	61	789	505	61	789	418	61	790	324	62	-	-	-	-	-	-
	67	748	748	60	724	695	60	727	604	60	729	510	60	730	423	61	730	328	61	-	-	-
	62	747	747	60	713	713	60	680	680	59	669	609	59	671	516	59	671	423	60	671	329	60
	57	747	747	60	713	713	60	679	679	59	646	646	59	615	609	58	616	517	59	617	426	59
21,000	77	861	630	62	863	530	62	864	428	63	864	328	63	-	-	-	-	-	-	-	-	-
	72	797	734	61	800	633	61	799	531	61	802	431	62	802	329	62	-	-	-	-	-	-
	67	773	773	61	740	734	60	739	637	60	742	537	61	742	436	61	743	334	61	-	-	-
	62	772	772	61	737	737	60	702	702	60	681	641	60	683	543	60	684	442	60	683	340	60
	57	772	772	61	737	737	60	702	702	60	667	667	59	633	633	59	627	546	59	628	440	59
24,000	77	-	-	-	-	-	-	880	449	63	882	335	63	-	-	-	-	-	-	-	-	-
	72	810	802	61	816	685	62	817	572	62	818	458	62	819	344	62	-	-	-	-	-	-
	67	806	806	61	769	769	61	755	695	61	757	576	61	757	462	61	757	348	61	-	-	-
	62	806	806	61	769	769	61	732	732	60	695	695	60	699	580	60	699	462	60	699	350	60
	57	805	805	61	767	767	61	732	732	60	695	695	60	659	659	59	641	584	59	643	463	59

**Table 91: 60 ton high capacity - 105°F ambient air temperature**

CFM	EWB (°F)	95°F EDB			90°F EDB			85°F EDB			80°F EDB			75°F EDB			70°F EDB			65°F EDB		
		TMBH	SMBH	kW	TMBH	SMBH	kW	TMBH	SMBH	kW	TMBH	SMBH	kW	TMBH	SMBH	kW	TMBH	SMBH	kW	TMBH	SMBH	kW
12,000	77	735	453	67	736	393	67	737	333	67	737	273	67	-	-	-	-	-	-	-	-	-
	72	677	515	66	678	453	66	679	397	66	680	341	66	680	279	66	-	-	-	-	-	-
	67	621	579	65	622	518	65	623	460	65	624	397	65	625	339	65	625	281	65	-	-	-
	62	600	600	64	573	573	64	571	521	64	571	462	64	572	398	64	572	340	64	573	281	64
	57	600	600	64	573	573	64	547	547	63	-	-	-	-	-	-	-	-	-	-	-	-
15,000	77	771	506	68	772	434	68	773	362	68	774	286	68	-	-	-	-	-	-	-	-	-
	72	711	586	67	714	511	67	714	437	67	715	368	67	716	293	67	-	-	-	-	-	-
	67	660	652	66	655	593	66	657	517	66	657	442	66	659	368	66	659	297	66	-	-	-
	62	657	657	66	627	627	65	604	590	65	604	519	65	605	443	65	606	372	65	606	297	65
	57	657	657	66	628	628	65	599	599	64	570	570	64	554	521	64	555	444	64	556	372	64
19,000	77	803	578	68	804	482	69	805	395	69	807	307	69	-	-	-	-	-	-	-	-	-
	72	741	674	67	745	581	67	747	493	68	747	404	68	748	307	68	-	-	-	-	-	-
	67	716	716	67	685	678	66	688	591	66	690	497	67	691	401	67	691	311	67	-	-	-
	62	715	715	67	683	683	66	651	651	66	633	595	65	635	502	65	636	407	66	636	311	66
	57	715	715	67	683	683	66	650	650	66	618	618	65	586	586	64	583	501	64	584	409	65
21,000	77	813	610	69	814	508	69	816	413	69	818	311	69	-	-	-	-	-	-	-	-	-
	72	752	720	67	755	613	68	757	518	68	758	416	68	759	317	68	-	-	-	-	-	-
	67	739	739	67	706	704	67	699	623	67	702	522	67	703	419	67	703	322	67	-	-	-
	62	739	739	67	705	705	67	672	672	66	643	630	66	646	526	66	647	424	66	647	322	66
	57	739	739	67	705	705	67	671	671	66	638	638	65	605	605	65	593	527	65	594	422	65
24,000	77	-	-	-	-	-	-	-	-	-	-	-	-	-	-	-	-	-	-	-	-	-
	72	770	770	68	769	669	68	771	555	68	773	440	68	774	325	68	-	-	-	-	-	-
	67	770	770	68	735	735	67	711	675	67	715	558	67	715	443	67	715	329	67	-	-	-
	62	769	769	68	734	734	67	699	699	67	664	664	66	662	563	66	661	450	66	661	330	66
	57	769	769	68	734	734	67	699	699	67	664	664	66	629	629	65	605	569	65	608	450	65

**Table 92: 60 ton high capacity - 115°F ambient air temperature**

CFM	EWB (°F)	95°F EDB			90°F EDB			85°F EDB			80°F EDB			75°F EDB			70°F EDB			65°F EDB		
		TMBH	SMBH	kW	TMBH	SMBH	kW	TMBH	SMBH	kW	TMBH	SMBH	kW	TMBH	SMBH	kW	TMBH	SMBH	kW	TMBH	SMBH	kW
12,000	77	694	436	74	694	378	74	695	321	74	697	258	74	-	-	-	-	-	-	-	-	-
	72	639	500	73	640	441	73	642	382	73	642	323	73	642	263	73	-	-	-	-	-	-
	67	587	560	71	588	501	72	589	442	72	590	381	72	591	326	72	591	266	72	-	-	-
	62	574	574	71	549	549	71	539	504	70	540	443	70	542	388	71	542	326	71	542	266	71
	57	574	574	71	549	549	71	524	524	70	499	499	69	495	445	69	496	387	69	496	327	70
15,000	77	725	490	75	727	416	75	728	345	75	729	273	75	-	-	-	-	-	-	-	-	-
	72	669	571	73	671	497	73	672	425	74	674	349	74	674	276	74	-	-	-	-	-	-
	67	628	628	72	617	572	72	619	501	72	620	425	72	621	353	73	621	280	73	-	-	-
	62	627	627	72	599	599	72	572	569	71	569	503	71	570	429	71	573	354	72	572	280	72
	57	627	627	72	599	599	72	571	571	71	543	543	71	522	506	70	523	429	70	524	356	70
19,000	77	752	557	75	754	468	75	756	378	76	758	288	76	-	-	-	-	-	-	-	-	-
	72	695	660	74	698	565	74	701	477	74	702	386	74	703	295	75	-	-	-	-	-	-
	67	682	682	74	651	651	73	648	576	73	648	480	73	649	383	73	650	292	73	-	-	-
	62	681	681	74	650	650	73	619	619	72	594	576	72	597	483	72	598	388	72	598	299	72
	57	680	680	74	650	650	73	618	618	72	588	588	72	557	557	71	548	488	71	549	390	71
21,000	77	-	-	-	-	-	-	-	-	-	-	-	-	-	-	-	-	-	-	-	-	-
	72	705	698	74	707	601	74	711	500	75	712	397	75	713	299	75	-	-	-	-	-	-
	67	702	702	74	671	671	73	654	608	73	657	508	73	659	400	74	660	302	74	-	-	-
	62	702	702	74	670	670	73	638	638	73	607	604	72	606	510	72	608	405	72	608	304	73
	57	702	702	74	670	670	73	638	638	73	606	606	72	574	574	71	556	512	71	558	408	71
24,000	77	-	-	-	-	-	-	-	-	-	-	-	-	-	-	-	-	-	-	-	-	-
	72	731	731	75	717	653	75	723	535	75	724	420	75	726	312	75	-	-	-	-	-	-
	67	730	730	75	697	697	74	665	659	73	669	542	74	671	423	74	671	309	74	-	-	-
	62	730	730	75	696	696	74	663	663	73	630	630	73	617	550	73	621	428	73	621	317	73
	57	729	729	75	696	696	74	663	663	73	629	629	73	596	596	72	567	550	71	570	433	72

**Table 93: 60 ton high capacity - 125°F ambient air temperature**

CFM	EWB (°F)	95°F EDB			90°F EDB			85°F EDB			80°F EDB			75°F EDB			70°F EDB			65°F EDB		
		TMBH	SMBH	kW	TMBH	SMBH	kW	TMBH	SMBH	kW	TMBH	SMBH	kW	TMBH	SMBH	kW	TMBH	SMBH	kW	TMBH	SMBH	kW
12,000	77	648	422	81	650	361	81	651	302	81	652	241	81	-	-	-	-	-	-	-	-	-
	72	598	486	80	599	425	80	601	364	80	602	303	80	602	247	80	-	-	-	-	-	-
	67	552	543	79	550	487	79	552	426	79	553	368	79	556	308	79	554	249	79	-	-	-
	62	547	547	78	522	522	78	506	486	77	506	431	78	508	370	78	508	311	78	509	249	78
	57	547	547	78	522	522	78	498	498	77	474	474	77	464	432	76	465	372	77	472	312	77
15,000	77	675	476	82	678	401	82	680	327	82	682	259	82	-	-	-	-	-	-	-	-	-
	72	623	553	80	625	481	81	628	406	81	629	332	81	630	258	81	-	-	-	-	-	-
	67	595	595	80	576	555	79	577	485	79	579	409	80	580	335	80	581	262	80	-	-	-
	62	594	594	80	568	568	79	541	541	78	531	486	78	533	413	78	534	335	79	535	262	79
	57	594	594	80	568	568	79	541	541	78	515	515	78	488	488	77	489	416	77	490	338	77
19,000	77	-	-	-	-	-	-	-	-	-	-	-	-	-	-	-	-	-	-	-	-	-
	72	645	645	81	648	551	81	652	456	81	654	366	82	655	275	82	-	-	-	-	-	-
	67	644	644	81	615	615	80	600	558	80	603	464	80	605	369	80	606	279	81	-	-	-
	62	643	643	81	614	614	80	585	585	80	555	555	79	555	466	79	557	373	79	558	279	79
	57	643	643	81	614	614	80	584	584	80	555	555	79	526	526	78	510	469	78	512	373	78
21,000	77	-	-	-	-	-	-	-	-	-	-	-	-	-	-	-	-	-	-	-	-	-
	72	663	663	81	655	583	81	661	484	82	662	382	82	663	279	82	-	-	-	-	-	-
	67	663	663	81	632	632	81	607	589	80	611	490	80	614	384	81	614	283	81	-	-	-
	62	662	662	81	634	634	81	602	602	80	575	575	79	563	491	79	566	388	80	566	288	80
	57	662	662	81	632	632	81	601	601	80	571	571	79	541	541	79	518	492	78	519	389	78
24,000	77	-	-	-	-	-	-	-	-	-	-	-	-	-	-	-	-	-	-	-	-	-
	72	-	-	-	662	635	81	669	522	82	672	403	82	-	-	-	-	-	-	-	-	-
	67	-	-	-	656	656	81	624	624	81	620	527	81	625	406	81	624	293	81	-	-	-
	62	-	-	-	655	655	81	624	624	81	592	592	80	573	533	80	574	413	80	576	294	80
	57	-	-	-	655	655	81	623	623	81	592	592	80	560	560	79	529	529	78	530	413	79

**Notes:**

Rated performance is at sea level. Cooling capacities are gross cooling capacities.  
 CFM = airflow, EWB = entering wet bulb air, EDB = entering dry bulb air, TMBH = total cooling capacity (MBH)  
 SMBH = sensible cooling capacity (MBH), kW = total input

## Cooling performance data 70 ton standard efficiency

**Table 94: 70 ton standard efficiency - 75°F ambient air temperature**

CFM	EWB (°F)	95°F EDB			90°F EDB			85°F EDB			80°F EDB			75°F EDB			70°F EDB			65°F EDB		
		TMBH	SMBH	kW	TMBH	SMBH	kW	TMBH	SMBH	kW	TMBH	SMBH	kW	TMBH	SMBH	kW	TMBH	SMBH	kW	TMBH	SMBH	kW
14,000	77	982	579	51	982	511	51	983	442	51	983	374	51	-	-	-	-	-	-	-	-	-
	72	901	649	51	902	586	51	902	514	51	902	442	51	901	370	51	-	-	-	-	-	-
	67	826	727	51	826	653	51	826	586	51	826	512	51	825	446	51	825	371	51	-	-	-
	62	773	773	51	752	722	51	754	656	51	754	581	51	754	513	51	753	445	51	754	369	51
	57	772	772	51	738	738	50	-	-	-	-	-	-	-	-	-	-	-	-	-	-	-
18,500	77	1051	662	51	1051	578	51	1051	484	51	1052	389	51	-	-	-	-	-	-	-	-	-
	72	968	765	51	968	668	51	968	581	51	968	484	51	968	397	51	-	-	-	-	-	-
	67	887	852	51	888	764	51	888	675	51	889	578	51	888	489	51	888	400	51	-	-	-
	62	873	873	51	833	833	51	813	764	51	815	676	51	815	587	51	814	489	51	814	399	51
	57	872	872	51	832	832	51	793	793	51	753	753	51	745	678	51	745	581	51	745	491	51
23,000	77	1094	744	51	1095	635	51	1096	526	51	1097	406	52	-	-	-	-	-	-	-	-	-
	72	1011	860	51	1011	748	51	1012	637	51	1011	526	52	1011	415	52	-	-	-	-	-	-
	67	950	950	51	931	866	51	931	754	51	932	643	51	932	531	51	931	419	52	-	-	-
	62	949	949	51	904	904	51	861	861	51	855	761	51	854	649	51	854	529	51	853	418	51
	57	948	948	51	904	904	51	860	860	51	817	817	51	781	758	51	783	650	51	782	532	51
27,500	77	1125	821	51	1126	687	51	1126	563	52	1127	428	52	-	-	-	-	-	-	-	-	-
	72	1041	957	51	1042	833	51	1042	698	52	1042	563	52	1042	427	52	-	-	-	-	-	-
	67	1009	1009	51	962	962	51	962	837	51	961	701	51	960	567	52	960	432	52	-	-	-
	62	1009	1009	51	962	962	51	914	914	51	883	839	51	884	707	51	884	574	51	883	441	52
	57	1008	1008	51	961	961	51	914	914	51	866	866	51	820	820	51	810	704	51	809	574	51
32,000	77	-	-	-	-	-	-	-	-	-	1149	437	52	-	-	-	-	-	-	-	-	-
	72	1059	1059	51	1064	904	52	1064	755	52	1065	596	52	1064	447	52	-	-	-	-	-	-
	67	1058	1058	51	1009	1009	51	983	914	51	983	757	52	983	600	52	982	452	52	-	-	-
	62	1057	1057	51	1007	1007	51	957	957	51	907	907	51	906	761	51	905	606	52	903	452	52
	57	1057	1057	51	1007	1007	51	957	957	51	907	907	51	858	858	51	830	764	51	830	606	51

**Table 95: 70 ton standard efficiency - 85°F ambient air temperature**

CFM	EWB (°F)	95°F EDB			90°F EDB			85°F EDB			80°F EDB			75°F EDB			70°F EDB			65°F EDB		
		TMBH	SMBH	kW	TMBH	SMBH	kW	TMBH	SMBH	kW	TMBH	SMBH	kW	TMBH	SMBH	kW	TMBH	SMBH	kW	TMBH	SMBH	kW
14,000	77	947	568	57	948	493	57	948	427	57	948	351	57	-	-	-	-	-	-	-	-	-
	72	834	625	63	834	550	63	835	484	63	835	409	63	834	342	63	-	-	-	-	-	-
	67	761	693	62	764	626	62	764	558	62	764	481	62	763	412	62	763	344	62	-	-	-
	62	728	728	62	695	695	62	695	626	62	697	550	62	697	481	62	696	411	62	696	341	62
	57	727	727	62	694	694	61	661	661	61	633	620	61	634	552	61	635	482	61	634	412	61
18,500	77	1012	647	58	1012	556	58	1012	465	58	1012	375	58	-	-	-	-	-	-	-	-	-
	72	931	745	57	931	652	57	931	568	57	931	475	57	932	382	57	-	-	-	-	-	-
	67	852	843	57	854	752	57	855	658	57	855	564	57	854	478	57	854	384	57	-	-	-
	62	847	847	57	808	808	56	780	749	56	783	658	56	783	564	57	783	477	57	782	383	57
	57	846	846	57	807	807	56	768	768	56	730	730	56	714	657	56	716	566	56	715	472	56
23,000	77	1052	736	58	1053	621	58	1053	505	58	1053	400	58	-	-	-	-	-	-	-	-	-
	72	971	845	57	971	738	57	971	621	58	971	515	58	971	398	58	-	-	-	-	-	-
	67	921	921	57	892	857	57	895	743	57	895	626	57	894	519	57	894	402	57	-	-	-
	62	920	920	57	876	876	57	833	833	57	819	737	57	819	631	57	819	516	57	818	401	57
	57	919	919	57	875	875	57	832	832	57	790	790	56	748	748	56	750	630	56	750	518	56
27,500	77	1080	810	58	1081	681	58	1082	541	58	1081	411	58	-	-	-	-	-	-	-	-	-
	72	997	947	58	999	809	58	1000	680	58	1000	550	58	1000	420	58	-	-	-	-	-	-
	67	978	978	57	931	931	57	922	821	57	921	682	57	921	552	57	920	423	58	-	-	-
	62	977	977	57	930	930	57	884	884	57	845	828	57	847	686	57	847	559	57	845	423	57
	57	977	977	57	930	930	57	883	883	57	837	837	57	792	792	57	775	690	57	774	557	57
32,000	77	-	-	-	-	-	-	-	-	-	-	-	-	-	-	-	-	-	-	-	-	-
	72	1025	1025	58	1019	887	58	1021	735	58	1020	582	58	1020	428	58	-	-	-	-	-	-
	67	1024	1024	58	975	975	57	940	893	57	942	744	58	942	584	58	940	432	58	-	-	-
	62	1024	1024	58	974	974	57	925	925	57	876	876	57	868	746	57	866	589	57	865	441	57
	57	1023	1023	58	974	974	57	924	924	57	875	875	57	827	827	57	793	745	57	794	588	57

**Table 96: 70 ton standard efficiency - 95°F ambient air temperature**

CFM	EWB (°F)	95°F EDB			90°F EDB			85°F EDB			80°F EDB			75°F EDB			70°F EDB			65°F EDB		
		TMBH	SMBH	kW	TMBH	SMBH	kW	TMBH	SMBH	kW	TMBH	SMBH	kW	TMBH	SMBH	kW	TMBH	SMBH	kW	TMBH	SMBH	kW
14,000	77	909	545	63	909	482	64	909	409	64	910	337	64	-	-	-	-	-	-	-	-	-
	72	675	513	54	676	451	54	677	395	54	678	335	54	678	278	54	-	-	-	-	-	-
	67	619	577	53	620	516	53	621	458	53	622	396	53	622	337	53	622	280	53	-	-	-
	62	597	597	53	571	571	53	568	518	53	568	460	53	569	401	53	569	338	53	569	279	53
	57	597	597	53	570	570	52	544	544	52	-	-	-	-	-	-	-	-	-	-	-	-
18,500	77	968	639	64	968	542	64	968	455	64	968	358	64	-	-	-	-	-	-	-	-	-
	72	891	730	63	891	642	63	891	544	64	891	454	64	891	365	64	-	-	-	-	-	-
	67	820	820	63	817	735	63	817	637	63	817	547	63	817	458	63	817	368	63	-	-	-
	62	819	819	63	780	780	62	745	738	62	748	643	62	749	554	62	749	457	62	748	367	62
	57	818	818	63	780	780	62	742	742	62	704	704	62	681	647	62	684	547	62	684	458	62
23,000	77	1005	713	64	1005	603	64	1005	493	64	1005	382	64	-	-	-	-	-	-	-	-	-
	72	927	835	64	927	723	64	927	603	64	927	492	64	927	380	64	-	-	-	-	-	-
	67	888	888	63	850	842	63	854	726	63	854	615	63	854	495	63	853	384	64	-	-	-
	62	887	887	63	845	845	63	803	803	63	781	726	63	782	610	63	781	500	63	781	382	63
	57	887	887	63	845	845	63	802	802	63	760	760	62	719	719	62	715	608	62	715	501	62
27,500	77	-	-	-	-	-	-	-	-	-	-	-	-	-	-	-	-	-	-	-	-	-
	72	949	930	64	953	801	64	954	668	64	953	534	64	954	401	64	-	-	-	-	-	-
	67	942	942	64	896	896	63	878	799	63	879	668	64	878	536	64	877	403	64	-	-	-
	62	941	941	64	896	896	63	850	850	63	806	806	63	807	670	63	807	540	63	805	402	63
	57	941	941	64	895	895	63	850	850	63	805	805	63	760	760	62	738	671	62	737	538	62
32,000	77	-	-	-	-	-	-	-	-	-	-	-	-	-	-	-	-	-	-	-	-	-
	72	986	986	64	971	874	64	972	719	64	972	564	64	971	418	65	-	-	-	-	-	-
	67	986	986	64	937	937	64	894	876	64	897	727	64	897	574	64	895	421	64	-	-	-
	62	985	985	64	936	936	64	889	889	63	841	841	63	825	726	63	824	569	63	822	419	63
	57	985	985	64	936	936	64	888	888	63	841	841	63	794	794	63	754	731	62	755	574	63

**Table 97: 70 ton standard efficiency - 105°F ambient air temperature**

CFM	EWB (°F)	95°F EDB			90°F EDB			85°F EDB			80°F EDB			75°F EDB			70°F EDB			65°F EDB		
		TMBH	SMBH	kW	TMBH	SMBH	kW	TMBH	SMBH	kW	TMBH	SMBH	kW	TMBH	SMBH	kW	TMBH	SMBH	kW	TMBH	SMBH	kW
14,000	77	867	537	70	867	460	70	867	390	70	868	321	70	-	-	-	-	-	-	-	-	-
	72	795	604	69	796	533	69	796	469	69	796	398	70	796	326	70	-	-	-	-	-	-
	67	724	681	68	727	611	69	728	539	69	728	466	69	728	393	69	728	328	69	-	-	-
	62	702	702	68	670	670	68	662	609	68	664	538	68	665	465	68	664	399	68	664	325	68
	57	702	702	68	669	669	68	637	637	67	605	605	67	604	537	67	605	466	67	605	393	67
18,500	77	920	617	71	921	525	71	921	433	71	921	341	71	-	-	-	-	-	-	-	-	-
	72	847	711	70	848	619	70	848	534	70	847	441	70	847	347	70	-	-	-	-	-	-
	67	789	789	69	775	721	69	777	622	69	777	528	69	777	443	69	777	349	69	-	-	-
	62	788	788	69	750	750	69	713	713	68	710	625	68	711	533	69	711	441	69	711	348	69
	57	788	788	69	750	750	69	713	713	68	676	676	68	647	628	68	650	533	68	650	442	68
23,000	77	953	696	71	954	582	71	954	477	71	955	363	71	-	-	-	-	-	-	-	-	-
	72	880	818	70	881	705	70	880	590	70	880	475	71	879	361	71	-	-	-	-	-	-
	67	853	853	70	812	812	70	810	704	70	810	592	70	810	478	70	809	364	70	-	-	-
	62	853	853	70	811	811	70	770	770	69	740	710	69	742	594	69	741	482	69	740	370	69
	57	852	852	70	811	811	70	770	770	69	728	728	69	689	689	68	677	596	68	678	481	68
27,500	77	-	-	-	-	-	-	-	-	-	-	-	-	-	-	-	-	-	-	-	-	-
	72	904	904	70	903	776	71	904	642	71	903	515	71	903	379	71	-	-	-	-	-	-
	67	903	903	70	859	859	70	830	789	70	832	649	70	831	515	70	830	382	70	-	-	-
	62	902	902	70	858	858	70	814	814	70	771	771	69	764	649	69	764	519	69	762	381	70
	57	902	902	70	857	857	70	814	814	70	770	770	69	727	727	69	697	655	68	698	517	69
32,000	77	-	-	-	-	-	-	-	-	-	-	-	-	-	-	-	-	-	-	-	-	-
	72	944	944	71	918	853	71	921	700	71	921	543	71	920	396	71	-	-	-	-	-	-
	67	943	943	71	897	897	70	850	850	70	849	705	70	848	551	70	847	398	71	-	-	-
	62	943	943	71	892	892	70	850	850	70	804	804	70	778	708	69	780	554	70	778	397	70
	57	943	943	71	896	896	70	850	850	70	803	803	70	758	758	69	712	712	69	715	550	69

**Table 98: 70 ton standard efficiency - 115°F ambient air temperature**

CFM	EWB (°F)	95°F EDB			90°F EDB			85°F EDB			80°F EDB			75°F EDB			70°F EDB			65°F EDB		
		TMBH	SMBH	kW	TMBH	SMBH	kW	TMBH	SMBH	kW	TMBH	SMBH	kW	TMBH	SMBH	kW	TMBH	SMBH	kW	TMBH	SMBH	kW
14,000	77	821	517	77	821	444	77	822	378	77	822	304	77	-	-	-	-	-	-	-	-	-
	72	753	587	76	754	520	76	754	445	76	754	377	77	753	309	77	-	-	-	-	-	-
	67	686	665	75	688	591	75	689	517	76	690	449	76	690	380	76	690	311	76	-	-	-
	62	674	674	75	642	642	75	627	595	75	628	521	75	630	447	75	630	378	75	629	308	75
	57	674	674	75	642	642	75	611	611	74	580	580	74	571	520	74	572	446	74	573	378	74
18,500	77	869	600	78	869	513	78	870	417	78	870	330	78	-	-	-	-	-	-	-	-	-
	72	799	695	77	800	600	77	800	512	77	800	424	77	800	328	77	-	-	-	-	-	-
	67	755	755	76	730	701	76	733	601	76	733	513	76	733	418	76	733	330	76	-	-	-
	62	754	754	76	718	718	76	682	682	75	669	609	75	671	517	75	671	423	75	671	329	76
	57	754	754	76	717	717	76	681	681	75	645	645	75	610	610	74	612	514	74	613	423	75
23,000	77	-	-	-	-	-	-	-	-	-	-	-	-	-	-	-	-	-	-	-	-	-
	72	826	801	77	830	680	78	830	573	78	829	456	78	828	348	78	-	-	-	-	-	-
	67	815	815	77	775	775	77	761	692	77	763	573	77	763	458	77	762	351	77	-	-	-
	62	814	814	77	774	774	77	734	734	76	696	689	76	699	573	76	698	461	76	697	348	76
	57	814	814	77	774	774	77	734	734	76	694	694	76	655	655	75	636	579	75	638	459	75
27,500	77	-	-	-	-	-	-	-	-	-	-	-	-	-	-	-	-	-	-	-	-	-
	72	862	862	78	848	763	78	850	629	78	850	493	78	850	365	78	-	-	-	-	-	-
	67	861	861	78	819	819	77	779	772	77	783	627	77	782	493	77	781	367	77	-	-	-
	62	861	861	78	818	818	77	775	775	77	733	733	76	717	631	76	719	496	76	717	366	77
	57	860	860	78	817	817	77	775	775	77	732	732	76	691	691	76	655	635	75	657	499	75
32,000	77	-	-	-	-	-	-	-	-	-	-	-	-	-	-	-	-	-	-	-	-	-
	72	-	-	-	859	842	78	864	683	78	865	528	78	865	372	79	-	-	-	-	-	-
	67	-	-	-	853	853	78	809	809	77	797	686	77	798	527	77	796	374	78	-	-	-
	62	-	-	-	853	853	78	808	808	77	763	763	77	730	694	76	733	535	77	730	380	77
	57	-	-	-	852	852	78	808	808	77	763	763	77	719	719	76	676	676	76	671	530	76

**Table 99: 70 ton standard efficiency - 125°F ambient air temperature**

CFM	EWB (°F)	95°F EDB			90°F EDB			85°F EDB			80°F EDB			75°F EDB			70°F EDB			65°F EDB		
		TMBH	SMBH	kW	TMBH	SMBH	kW	TMBH	SMBH	kW	TMBH	SMBH	kW	TMBH	SMBH	kW	TMBH	SMBH	kW	TMBH	SMBH	kW
14,000	77	772	494	85	772	425	85	772	355	85	773	286	85	-	-	-	-	-	-	-	-	-
	72	707	573	84	708	503	84	709	432	84	708	361	84	709	291	84	-	-	-	-	-	-
	67	644	644	83	645	574	83	647	505	83	648	434	83	649	363	83	649	292	83	-	-	-
	62	643	643	83	613	613	82	589	577	82	589	507	82	591	431	82	592	361	82	592	290	82
	57	643	643	83	612	612	82	582	582	82	552	552	81	537	505	81	537	430	81	538	361	81
18,500	77	77	814	578	86	813	488	86	814	399	86	814	309	86	-	-	-	-	-	-	-	-
	72	72	745	678	85	749	584	85	750	495	85	750	397	85	749	307	85	-	-	-	-	-
	67	67	718	718	84	683	683	84	685	589	84	687	495	84	687	405	84	686	309	84	-	-
	62	62	717	717	84	682	682	84	647	647	83	626	588	83	628	496	83	628	402	83	628	308
	57	57	717	717	84	682	682	84	647	647	83	612	612	82	578	578	82	572	497	82	574	402
23,000	77	77	-	-	-	-	-	-	-	-	-	-	-	-	-	-	-	-	-	-	-	-
	72	72	773	773	85	773	665	85	776	551	85	775	434	85	774	325	86	-	-	-	-	-
	67	67	773	773	85	734	734	84	709	673	84	713	556	84	714	442	85	712	327	85	-	-
	62	62	772	772	85	733	733	84	695	695	84	657	657	83	651	560	83	652	444	83	651	325
	57	57	771	771	85	733	733	84	695	695	84	657	657	83	619	619	83	594	558	82	596	441
27,500	77	77	-	-	-	-	-	-	-	-	-	-	-	-	-	-	-	-	-	-	-	-
	72	72	815	815	86	788	741	85	792	602	86	793	476	86	792	341	86	-	-	-	-	-
	67	67	815	815	86	773	773	85	733	733	84	730	613	85	730	474	85	728	342	85	-	-
	62	62	814	814	86	773	773	85	732	732	84	692	692	84	667	620	84	670	476	84	668	341
	57	57	814	814	86	773	773	85	732	732	84	692	692	84	651	651	83	612	612	83	612	477
32,000	77	77	-	-	-	-	-	-	-	-	-	-	-	-	-	-	-	-	-	-	-	-
	72	72	-	-	-	806	806	86	804	659	86	806	508	86	805	354	86	-	-	-	-	-
	67	67	-	-	-	805	805	86	762	762	85	740	666	85	743	505	85	741	356	85	-	-
	62	62	-	-	-	805	805	86	762	762	85	720	720	84	679	672	84	683	512	84	680	360
	57	57	-	-	-	804	804	86	762	762	85	719	719	84	677	677	84	636	636	83	623	517

**Notes:**

Rated performance is at sea level. Cooling capacities are gross cooling capacities.  
 CFM = airflow, EWB = entering wet bulb air, EDB = entering dry bulb air, TMBH = total cooling capacity (MBH)  
 SMBH = sensible cooling capacity (MBH), kW = total input

## Cooling performance data 70 ton high efficiency

**Table 100: 70 ton high efficiency - 75°F ambient air temperature**

CFM	EWB (°F)	95°F EDB			90°F EDB			85°F EDB			80°F EDB			75°F EDB			70°F EDB			65°F EDB		
		TMBH	SMBH	kW	TMBH	SMBH	kW	TMBH	SMBH	kW	TMBH	SMBH	kW	TMBH	SMBH	kW	TMBH	SMBH	kW	TMBH	SMBH	kW
14,000	77	968	576	49	970	508	49	970	437	49	971	367	49	-	-	-	-	-	-	-	-	-
	72	889	648	49	889	583	49	890	510	49	890	438	49	891	365	49	-	-	-	-	-	-
	67	814	725	49	814	651	49	815	583	49	815	508	49	816	442	49	816	367	49	-	-	-
	62	767	767	48	745	721	48	745	654	49	745	579	49	745	509	49	745	441	49	745	371	49
	57	766	766	48	733	733	48	700	700	48	-	-	-	-	-	-	-	-	-	-	-	-
18,500	77	1036	663	49	1036	574	49	1039	481	49	1039	384	49	-	-	-	-	-	-	-	-	-
	72	953	760	49	956	670	49	957	578	49	957	485	49	958	393	49	-	-	-	-	-	-
	67	877	854	49	876	765	49	877	673	49	877	579	49	879	489	49	879	395	49	-	-	-
	62	866	866	49	827	827	49	803	766	49	804	673	49	805	580	49	805	489	49	805	394	49
	57	865	865	49	826	826	49	787	787	49	748	748	49	735	674	49	736	582	49	737	489	49
23,000	77	1077	743	49	1079	637	49	1081	519	49	1082	411	50	-	-	-	-	-	-	-	-	-
	72	997	865	49	999	755	49	1000	635	49	1000	523	49	1000	410	50	-	-	-	-	-	-
	67	942	942	49	918	870	49	920	761	49	922	641	49	922	529	49	922	415	50	-	-	-
	62	942	942	49	899	899	49	855	855	49	844	758	49	846	647	49	846	527	49	845	414	49
	57	941	941	49	898	898	49	855	855	49	812	812	49	775	762	49	774	646	49	774	529	49
27,500	77	-	-	-	-	-	-	-	-	-	-	-	-	-	-	-	-	-	-	-	-	-
	72	1024	966	49	1029	830	49	1030	700	49	1030	563	50	1031	429	50	-	-	-	-	-	-
	67	1001	1001	49	956	953	49	949	841	49	950	703	49	950	567	50	950	434	50	-	-	-
	62	1001	1001	49	955	955	49	908	908	49	872	843	49	875	709	49	875	572	49	874	434	50
	57	1000	1000	49	954	954	49	907	907	49	861	861	49	816	816	49	800	710	49	801	572	49
32,000	77	-	-	-	-	-	-	-	-	-	-	-	-	-	-	-	-	-	-	-	-	-
	72	1048	1048	49	1048	901	49	1050	756	49	1052	599	50	1052	442	50	-	-	-	-	-	-
	67	1048	1048	49	999	999	49	968	919	49	972	758	49	971	602	50	971	447	50	-	-	-
	62	1047	1047	49	999	999	49	950	950	49	901	901	49	895	761	49	895	608	49	893	447	50
	57	1046	1046	49	998	998	49	949	949	49	901	901	49	852	852	49	821	771	49	822	608	49

**Table 101: 70 ton high efficiency - 85°F ambient air temperature**

CFM	EWB (°F)	95°F EDB			90°F EDB			85°F EDB			80°F EDB			75°F EDB			70°F EDB			65°F EDB		
		TMBH	SMBH	kW	TMBH	SMBH	kW	TMBH	SMBH	kW	TMBH	SMBH	kW	TMBH	SMBH	kW	TMBH	SMBH	kW	TMBH	SMBH	kW
14,000	77	935	566	55	936	490	55	937	423	55	938	347	55	-	-	-	-	-	-	-	-	-
	72	858	634	55	858	564	55	859	493	55	859	423	55	860	353	55	-	-	-	-	-	-
	67	785	708	54	786	635	54	786	570	54	787	498	54	787	426	54	787	354	54	-	-	-
	62	746	746	54	719	707	54	717	639	54	718	565	54	718	498	54	718	425	54	718	352	54
	57	746	746	54	712	712	54	679	679	53	-	-	-	-	-	-	-	-	-	-	-	-
18,500	77	1012	647	58	1012	556	58	1012	465	58	1012	375	58	-	-	-	-	-	-	-	-	-
	72	931	745	57	931	652	57	931	568	57	931	475	57	932	382	57	-	-	-	-	-	-
	67	852	843	57	854	752	57	855	658	57	855	564	57	854	478	57	854	384	57	-	-	-
	62	847	847	57	808	808	56	780	749	56	783	658	56	783	564	57	783	477	57	782	383	57
	57	846	846	57	807	807	56	768	768	56	730	730	56	714	657	56	716	566	56	715	472	56
23,000	77	1052	736	58	1053	621	58	1053	505	58	1053	400	58	-	-	-	-	-	-	-	-	-
	72	971	845	57	971	738	57	971	621	58	971	515	58	971	398	58	-	-	-	-	-	-
	67	921	921	57	892	857	57	895	743	57	895	626	57	894	519	57	894	402	57	-	-	-
	62	920	920	57	876	876	57	833	833	57	819	737	57	819	631	57	819	516	57	818	401	57
	57	919	919	57	875	875	57	832	832	57	790	790	56	748	748	56	750	630	56	750	518	56
27,500	77	1080	810	58	1081	681	58	1082	541	58	1081	411	58	-	-	-	-	-	-	-	-	-
	72	997	947	58	999	809	58	1000	680	58	1000	550	58	1000	420	58	-	-	-	-	-	-
	67	978	978	57	931	931	57	922	821	57	921	682	57	921	552	57	920	423	58	-	-	-
	62	977	977	57	930	930	57	884	884	57	845	828	57	847	686	57	847	559	57	845	423	57
	57	977	977	57	930	930	57	883	883	57	837	837	57	792	792	57	775	690	57	774	557	57
32,000	77	-	-	-	-	-	-	-	-	-	-	-	-	-	-	-	-	-	-	-	-	-
	72	1025	1025	58	1019	887	58	1021	735	58	1020	582	58	1020	428	58	-	-	-	-	-	-
	67	1024	1024	58	975	975	57	940	893	57	942	744	58	942	584	58	940	432	58	-	-	-
	62	1024	1024	58	974	974	57	925	925	57	876	876	57	868	746	57	866	589	57	865	441	57
	57	1023	1023	58	974	974	57	924	924	57	875	875	57	827	827	57	793	745	57	794	588	57

**Table 102: 70 ton high efficiency - 95°F ambient air temperature**

CFM	EWB (°F)	95°F EDB			90°F EDB			85°F EDB			80°F EDB			75°F EDB			70°F EDB			65°F EDB		
		TMBH	SMBH	kW	TMBH	SMBH	kW	TMBH	SMBH	kW	TMBH	SMBH	kW	TMBH	SMBH	kW	TMBH	SMBH	kW	TMBH	SMBH	kW
14,000	77	898	545	61	899	480	61	900	406	61	900	333	61	-	-	-	-	-	-	-	-	-
	72	823	625	60	824	550	61	825	481	61	825	406	61	825	338	61	-	-	-	-	-	-
	67	753	694	60	754	625	60	754	556	60	755	479	60	755	409	60	755	340	60	-	-	-
	62	723	723	60	692	686	59	688	626	59	688	556	59	689	479	60	689	409	60	689	338	60
	57	723	723	60	690	690	59	657	657	59	629	618	59	627	551	59	627	480	59	628	409	59
18,500	77	956	631	61	957	539	61	958	447	62	959	355	62	-	-	-	-	-	-	-	-	-
	72	879	733	61	881	640	61	882	547	61	882	453	61	883	362	61	-	-	-	-	-	-
	67	817	812	60	806	734	60	807	643	61	808	550	61	809	456	61	809	364	61	-	-	-
	62	813	813	60	776	776	60	742	732	60	739	645	60	740	548	60	740	456	60	740	363	60
	57	813	813	60	775	775	60	737	737	60	699	699	60	675	644	59	676	552	60	676	455	60
23,000	77	-	-	-	-	-	-	-	-	-	-	-	-	-	-	-	-	-	-	-	-	-
	72	915	833	61	918	722	61	919	609	61	919	490	62	919	378	62	-	-	-	-	-	-
	67	883	883	61	845	838	61	844	724	61	845	613	61	846	493	61	845	382	61	-	-	-
	62	882	882	61	841	841	61	799	799	60	773	732	60	774	615	60	775	498	61	773	380	61
	57	882	882	61	840	840	61	798	798	60	756	756	60	715	715	60	707	613	60	708	498	60
27,500	77	-	-	-	-	-	-	-	-	-	-	-	-	-	-	-	-	-	-	-	-	-
	72	942	929	61	942	804	61	944	661	62	944	532	62	944	397	62	-	-	-	-	-	-
	67	937	937	61	891	891	61	867	810	61	870	670	61	870	534	61	869	400	62	-	-	-
	62	936	936	61	891	891	61	846	846	61	803	797	61	798	676	61	799	538	61	798	399	61
	57	935	935	61	890	890	61	846	846	61	801	801	61	756	756	60	729	676	60	730	536	60
32,000	77	-	-	-	-	-	-	-	-	-	-	-	-	-	-	-	-	-	-	-	-	-
	72	-	-	-	957	880	61	961	721	62	963	568	62	963	414	62	-	-	-	-	-	-
	67	-	-	-	932	932	61	886	877	61	888	728	61	888	568	61	887	417	62	-	-	-
	62	-	-	-	931	931	61	883	883	61	837	837	61	815	733	61	817	572	61	814	415	61
	57	-	-	-	930	930	61	883	883	61	836	836	61	790	790	60	746	739	60	748	576	60

**Table 103: 70 ton high efficiency - 105°F ambient air temperature**

CFM	EWB (°F)	95°F EDB			90°F EDB			85°F EDB			80°F EDB			75°F EDB			70°F EDB			65°F EDB		
		TMBH	SMBH	kW	TMBH	SMBH	kW	TMBH	SMBH	kW	TMBH	SMBH	kW	TMBH	SMBH	kW	TMBH	SMBH	kW	TMBH	SMBH	kW
14,000	77	857	529	67	858	459	68	859	389	68	859	318	68	-	-	-	-	-	-	-	-	-
	72	786	605	67	787	533	67	787	467	67	788	395	67	788	323	67	-	-	-	-	-	-
	67	718	677	66	719	611	66	720	538	66	720	465	66	720	397	66	720	324	66	-	-	-
	62	698	698	66	666	666	65	656	610	65	657	537	65	657	464	66	657	395	66	657	322	66
	57	698	698	66	665	665	65	633	633	65	602	602	65	598	537	65	598	465	65	598	391	65
18,500	77	909	618	68	911	528	68	911	437	68	913	344	68	-	-	-	-	-	-	-	-	-
	72	837	714	67	838	623	67	839	529	68	839	434	68	839	344	68	-	-	-	-	-	-
	67	784	784	67	766	721	67	768	625	67	769	531	67	769	441	67	769	346	67	-	-	-
	62	783	783	67	746	746	66	711	706	66	702	627	66	703	534	66	704	439	66	704	345	66
	57	783	783	67	745	745	66	708	708	66	672	672	66	641	625	65	642	533	66	642	439	66
23,000	77	-	-	-	-	-	-	-	-	-	-	-	-	-	-	-	-	-	-	-	-	-
	72	869	817	68	871	704	68	872	589	68	872	474	68	872	359	68	-	-	-	-	-	-
	67	849	849	67	807	807	67	801	711	67	802	591	67	803	476	67	802	362	68	-	-	-
	62	848	848	67	807	807	67	766	766	67	733	709	66	734	598	67	735	480	67	734	367	67
	57	847	847	67	806	806	67	766	766	67	725	725	66	685	685	66	670	595	66	671	479	66
27,500	77	-	-	-	-	-	-	-	-	-	-	-	-	-	-	-	-	-	-	-	-	-
	72	901	898	68	892	782	68	895	645	68	896	514	68	895	376	69	-	-	-	-	-	-
	67	899	899	68	855	855	67	822	792	67	824	651	68	824	514	68	823	379	68	-	-	-
	62	898	898	68	854	854	67	810	810	67	767	767	67	755	655	67	757	517	67	756	383	67
	57	898	898	68	854	854	67	810	810	67	766	766	67	723	723	66	690	661	66	691	518	66
32,000	77	-	-	-	-	-	-	-	-	-	-	-	-	-	-	-	-	-	-	-	-	-
	72	-	-	-	906	860	68	911	701	68	912	547	68	912	392	69	-	-	-	-	-	-
	67	-	-	-	892	892	68	846	846	67	838	713	68	840	546	68	840	395	68	-	-	-
	62	-	-	-	891	891	68	846	846	67	800	800	67	771	717	67	774	549	67	770	393	68
	57	-	-	-	891	891	68	846	846	67	799	799	67	754	754	67	709	709	66	707	558	67

**Table 104: 70 ton high efficiency - 115°F ambient air temperature**

CFM	EWB (°F)	95°F EDB			90°F EDB			85°F EDB			80°F EDB			75°F EDB			70°F EDB			65°F EDB		
		TMBH	SMBH	kW	TMBH	SMBH	kW	TMBH	SMBH	kW	TMBH	SMBH	kW	TMBH	SMBH	kW	TMBH	SMBH	kW	TMBH	SMBH	kW
14,000	77	812	517	74	812	443	74	814	376	75	814	301	75	-	-	-	-	-	-	-	-	-
	72	744	588	74	745	519	74	745	444	74	746	376	74	747	306	74	-	-	-	-	-	-
	67	681	659	73	681	592	73	681	517	73	682	448	73	683	378	73	683	307	73	-	-	-
	62	670	670	72	639	639	72	621	591	72	622	522	72	622	451	72	622	376	72	623	305	72
	57	669	669	72	638	638	72	607	607	72	576	576	71	566	521	71	567	446	71	567	376	71
18,500	77	-	-	-	-	-	-	-	-	-	-	-	-	-	-	-	-	-	-	-	-	-
	72	788	699	74	790	603	74	792	512	74	792	417	74	793	325	75	-	-	-	-	-	-
	67	750	750	73	724	700	73	724	609	73	725	515	74	726	424	74	726	327	74	-	-	-
	62	749	749	73	713	713	73	677	677	73	663	610	73	663	515	73	664	421	73	665	326	73
	57	749	749	73	713	713	73	677	677	73	641	641	72	609	603	72	605	517	72	606	420	72
23,000	77	-	-	-	-	-	-	-	-	-	-	-	-	-	-	-	-	-	-	-	-	-
	72	818	798	74	818	686	75	822	571	75	822	455	75	822	345	75	-	-	-	-	-	-
	67	810	810	74	771	771	74	753	691	74	755	577	74	756	456	74	756	348	74	-	-	-
	62	810	810	74	770	770	74	730	730	73	693	687	73	691	578	73	692	460	73	691	347	74
	57	809	809	74	769	769	74	730	730	73	691	691	73	652	652	73	630	579	72	631	463	73
27,500	77	-	-	-	-	-	-	-	-	-	-	-	-	-	-	-	-	-	-	-	-	-
	72	-	-	-	838	766	75	841	628	75	843	492	75	842	359	76	-	-	-	-	-	-
	67	-	-	-	814	814	74	775	765	74	774	632	74	776	497	75	775	361	75	-	-	-
	62	-	-	-	813	813	74	771	771	74	729	729	74	709	636	74	711	500	74	711	363	74
	57	-	-	-	812	812	74	771	771	74	729	729	74	687	687	73	649	641	73	649	500	73
32,000	77	-	-	-	-	-	-	-	-	-	-	-	-	-	-	-	-	-	-	-	-	-
	72	-	-	-	-	-	-	856	684	75	858	532	75	858	377	76	-	-	-	-	-	-
	67	-	-	-	-	-	-	804	804	74	788	693	74	790	530	75	789	379	75	-	-	-
	62	-	-	-	-	-	-	804	804	74	760	760	74	723	701	74	724	536	74	724	376	74
	57	-	-	-	848	848	75	804	804	74	759	759	74	716	716	74	672	672	73	663	537	73

**Table 105: 70 ton high efficiency - 125°F ambient air temperature**

CFM	EWB (°F)	95°F EDB			90°F EDB			85°F EDB			80°F EDB			75°F EDB			70°F EDB			65°F EDB		
		TMBH	SMBH	kW	TMBH	SMBH	kW	TMBH	SMBH	kW	TMBH	SMBH	kW	TMBH	SMBH	kW	TMBH	SMBH	kW	TMBH	SMBH	kW
14,000	77	631	410	68	632	347	68	632	291	68	633	234	68	-	-	-	-	-	-	-	-	-
	72	699	573	81	700	503	81	701	431	81	702	360	81	702	288	81	-	-	-	-	-	-
	67	643	637	80	640	572	80	641	500	80	641	433	80	642	362	80	642	289	80	-	-	-
	62	640	640	80	609	609	79	585	570	79	584	502	79	585	431	79	585	359	80	585	287	80
	57	639	639	80	608	608	79	578	578	79	548	548	79	531	500	78	532	430	78	532	358	79
18,500	77	-	-	-	-	-	-	-	-	-	-	-	-	-	-	-	-	-	-	-	-	-
	72	738	677	81	740	587	82	741	494	82	743	399	82	744	305	82	-	-	-	-	-	-
	67	714	714	81	682	674	81	678	590	81	680	494	81	680	404	81	681	306	81	-	-	-
	62	713	713	81	678	678	81	643	643	80	620	589	80	622	496	80	622	404	80	622	309	80
	57	712	712	81	678	678	81	643	643	80	609	609	80	575	573	79	566	500	79	567	403	79
23,000	77	-	-	-	-	-	-	-	-	-	-	-	-	-	-	-	-	-	-	-	-	-
	72	770	770	82	764	671	82	768	550	82	769	441	82	769	324	83	-	-	-	-	-	-
	67	769	769	82	731	731	81	703	674	81	705	556	81	706	440	82	706	326	82	-	-	-
	62	769	769	82	730	730	81	692	692	81	654	654	80	645	560	81	646	442	81	646	324	81
	57	768	768	82	729	729	81	692	692	81	654	654	80	616	616	80	588	558	80	590	444	80
27,500	77	-	-	-	-	-	-	-	-	-	-	-	-	-	-	-	-	-	-	-	-	-
	72	-	-	-	782	745	82	784	609	83	786	475	83	786	338	83	-	-	-	-	-	-
	67	-	-	-	770	770	82	730	730	82	721	618	82	724	478	82	723	340	82	-	-	-
	62	-	-	-	769	769	82	729	729	82	689	689	81	661	619	81	663	480	81	663	343	81
	57	-	-	-	769	769	82	729	729	82	688	688	81	649	649	80	610	608	80	605	482	80
32,000	77	-	-	-	-	-	-	-	-	-	-	-	-	-	-	-	-	-	-	-	-	-
	72	-	-	-	-	-	-	-	-	-	-	-	-	-	-	-	-	-	-	-	-	-
	67	-	-	-	-	-	-	760	760	82	733	675	82	737	514	82	736	353	83	-	-	-
	62	-	-	-	-	-	-	759	759	82	716	716	81	675	675	81	675	513	81	674	357	82
	57	-	-	-	-	-	-	759	759	82	716	716	81	674	674	81	633	633	80	616	518	80

**Notes:**  
 Rated performance is at sea level. Cooling capacities are gross cooling capacities.  
 CFM = airflow, EWB = entering wet bulb air, EDB = entering dry bulb air, TMBH = total cooling capacity (MBH)  
 SMBH = sensible cooling capacity (MBH), kW = total input

## Cooling performance data 70 ton high capacity

**Table 106: 70 ton high capacity - 75°F ambient air temperature**

CFM	EWB (°F)	95°F EDB			90°F EDB			85°F EDB			80°F EDB			75°F EDB			70°F EDB			65°F EDB		
		TMBH	SMBH	kW	TMBH	SMBH	kW	TMBH	SMBH	kW	TMBH	SMBH	kW	TMBH	SMBH	kW	TMBH	SMBH	kW	TMBH	SMBH	kW
14,000	77	1031	601	56	1032	530	56	1032	456	56	1032	391	56	-	-	-	-	-	-	-	-	-
	72	947	677	56	948	602	56	948	534	56	949	465	56	949	389	56	-	-	-	-	-	-
	67	865	752	55	867	674	55	868	603	55	869	533	55	869	462	55	870	391	55	-	-	-
	62	805	805	55	791	751	55	792	679	55	793	607	55	794	535	55	794	462	55	794	396	55
	57	805	805	55	770	770	54	-	-	-	-	-	-	-	-	-	-	-	-	-	-	-
18,500	77	1107	686	57	1108	602	57	1109	507	57	1110	411	57	-	-	-	-	-	-	-	-	-
	72	1021	783	56	1022	695	56	1022	607	56	1023	508	56	1023	420	56	-	-	-	-	-	-
	67	936	883	56	939	792	56	940	695	56	940	605	56	940	514	56	940	423	56	-	-	-
	62	911	911	55	872	869	55	860	794	55	861	704	55	863	607	55	862	515	55	862	423	56
	57	911	911	55	872	872	55	832	832	55	792	792	55	788	702	55	790	608	55	790	514	55
23,000	77	1157	770	57	1159	664	57	1160	547	57	1161	432	57	-	-	-	-	-	-	-	-	-
	72	1071	896	56	1072	779	57	1073	669	57	1073	551	57	1073	440	57	-	-	-	-	-	-
	67	995	995	56	986	904	56	988	786	56	989	668	56	989	556	56	989	445	56	-	-	-
	62	994	994	56	950	950	56	907	899	56	907	786	56	908	675	56	908	557	56	908	445	56
	57	994	994	56	949	949	56	905	905	55	860	860	55	831	789	55	833	675	55	834	558	55
27,500	77	1191	854	57	1193	720	57	1195	582	57	1196	455	57	-	-	-	-	-	-	-	-	-
	72	1104	997	57	1105	862	57	1107	723	57	1107	594	57	1109	455	57	-	-	-	-	-	-
	67	1059	1059	56	1018	1001	56	1024	867	56	1023	730	56	1023	597	57	1022	460	57	-	-	-
	62	1058	1058	56	1011	1011	56	963	963	56	939	871	56	941	734	56	941	599	56	941	467	56
	57	1058	1058	56	1011	1011	56	963	963	56	915	915	56	867	867	55	864	734	56	863	604	56
32,000	77	-	-	-	-	-	-	-	-	-	-	-	-	-	-	-	-	-	-	-	-	-
	72	1125	1091	57	1131	939	57	1132	781	57	1133	623	57	1134	476	57	-	-	-	-	-	-
	67	1112	1112	57	1062	1062	56	1046	942	57	1047	785	57	1048	629	57	1048	482	57	-	-	-
	62	1112	1112	57	1061	1061	56	1010	1010	56	962	953	56	967	793	56	967	638	56	966	483	57
	57	1111	1111	56	1060	1060	56	1010	1010	56	959	959	56	909	909	56	887	798	56	887	639	56

**Table 107: 70 ton high capacity - 85°F ambient air temperature**

CFM	EWB (°F)	95°F EDB			90°F EDB			85°F EDB			80°F EDB			75°F EDB			70°F EDB			65°F EDB		
		TMBH	SMBH	kW	TMBH	SMBH	kW	TMBH	SMBH	kW	TMBH	SMBH	kW	TMBH	SMBH	kW	TMBH	SMBH	kW	TMBH	SMBH	kW
14,000	77	996	583	62	996	512	63	997	449	63	998	377	63	-	-	-	-	-	-	-	-	-
	72	914	665	62	915	590	62	916	516	62	916	450	62	916	376	62	-	-	-	-	-	-
	67	835	735	61	836	666	61	837	591	61	838	523	61	839	446	61	839	378	61	-	-	-
	62	783	783	60	764	732	60	764	663	60	765	593	60	765	523	61	766	452	61	766	375	61
	57	783	783	60	749	749	60	-	-	-	-	-	-	-	-	-	-	-	-	-	-	-
18,500	77	1067	673	63	1068	581	63	1069	488	63	1068	395	63	-	-	-	-	-	-	-	-	-
	72	983	774	62	984	679	63	985	584	63	985	499	63	986	404	63	-	-	-	-	-	-
	67	900	874	62	902	779	62	904	684	62	904	591	62	905	495	62	905	407	62	-	-	-
	62	885	885	61	845	845	61	826	780	61	828	685	61	830	592	61	830	501	61	830	406	61
	57	885	885	61	844	844	61	806	806	61	767	767	60	758	690	61	759	592	61	760	502	61
23,000	77	1113	753	63	1115	641	64	1116	528	64	1117	415	64	-	-	-	-	-	-	-	-	-
	72	1029	873	63	1031	759	63	1031	653	63	1031	538	63	1032	423	63	-	-	-	-	-	-
	67	965	965	62	946	888	62	949	766	62	950	651	62	950	543	63	949	427	63	-	-	-
	62	964	964	62	920	920	62	876	876	62	870	772	62	872	658	62	872	542	62	871	427	62
	57	964	964	62	920	920	62	876	876	62	832	832	61	796	780	61	799	655	61	800	544	61
27,500	77	-	-	-	-	-	-	1149	574	64	1150	437	64	-	-	-	-	-	-	-	-	-
	72	1058	977	63	1061	846	63	1062	712	63	1063	578	63	1063	443	64	-	-	-	-	-	-
	67	1027	1027	63	982	976	62	980	849	63	981	716	63	981	582	63	981	441	63	-	-	-
	62	1026	1026	63	979	979	62	931	931	62	900	858	62	903	716	62	902	581	62	902	448	62
	57	1026	1026	63	978	978	62	931	931	62	885	885	62	837	837	61	827	719	61	827	579	62
32,000	77	-	-	-	-	-	-	-	-	-	-	-	-	-	-	-	-	-	-	-	-	-
	72	1078	1078	63	1085	922	63	1086	771	64	1087	609	64	1087	456	64	-	-	-	-	-	-
	67	1077	1077	63	1027	1027	63	1002	932	63	1004	773	63	1005	613	63	1004	462	63	-	-	-
	62	1077	1077	63	1027	1027	63	977	977	62	926	926	62	926	778	62	926	620	63	925	462	63
	57	1076	1076	63	1026	1026	63	976	976	62	926	926	62	876	876	62	848	780	62	849	620	62

**Table 108: 70 ton high capacity - 95°F ambient air temperature**

CFM	EWB (°F)	95°F EDB			90°F EDB			85°F EDB			80°F EDB			75°F EDB			70°F EDB			65°F EDB		
		TMBH	SMBH	kW	TMBH	SMBH	kW	TMBH	SMBH	kW	TMBH	SMBH	kW	TMBH	SMBH	kW	TMBH	SMBH	kW	TMBH	SMBH	kW
14,000	77	956	569	69	956	501	69	958	433	69	958	354	69	-	-	-	-	-	-	-	-	-
	72	877	646	68	879	576	68	879	504	68	880	433	69	879	361	69	-	-	-	-	-	-
	67	801	721	67	802	649	67	803	576	67	804	501	68	805	436	68	806	362	68	-	-	-
	62	759	759	67	734	716	67	733	651	67	733	577	67	734	503	67	735	435	67	735	360	67
	57	759	759	67	725	725	66	692	692	66	-	-	-	-	-	-	-	-	-	-	-	-
18,500	77	1022	655	70	1023	566	70	1024	478	70	1024	379	70	-	-	-	-	-	-	-	-	-
	72	941	756	69	942	660	69	943	569	69	943	478	69	943	387	69	-	-	-	-	-	-
	67	864	850	68	863	762	68	865	666	68	866	572	68	866	482	69	866	390	69	-	-	-
	62	856	856	68	817	817	68	790	761	67	791	670	67	793	574	68	794	482	68	794	389	68
	57	856	856	68	817	817	68	779	779	67	740	740	67	724	673	67	725	580	67	726	479	67
23,000	77	1065	745	70	1066	629	71	1067	512	71	1067	405	71	-	-	-	-	-	-	-	-	-
	72	982	863	70	985	745	70	985	634	70	986	516	70	986	404	70	-	-	-	-	-	-
	67	932	932	69	903	865	69	906	749	69	907	638	69	907	520	69	907	408	69	-	-	-
	62	931	931	69	888	888	68	845	845	68	830	754	68	832	637	68	832	526	68	832	409	68
	57	931	931	69	888	888	68	844	844	68	802	802	68	761	761	67	762	640	67	763	527	67
27,500	77	-	-	-	-	-	-	-	-	-	-	-	-	-	-	-	-	-	-	-	-	-
	72	1008	961	70	1012	827	70	1014	689	70	1014	555	70	1015	423	70	-	-	-	-	-	-
	67	990	990	69	944	944	69	933	834	69	936	693	69	936	559	70	936	427	70	-	-	-
	62	990	990	69	943	943	69	897	897	69	857	837	68	860	697	69	860	562	69	859	430	69
	57	989	989	69	943	943	69	897	897	69	851	851	68	805	805	68	787	708	68	788	559	68
32,000	77	-	-	-	-	-	-	-	-	-	-	-	-	-	-	-	-	-	-	-	-	-
	72	1039	1039	70	1033	898	70	1036	746	70	1036	591	71	1036	435	71	-	-	-	-	-	-
	67	1038	1038	70	989	989	70	954	916	69	957	756	70	957	593	70	957	440	70	-	-	-
	62	1037	1037	70	988	988	70	939	939	69	890	890	69	881	757	69	882	600	69	880	440	69
	57	1036	1036	70	988	988	70	938	938	69	890	890	69	841	841	68	806	766	68	808	598	68

**Table 109: 70 ton high capacity - 105°F ambient air temperature**

CFM	EWB (°F)	95°F EDB			90°F EDB			85°F EDB			80°F EDB			75°F EDB			70°F EDB			65°F EDB		
		TMBH	SMBH	kW	TMBH	SMBH	kW	TMBH	SMBH	kW	TMBH	SMBH	kW	TMBH	SMBH	kW	TMBH	SMBH	kW	TMBH	SMBH	kW
14,000	77	913	553	76	914	480	76	915	413	77	915	339	77	-	-	-	-	-	-	-	-	-
	72	837	626	75	838	557	75	839	489	75	840	413	76	840	344	76	-	-	-	-	-	-
	67	764	703	74	766	628	74	766	557	74	767	487	74	768	416	75	769	346	75	-	-	-
	62	732	732	74	701	696	73	699	629	73	700	559	73	700	487	73	701	415	74	701	344	74
	57	732	732	74	699	699	73	667	667	73	638	631	72	638	562	72	639	486	72	639	416	73
18,500	77	973	639	77	973	549	77	975	455	77	975	361	78	-	-	-	-	-	-	-	-	-
	72	894	736	76	896	643	76	897	550	76	897	461	76	898	368	77	-	-	-	-	-	-
	67	828	820	75	820	741	75	822	647	75	823	555	75	824	464	76	824	371	76	-	-	-
	62	824	824	75	786	786	75	753	741	74	752	652	74	755	559	74	755	463	75	754	370	75
	57	824	824	75	786	786	75	748	748	74	711	711	74	688	654	73	689	558	73	690	462	74
23,000	77	-	-	-	-	-	-	1014	497	78	1015	386	78	-	-	-	-	-	-	-	-	-
	72	930	847	77	935	727	77	936	613	77	936	499	77	936	385	77	-	-	-	-	-	-
	67	896	896	76	858	844	76	859	736	76	861	616	76	861	503	76	861	387	76	-	-	-
	62	894	894	76	852	852	76	810	810	75	787	738	75	789	619	75	789	507	75	789	388	75
	57	894	894	76	852	852	76	810	810	75	769	769	74	728	728	74	722	621	74	723	506	74
27,500	77	-	-	-	-	-	-	-	-	-	-	-	-	-	-	-	-	-	-	-	-	-
	72	956	943	77	959	809	77	961	673	77	962	535	78	962	404	78	-	-	-	-	-	-
	67	949	949	77	905	905	76	883	816	76	887	675	76	887	544	77	886	405	77	-	-	-
	62	949	949	77	904	904	76	859	859	76	816	811	75	814	681	75	815	541	76	814	407	76
	57	949	949	77	904	904	76	859	859	76	814	814	75	770	770	75	744	685	74	746	545	75
32,000	77	-	-	-	-	-	-	-	-	-	-	-	-	-	-	-	-	-	-	-	-	-
	72	995	995	77	975	887	77	981	726	78	981	569	78	981	422	78	-	-	-	-	-	-
	67	994	994	77	946	946	77	902	893	76	906	734	77	906	580	77	906	426	77	-	-	-
	62	993	993	77	946	946	77	900	900	76	851	851	76	830	739	76	834	576	76	833	425	76
	57	993	993	77	945	945	77	898	898	76	851	851	76	803	803	75	762	746	75	764	581	75

**Table 110: 70 ton high capacity - 115°F ambient air temperature**

CFM	EWB (°F)	95°F EDB			90°F EDB			85°F EDB			80°F EDB			75°F EDB			70°F EDB			65°F EDB		
		TMBH	SMBH	kW	TMBH	SMBH	kW	TMBH	SMBH	kW	TMBH	SMBH	kW	TMBH	SMBH	kW	TMBH	SMBH	kW	TMBH	SMBH	kW
14,000	77	865	534	84	867	464	84	869	392	84	868	321	84	-	-	-	-	-	-	-	-	-
	72	792	610	83	794	537	83	795	465	83	796	399	83	796	326	83	-	-	-	-	-	-
	67	725	683	82	725	610	82	726	543	82	727	469	82	728	402	82	728	328	82	-	-	-
	62	703	703	81	671	671	81	662	611	81	663	543	81	664	469	81	664	400	81	665	326	81
	57	703	703	81	671	671	81	639	639	80	608	608	80	605	539	80	606	472	80	606	400	80
18,500	77	919	622	85	920	528	85	921	436	85	922	341	85	-	-	-	-	-	-	-	-	-
	72	843	720	84	846	623	84	848	534	84	848	438	84	848	348	84	-	-	-	-	-	-
	67	790	790	83	774	720	83	775	631	83	777	536	83	778	441	83	778	350	83	-	-	-
	62	789	789	83	752	752	82	717	713	82	710	634	82	711	541	82	713	444	82	713	349	82
	57	789	789	83	752	752	82	716	716	82	679	679	81	649	636	81	650	540	81	652	443	81
23,000	77	-	-	-	-	-	-	-	-	-	-	-	-	-	-	-	-	-	-	-	-	-
	72	876	824	84	880	711	85	882	595	85	883	480	85	882	363	85	-	-	-	-	-	-
	67	856	856	84	814	814	83	809	719	83	811	598	84	812	482	84	812	367	84	-	-	-
	62	855	855	84	814	814	83	773	773	83	741	717	82	743	599	83	744	486	83	743	372	83
	57	855	855	84	814	814	83	773	773	83	733	733	82	692	692	81	679	604	81	681	483	82
27,500	77	-	-	-	-	-	-	-	-	-	-	-	-	-	-	-	-	-	-	-	-	-
	72	907	904	85	900	789	85	905	651	85	905	519	85	905	380	86	-	-	-	-	-	-
	67	905	905	85	862	862	84	830	799	84	833	659	84	835	521	84	834	384	85	-	-	-
	62	905	905	85	861	861	84	818	818	83	774	774	83	765	663	83	767	524	83	766	388	83
	57	905	905	85	861	861	84	818	818	83	774	774	83	731	731	82	699	664	82	701	526	82
32,000	77	-	-	-	-	-	-	-	-	-	-	-	-	-	-	-	-	-	-	-	-	-
	72	-	-	-	917	862	85	921	709	85	922	553	86	922	397	86	-	-	-	-	-	-
	67	-	-	-	901	901	85	855	855	84	850	714	84	851	553	85	851	400	85	-	-	-
	62	-	-	-	901	901	85	854	854	84	808	808	83	780	718	83	783	556	84	782	399	84
	57	-	-	-	900	900	85	854	854	84	808	808	83	762	762	83	718	718	82	717	566	82

**Table 111: 70 ton high capacity - 125°F ambient air temperature**

CFM	EWB (°F)	95°F EDB			90°F EDB			85°F EDB			80°F EDB			75°F EDB			70°F EDB			65°F EDB		
		TMBH	SMBH	kW	TMBH	SMBH	kW	TMBH	SMBH	kW	TMBH	SMBH	kW	TMBH	SMBH	kW	TMBH	SMBH	kW	TMBH	SMBH	kW
14,000	77	813	518	92	814	444	93	815	376	93	816	302	93	-	-	-	-	-	-	-	-	-
	72	744	588	91	746	521	91	747	451	91	748	377	92	749	307	92	-	-	-	-	-	-
	67	683	660	90	682	595	90	683	525	90	684	449	90	685	379	90	685	308	91	-	-	-
	62	672	672	90	640	640	89	623	592	89	623	523	89	624	452	89	625	377	89	625	306	89
	57	672	672	90	640	640	89	609	609	89	579	579	88	568	523	88	569	449	88	569	376	88
18,500	77	861	602	93	863	509	94	864	415	94	865	329	94	-	-	-	-	-	-	-	-	-
	72	789	700	92	791	607	92	794	513	92	795	419	93	795	326	93	-	-	-	-	-	-
	67	752	752	91	724	703	91	726	612	91	728	517	91	729	420	91	729	328	92	-	-	-
	62	751	751	91	715	715	91	679	679	90	664	611	90	665	517	90	667	422	90	668	327	91
	57	751	751	91	715	715	91	679	679	90	644	644	89	609	609	89	609	517	89	609	426	89
23,000	77	-	-	-	-	-	-	-	-	-	-	-	-	-	-	-	-	-	-	-	-	-
	72	819	799	93	821	688	93	823	572	93	825	456	93	825	347	94	-	-	-	-	-	-
	67	811	811	92	772	772	92	754	693	92	757	580	92	759	458	92	760	350	92	-	-	-
	62	811	811	92	772	772	92	732	732	91	694	694	90	693	580	91	695	461	91	694	348	91
	57	811	811	92	772	772	92	732	732	91	693	693	90	655	655	90	633	582	90	635	463	90
27,500	77	-	-	-	-	-	-	-	-	-	-	-	-	-	-	-	-	-	-	-	-	-
	72	-	-	-	837	771	93	844	630	94	845	493	94	845	361	94	-	-	-	-	-	-
	67	-	-	-	815	815	93	776	769	92	775	641	92	779	498	93	778	363	93	-	-	-
	62	857	857	93	815	815	93	773	773	92	731	731	91	712	643	91	714	500	91	714	364	92
	57	856	856	93	815	815	93	773	773	92	731	731	91	690	690	91	651	645	90	653	503	90
32,000	77	-	-	-	-	-	-	-	-	-	-	-	-	-	-	-	-	-	-	-	-	-
	72	-	-	-	853	845	93	858	686	94	860	533	94	860	378	94	-	-	-	-	-	-
	67	-	-	-	850	850	93	806	806	93	790	695	93	794	532	93	792	380	93	-	-	-
	62	-	-	-	850	850	93	806	806	93	762	762	92	725	704	91	727	538	92	728	379	92
	57	-	-	-	849	849	93	805	805	93	762	762	92	718	718	91	675	675	90	665	546	91

**Notes:**

Rated performance is at sea level. Cooling capacities are gross cooling capacities.  
 CFM = airflow, EWB = entering wet bulb air, EDB = entering dry bulb air, TMBH = total cooling capacity (MBH)  
 SMBH = sensible cooling capacity (MBH), kW = total input

## Cooling performance data 80 ton standard efficiency

**Table 112: 80 ton standard efficiency - 75°F ambient air temperature**

CFM	EWB (°F)	95°F EDB			90°F EDB			85°F EDB			80°F EDB			75°F EDB			70°F EDB			65°F EDB		
		TMBH	SMBH	kW	TMBH	SMBH	kW	TMBH	SMBH	kW	TMBH	SMBH	kW	TMBH	SMBH	kW	TMBH	SMBH	kW	TMBH	SMBH	kW
14,000	77	1028	598	56	1030	527	56	1030	459	56	1031	386	56	-	-	-	-	-	-	-	-	-
	72	944	674	56	945	603	56	946	531	56	946	464	56	946	392	56	-	-	-	-	-	-
	67	864	748	55	865	678	55	866	604	55	867	534	55	867	465	55	867	394	55	-	-	-
	62	806	806	55	793	753	55	793	682	55	794	604	55	795	540	55	795	461	55	795	398	55
	57	805	805	55	770	770	54	-	-	-	-	-	-	-	-	-	-	-	-	-	-	-
18,500	77	1108	692	56	1110	596	57	1110	509	57	1110	411	57	-	-	-	-	-	-	-	-	-
	72	1021	790	56	1022	691	56	1023	601	56	1023	510	56	1023	419	56	-	-	-	-	-	-
	67	937	882	56	939	792	56	940	700	56	940	607	56	940	516	56	941	423	56	-	-	-
	62	912	912	55	873	871	55	860	794	55	862	702	55	863	609	55	863	517	55	863	423	55
	57	911	911	55	871	871	55	831	831	55	792	792	55	789	702	55	790	609	55	790	514	55
23,000	77	1157	770	57	1159	664	57	1160	547	57	1162	432	57	-	-	-	-	-	-	-	-	-
	72	1072	898	56	1072	778	56	1073	668	57	1073	551	57	1074	440	57	-	-	-	-	-	-
	67	995	995	56	987	905	56	989	787	56	989	667	56	989	557	56	989	445	56	-	-	-
	62	994	994	56	950	950	56	907	899	55	907	787	56	908	676	56	908	557	56	908	445	56
	57	993	993	56	949	949	56	904	904	55	860	860	55	831	795	55	833	679	55	833	561	55
27,500	77	1192	858	57	1194	716	57	1195	584	57	1197	455	57	-	-	-	-	-	-	-	-	-
	72	1103	995	57	1106	859	57	1107	723	57	1107	592	57	1108	454	57	-	-	-	-	-	-
	67	1060	1060	56	1021	998	56	1023	867	56	1023	729	56	1023	598	57	1022	460	57	-	-	-
	62	1059	1059	56	1011	1011	56	963	963	56	939	875	56	941	737	56	941	601	56	940	465	56
	57	1058	1058	56	1010	1010	56	962	962	56	914	914	56	867	867	55	863	736	56	863	603	56
32,000	77	-	-	-	-	-	-	-	-	-	-	-	-	-	-	-	-	-	-	-	-	-
	72	1124	1094	57	1130	937	57	1132	783	57	1133	628	57	1134	473	57	-	-	-	-	-	-
	67	1112	1112	56	1062	1062	56	1045	947	56	1047	787	57	1048	633	57	1047	479	57	-	-	-
	62	1112	1112	56	1061	1061	56	1010	1010	56	964	953	56	967	794	56	966	642	56	965	483	56
	57	1111	1111	56	1060	1060	56	1010	1010	56	959	959	56	908	908	56	886	797	56	887	643	56

**Table 113: 80 ton standard efficiency - 85°F ambient air temperature**

CFM	EWB (°F)	95°F EDB			90°F EDB			85°F EDB			80°F EDB			75°F EDB			70°F EDB			65°F EDB		
		TMBH	SMBH	kW	TMBH	SMBH	kW	TMBH	SMBH	kW	TMBH	SMBH	kW	TMBH	SMBH	kW	TMBH	SMBH	kW	TMBH	SMBH	kW
14,000	77	994	584	62	995	519	62	995	444	62	995	372	62	-	-	-	-	-	-	-	-	-
	72	912	660	62	912	591	62	913	522	62	914	448	62	914	378	62	-	-	-	-	-	-
	67	833	734	61	834	662	61	835	591	61	836	520	61	837	448	61	837	380	61	-	-	-
	62	781	781	60	761	732	60	762	663	60	763	590	60	763	521	60	765	448	61	764	378	61
	57	780	780	60	749	749	60	-	-	-	-	-	-	-	-	-	-	-	-	-	-	-
18,500	77	1068	678	63	1069	585	63	1070	491	63	1070	396	63	-	-	-	-	-	-	-	-	-
	72	984	770	62	984	684	62	985	588	63	985	491	63	986	404	63	-	-	-	-	-	-
	67	900	874	62	903	778	62	904	682	62	905	593	62	905	497	62	905	407	62	-	-	-
	62	886	886	61	846	845	61	826	778	61	829	683	61	830	594	61	830	497	61	830	407	61
	57	885	885	61	845	845	61	805	805	61	767	765	60	757	691	60	759	595	61	759	499	61
23,000	77	1113	752	63	1115	640	64	1116	528	64	1117	415	64	-	-	-	-	-	-	-	-	-
	72	1029	874	63	1031	760	63	1031	654	63	1032	538	63	1032	423	63	-	-	-	-	-	-
	67	965	965	62	946	888	62	949	767	62	950	650	62	950	543	62	950	427	63	-	-	-
	62	964	964	62	920	920	62	876	876	61	870	772	62	872	658	62	872	543	62	871	427	62
	57	964	964	62	920	920	62	876	876	61	832	832	61	797	776	61	799	660	61	799	546	61
27,500	77	1146	836	64	1147	700	64	1149	574	64	1150	437	64	-	-	-	-	-	-	-	-	-
	72	1059	980	63	1061	846	63	1062	710	63	1063	573	63	1063	440	64	-	-	-	-	-	-
	67	1027	1027	63	982	976	62	981	851	63	981	714	63	981	577	63	981	446	63	-	-	-
	62	1026	1026	63	979	979	62	931	931	62	899	856	62	903	716	62	902	585	62	901	445	62
	57	1025	1025	63	978	978	62	930	930	62	884	884	62	837	837	61	826	721	61	827	586	62
32,000	77	-	-	-	-	-	-	-	-	-	-	-	-	-	-	-	-	-	-	-	-	-
	72	1083	1071	63	1084	920	63	1086	762	63	1087	613	64	1087	457	64	-	-	-	-	-	-
	67	1077	1077	63	1028	1028	63	1002	927	63	1004	775	63	1004	617	63	1004	462	63	-	-	-
	62	1077	1077	63	1027	1027	63	976	976	62	928	923	62	926	777	62	925	624	62	924	462	63
	57	1076	1076	63	1026	1026	63	976	976	62	925	925	62	876	876	62	848	779	62	849	623	62

**Table 114: 80 ton standard efficiency - 95°F ambient air temperature**

CFM	EWB (°F)	95°F EDB			90°F EDB			85°F EDB			80°F EDB			75°F EDB			70°F EDB			65°F EDB		
		TMBH	SMBH	kW	TMBH	SMBH	kW	TMBH	SMBH	kW	TMBH	SMBH	kW	TMBH	SMBH	kW	TMBH	SMBH	kW	TMBH	SMBH	kW
14,000	77	954	570	69	955	498	69	956	426	69	956	358	69	-	-	-	-	-	-	-	-	-
	72	874	647	68	876	572	68	877	501	68	877	435	68	877	363	68	-	-	-	-	-	-
	67	800	721	67	800	648	67	802	575	67	802	507	67	803	430	68	803	365	68	-	-	-
	62	757	757	67	733	715	66	731	647	66	732	578	67	732	504	67	733	433	67	733	362	67
	57	757	757	67	723	723	66	692	692	66	-1	-1	-1	-1	-1	-1	-1	-1	-1	-1	-1	-1
18,500	77	1023	659	70	1024	569	70	1024	470	70	1026	379	70	-	-	-	-	-	-	-	-	-
	72	941	756	69	942	664	69	943	571	69	943	480	69	943	387	69	-	-	-	-	-	-
	67	862	853	68	863	761	68	865	669	68	866	576	68	866	483	68	866	390	69	-	-	-
	62	857	857	68	818	818	68	790	760	67	792	669	67	793	576	68	794	482	68	794	389	68
	57	856	856	68	817	817	67	778	778	67	739	739	67	724	668	67	725	577	67	725	484	67
23,000	77	1065	745	70	1066	629	71	1067	512	71	1067	406	71	-	-	-	-	-	-	-	-	-
	72	982	863	69	985	745	70	985	635	70	986	515	70	986	404	70	-	-	-	-	-	-
	67	932	932	69	903	865	69	906	750	69	907	639	69	907	520	69	907	408	69	-	-	-
	62	931	931	69	888	888	68	845	845	68	831	755	68	832	637	68	832	527	68	832	409	68
	57	930	930	69	887	887	68	844	844	68	802	802	67	761	755	67	760	643	67	763	522	67
27,500	77	-	-	-	-	-	-	-	-	-	-	-	-	-	-	-	-	-	-	-	-	-
	72	1008	964	70	1012	822	70	1013	692	70	1014	557	70	1015	420	70	-	-	-	-	-	-
	67	990	990	69	943	943	69	933	832	69	936	696	69	935	560	69	935	425	70	-	-	-
	62	989	989	69	943	943	69	897	897	69	858	839	68	860	703	68	860	566	69	859	429	69
	57	989	989	69	942	942	69	896	896	69	850	850	68	804	804	68	786	706	68	788	566	68
32,000	77	-	-	-	-	-	-	-	-	-	-	-	-	-	-	-	-	-	-	-	-	-
	72	1040	1037	70	1033	905	70	1035	747	70	1036	595	70	1037	435	71	-	-	-	-	-	-
	67	1038	1038	70	988	988	70	953	911	69	957	755	70	956	597	70	956	440	70	-	-	-
	62	1037	1037	70	988	988	70	939	939	69	890	890	69	880	758	69	881	603	69	880	446	69
	57	1036	1036	70	987	987	69	938	938	69	889	889	69	841	841	68	806	764	68	817	608	68

**Table 115: 80 ton standard efficiency - 105°F ambient air temperature**

CFM	EWB (°F)	95°F EDB			90°F EDB			85°F EDB			80°F EDB			75°F EDB			70°F EDB			65°F EDB		
		TMBH	SMBH	kW	TMBH	SMBH	kW	TMBH	SMBH	kW	TMBH	SMBH	kW	TMBH	SMBH	kW	TMBH	SMBH	kW	TMBH	SMBH	kW
14,000	77	911	554	76	912	485	76	913	416	76	913	342	76	-	-	-	-	-	-	-	-	-
	72	835	626	75	836	555	75	837	487	75	837	415	75	837	343	75	-	-	-	-	-	-
	67	762	699	74	764	630	74	765	561	74	766	488	74	766	418	74	766	348	75	-	-	-
	62	731	731	74	704	693	73	697	631	73	698	558	73	699	488	73	699	417	73	700	346	74
	57	730	730	74	697	697	73	667	667	73	638	632	72	638	562	72	639	486	72	639	416	73
18,500	77	973	637	77	974	551	77	975	457	77	975	361	77	-	-	-	-	-	-	-	-	-
	72	894	735	76	897	641	76	898	553	76	898	457	76	899	369	77	-	-	-	-	-	-
	67	828	822	75	820	739	75	822	645	75	823	557	75	824	460	75	824	371	76	-	-	-
	62	825	825	75	786	786	74	752	745	74	752	649	74	754	555	74	755	466	74	755	370	75
	57	824	824	75	786	786	74	748	748	74	710	710	73	687	654	73	688	561	73	690	461	73
23,000	77	1011	717	78	1012	607	78	1014	497	78	1015	386	78	-	-	-	-	-	-	-	-	-
	72	930	845	77	935	727	77	936	612	77	936	499	77	936	385	77	-	-	-	-	-	-
	67	895	895	76	859	844	76	859	736	76	861	616	76	861	502	76	861	389	76	-	-	-
	62	895	895	76	853	853	75	811	811	75	786	738	75	789	620	75	789	508	75	788	388	75
	57	894	894	76	852	852	75	810	810	75	768	768	74	727	727	74	721	624	74	723	508	74
27,500	77	-	-	-	-	-	-	-	-	-	-	-	-	-	-	-	-	-	-	-	-	-
	72	958	936	77	959	807	77	961	670	77	962	538	77	962	404	78	-	-	-	-	-	-
	67	950	950	77	904	904	76	884	814	76	887	677	76	887	540	77	886	408	77	-	-	-
	62	949	949	77	904	904	76	859	859	76	816	811	75	813	681	75	815	545	76	814	407	76
	57	948	948	77	903	903	76	858	858	76	813	813	75	769	769	75	744	685	74	746	543	75
32,000	77	-	-	-	-	-	-	-	-	-	-	-	-	-	-	-	-	-	-	-	-	-
	72	995	995	77	977	885	77	981	728	78	981	573	78	981	419	78	-	-	-	-	-	-
	67	994	994	77	946	946	77	903	890	76	906	732	77	905	574	77	905	423	77	-	-	-
	62	993	993	77	945	945	77	898	898	76	851	851	76	831	745	76	834	579	76	832	422	76
	57	992	992	77	945	945	77	897	897	76	850	850	76	803	803	75	761	745	75	764	582	75

**Table 116: 80 ton standard efficiency - 115°F ambient air temperature**

CFM	EWB (°F)	95°F EDB			90°F EDB			85°F EDB			80°F EDB			75°F EDB			70°F EDB			65°F EDB		
		TMBH	SMBH	kW	TMBH	SMBH	kW	TMBH	SMBH	kW	TMBH	SMBH	kW	TMBH	SMBH	kW	TMBH	SMBH	kW	TMBH	SMBH	kW
14,000	77	864	538	84	865	465	84	865	394	84	866	324	84	-	-	-	-	-	-	-	-	-
	72	791	610	83	792	538	83	793	466	83	794	394	83	794	326	83	-	-	-	-	-	-
	67	722	684	82	724	612	82	725	543	82	726	470	82	726	397	82	727	327	82	-	-	-
	62	702	702	81	672	666	81	661	613	81	662	542	81	662	469	81	663	399	81	663	328	81
	57	701	701	81	669	669	81	637	637	80	609	602	80	355	327	45	603	467	80	356	235	45
18,500	77	920	620	85	921	530	85	922	440	85	920	341	85	-	-	-	-	-	-	-	-	-
	72	844	718	84	846	629	84	848	531	84	848	439	84	849	348	84	-	-	-	-	-	-
	67	791	789	83	774	727	83	776	631	83	777	533	83	778	441	83	778	350	83	-	-	-
	62	790	790	83	752	752	82	717	713	82	709	633	82	711	537	82	713	447	82	713	349	82
	57	789	789	83	752	752	82	715	715	82	678	678	81	649	630	81	650	541	81	651	446	81
23,000	77	-	-	-	-	-	-	-	-	-	-	-	-	-	-	-	-	-	-	-	-	-
	72	876	823	84	880	710	84	882	595	85	883	479	85	882	363	85	-	-	-	-	-	-
	67	855	855	84	815	815	83	808	717	83	811	597	84	812	481	84	812	366	84	-	-	-
	62	855	855	84	814	814	83	773	773	83	746	720	82	742	599	82	744	486	83	743	372	83
	57	854	854	84	813	813	83	772	772	83	732	732	82	692	692	81	678	602	81	680	485	82
27,500	77	-	-	-	-	-	-	-	-	-	-	-	-	-	-	-	-	-	-	-	-	-
	72	907	907	85	900	788	85	905	649	85	905	514	85	905	384	86	-	-	-	-	-	-
	67	905	905	85	862	862	84	830	794	84	833	656	84	835	520	84	834	387	84	-	-	-
	62	905	905	85	861	861	84	817	817	83	774	774	83	764	663	83	767	520	83	765	386	83
	57	905	905	85	861	861	84	817	817	83	774	774	83	731	731	82	699	665	82	701	521	82
32,000	77	-	-	-	-	-	-	-	-	-	-	-	-	-	-	-	-	-	-	-	-	-
	72	-	-	-	915	865	85	921	708	85	922	548	86	922	397	86	-	-	-	-	-	-
	67	-	-	-	900	900	85	855	852	84	850	712	84	851	557	85	850	400	85	-	-	-
	62	-	-	-	900	900	85	854	854	84	808	808	83	781	723	83	783	557	83	781	404	84
	57	-	-	-	899	899	85	853	853	84	807	807	83	762	762	83	718	714	82	717	560	82

**Table 117: 80 ton standard efficiency - 125°F ambient air temperature**

CFM	EWB (°F)	95°F EDB			90°F EDB			85°F EDB			80°F EDB			75°F EDB			70°F EDB			65°F EDB		
		TMBH	SMBH	kW	TMBH	SMBH	kW	TMBH	SMBH	kW	TMBH	SMBH	kW	TMBH	SMBH	kW	TMBH	SMBH	kW	TMBH	SMBH	kW
14,000	77	811	518	92	813	445	93	814	376	93	814	305	93	-	-	-	-	-	-	-	-	-
	72	743	588	91	744	521	91	746	450	91	747	378	92	747	306	92	-	-	-	-	-	-
	67	682	659	90	680	592	90	681	521	90	682	453	90	683	380	90	683	308	90	-	-	-
	62	670	670	90	639	639	89	621	594	89	622	523	89	623	450	89	623	381	89	624	306	89
	57	670	670	90	638	638	89	607	607	88	577	575	88	566	521	88	567	450	88	568	376	88
18,500	77	861	603	93	863	509	94	864	415	94	864	327	94	-	-	-	-	-	-	-	-	-
	72	789	702	92	791	610	92	793	512	92	795	419	93	796	326	93	-	-	-	-	-	-
	67	752	752	91	724	702	91	726	611	91	728	514	91	729	421	91	729	328	92	-	-	-
	62	751	751	91	715	715	91	680	679	90	665	613	90	665	521	90	667	425	90	667	327	90
	57	750	750	91	715	715	91	679	679	90	643	643	89	610	606	89	608	519	89	609	424	89
23,000	77	-	-	-	-	-	-	-	-	-	-	-	-	-	-	-	-	-	-	-	-	-
	72	820	799	93	820	687	93	824	573	93	825	456	93	825	347	94	-	-	-	-	-	-
	67	811	811	92	772	772	92	755	693	92	756	580	92	759	459	92	758	349	92	-	-	-
	62	811	811	92	771	771	92	733	733	91	694	694	90	693	580	91	695	462	91	694	348	91
	57	809	809	92	771	771	92	732	732	91	693	693	90	654	654	90	633	582	89	634	466	90
27,500	77	-	-	-	-	-	-	-	-	-	-	-	-	-	-	-	-	-	-	-	-	-
	72	858	858	93	840	769	93	843	630	93	845	493	94	845	358	94	-	-	-	-	-	-
	67	858	858	93	815	815	93	777	764	92	775	641	92	779	497	93	778	361	93	-	-	-
	62	857	857	93	815	815	93	773	773	92	731	731	91	712	642	91	715	499	91	714	364	92
	57	856	856	93	814	814	92	772	772	92	731	731	91	690	690	90	652	641	90	653	505	90
32,000	77	-	-	-	-	-	-	-	-	-	-	-	-	-	-	-	-	-	-	-	-	-
	72	-	-	-	855	843	93	856	684	94	860	528	94	860	376	94	-	-	-	-	-	-
	67	-	-	-	850	850	93	806	806	93	788	698	92	793	533	93	794	379	93	-	-	-
	62	-	-	-	849	849	93	806	806	93	762	762	92	725	700	91	728	538	92	728	377	92
	57	-	-	-	849	849	93	805	805	92	761	761	92	718	718	91	675	675	90	666	545	90

**Notes:**

Rated performance is at sea level. Cooling capacities are gross cooling capacities.  
 CFM = airflow, EWB = entering wet bulb air, EDB = entering dry bulb air, TMBH = total cooling capacity (MBH)  
 SMBH = sensible cooling capacity (MBH), kW = total input

## Cooling performance data 80 ton high efficiency

**Table 118: 80 ton high efficiency - 75°F ambient air temperature**

CFM	EWB (°F)	95°F EDB			90°F EDB			85°F EDB			80°F EDB			75°F EDB			70°F EDB			65°F EDB		
		TMBH	SMBH	kW	TMBH	SMBH	kW	TMBH	SMBH	kW	TMBH	SMBH	kW	TMBH	SMBH	kW	TMBH	SMBH	kW	TMBH	SMBH	kW
14,000	77	1025	602	56	1026	529	56	1027	458	56	1028	384	56	-	-	-	-	-	-	-	-	-
	72	941	672	56	942	601	56	942	529	56	943	462	56	943	390	56	-	-	-	-	-	-
	67	862	746	55	863	676	55	863	602	55	864	537	55	864	463	55	864	392	55	-	-	-
	62	805	805	55	791	752	55	792	681	55	792	610	55	792	539	55	793	468	55	793	396	55
	57	804	804	55	-	-	-	-	-	-	-	-	-	-	-	-	-	-	-	-	-	-
18,500	77	1066	676	63	1067	584	63	1069	490	63	1069	395	63	-	-	-	-	-	-	-	-	-
	72	980	776	62	982	682	62	983	587	62	984	491	62	984	404	62	-	-	-	-	-	-
	67	901	867	61	900	777	62	902	680	62	902	592	62	903	495	62	904	407	62	-	-	-
	62	884	884	61	845	843	61	826	778	61	827	682	61	828	593	61	828	503	61	828	406	61
	57	884	884	61	844	844	61	804	804	61	766	766	60	757	689	60	758	591	60	758	500	60
23,000	77	1112	756	63	1114	646	63	1116	536	64	1116	413	64	-	-	-	-	-	-	-	-	-
	72	1026	880	63	1029	767	63	1030	654	63	1031	537	63	1032	423	63	-	-	-	-	-	-
	67	964	964	62	945	885	62	946	772	62	948	658	62	949	542	62	949	427	62	-	-	-
	62	963	963	62	919	919	62	875	875	61	868	771	61	870	656	62	871	542	62	871	427	62
	57	962	962	62	918	918	62	874	874	61	831	831	61	797	770	61	797	658	61	798	545	61
27,500	77	-	-	-	-	-	-	-	-	-	-	-	-	-	-	-	-	-	-	-	-	-
	72	1056	978	63	1059	844	63	1061	710	63	1062	572	63	1062	440	63	-	-	-	-	-	-
	67	1026	1026	63	983	972	62	977	852	62	979	718	62	981	577	63	980	445	63	-	-	-
	62	1024	1024	63	977	977	62	930	930	62	899	852	62	900	718	62	902	585	62	901	445	62
	57	1024	1024	63	976	976	62	929	929	62	882	882	61	836	836	61	824	723	61	825	585	61
32,000	77	-	-	-	-	-	-	-	-	-	-	-	-	-	-	-	-	-	-	-	-	-
	72	1082	1069	63	1081	926	63	1085	761	63	1086	613	63	1086	456	64	-	-	-	-	-	-
	67	1076	1076	63	1026	1026	63	998	934	63	1003	774	63	1004	617	63	1004	462	63	-	-	-
	62	1075	1075	63	1025	1025	63	975	975	62	927	919	62	923	777	62	925	624	62	923	461	62
	57	1074	1074	63	1024	1024	63	974	974	62	925	925	62	875	875	62	846	780	61	848	623	62

**Table 119: 80 ton high efficiency - 85°F ambient air temperature**

CFM	EWB (°F)	95°F EDB			90°F EDB			85°F EDB			80°F EDB			75°F EDB			70°F EDB			65°F EDB		
		TMBH	SMBH	kW	TMBH	SMBH	kW	TMBH	SMBH	kW	TMBH	SMBH	kW	TMBH	SMBH	kW	TMBH	SMBH	kW	TMBH	SMBH	kW
14,000	77	991	582	62	992	518	62	993	443	62	993	372	62	-	-	-	-	-	-	-	-	-
	72	909	658	62	910	590	62	911	521	62	911	446	62	911	377	62	-	-	-	-	-	-
	67	832	734	61	833	666	61	834	590	61	834	519	61	835	448	61	834	379	61	-	-	-
	62	783	783	60	764	733	60	764	665	60	765	589	60	765	520	60	765	451	60	765	383	60
	57	782	782	60	748	748	60	-	-	-	-	-	-	-	-	-	-	-	-	-	-	-
18,500	77	1066	676	63	1067	584	63	1069	490	63	1069	395	63	-	-	-	-	-	-	-	-	-
	72	980	776	62	982	682	62	983	587	62	984	491	62	984	404	62	-	-	-	-	-	-
	67	901	867	61	900	777	62	902	680	62	902	592	62	903	495	62	904	407	62	-	-	-
	62	884	884	61	845	843	61	826	778	61	827	682	61	828	593	61	828	503	61	828	406	61
	57	884	884	61	844	844	61	804	804	61	766	766	60	757	689	60	758	591	60	758	500	60
23,000	77	1112	756	63	1114	646	63	1116	536	64	1116	413	64	-	-	-	-	-	-	-	-	-
	72	1026	880	63	1029	767	63	1030	654	63	1031	537	63	1032	423	63	-	-	-	-	-	-
	67	964	964	62	945	885	62	946	772	62	948	658	62	949	542	62	949	427	62	-	-	-
	62	963	963	62	919	919	62	875	875	61	868	771	61	870	656	62	871	542	62	871	427	62
	57	962	962	62	918	918	62	874	874	61	831	831	61	797	770	61	797	658	61	798	545	61
27,500	77	-	-	-	-	-	-	-	-	-	-	-	-	-	-	-	-	-	-	-	-	-
	72	1056	978	63	1059	844	63	1061	710	63	1062	572	63	1062	440	63	-	-	-	-	-	-
	67	1026	1026	63	983	972	62	977	852	62	979	718	62	981	577	63	980	445	63	-	-	-
	62	1024	1024	63	977	977	62	930	930	62	899	852	62	900	718	62	902	585	62	901	445	62
	57	1024	1024	63	976	976	62	929	929	62	882	882	61	836	836	61	824	723	61	825	585	61
32,000	77	-	-	-	-	-	-	-	-	-	-	-	-	-	-	-	-	-	-	-	-	-
	72	1082	1069	63	1081	926	63	1085	761	63	1086	613	63	1086	456	64	-	-	-	-	-	-
	67	1076	1076	63	1026	1026	63	998	934	63	1003	774	63	1004	617	63	1004	462	63	-	-	-
	62	1075	1075	63	1025	1025	63	975	975	62	927	919	62	923	777	62	925	624	62	923	461	62
	57	1074	1074	63	1024	1024	63	974	974	62	925	925	62	875	875	62	846	780	61	848	623	62

**Table 120: 80 ton high efficiency - 95°F ambient air temperature**

CFM	EWB (°F)	95°F EDB			90°F EDB			85°F EDB			80°F EDB			75°F EDB			70°F EDB			65°F EDB		
		TMBH	SMBH	kW	TMBH	SMBH	kW	TMBH	SMBH	kW	TMBH	SMBH	kW	TMBH	SMBH	kW	TMBH	SMBH	kW	TMBH	SMBH	kW
14,000	77	953	569	69	954	498	69	955	430	69	955	357	69	-	-	-	-	-	-	-	-	-
	72	874	646	68	875	572	68	876	501	68	876	434	68	876	363	68	-	-	-	-	-	-
	67	800	713	67	801	648	67	801	575	67	802	506	67	802	433	67	802	364	67	-	-	-
	62	757	757	66	733	715	66	731	648	66	732	573	66	732	504	66	732	436	66	732	362	66
	57	756	756	66	725	725	66	-	-	-	-	-	-	-	-	-	-	-	-	-	-	-
18,500	77	1021	658	70	1023	569	70	1024	470	70	1025	379	70	-	-	-	-	-	-	-	-	-
	72	939	754	69	941	663	69	942	571	69	943	480	69	944	387	69	-	-	-	-	-	-
	67	865	848	68	862	761	68	864	668	68	866	576	68	865	482	68	866	390	68	-	-	-
	62	856	856	68	817	817	67	792	762	67	792	668	67	793	575	67	793	483	67	793	389	67
	57	856	856	68	816	816	67	778	778	67	740	740	66	725	667	66	725	580	66	726	486	66
23,000	77	-	-	-	-	-	-	1067	512	70	1069	406	70	-	-	-	-	-	-	-	-	-
	72	981	862	69	983	745	69	984	634	69	986	516	69	986	404	70	-	-	-	-	-	-
	67	932	932	68	903	864	68	905	750	68	906	638	69	908	520	69	908	408	69	-	-	-
	62	931	931	68	887	887	68	844	844	68	830	753	68	831	643	68	831	526	68	832	409	68
	57	930	930	68	887	887	68	844	844	68	801	801	67	763	750	67	761	644	67	762	528	67
27,500	77	-	-	-	-	-	-	-	-	-	-	-	-	-	-	-	-	-	-	-	-	-
	72	1008	960	69	1011	826	70	1014	692	70	1014	557	70	1015	421	70	-	-	-	-	-	-
	67	990	990	69	943	943	69	933	837	69	936	695	69	937	561	69	936	425	69	-	-	-
	62	989	989	69	942	942	69	896	896	68	859	831	68	859	702	68	860	567	68	860	430	68
	57	988	988	69	942	942	69	896	896	68	850	850	68	804	804	67	786	705	67	787	566	67
32,000	77	-	-	-	-	-	-	-	-	-	-	-	-	-	-	-	-	-	-	-	-	-
	72	1040	1034	70	1031	903	70	1035	747	70	1037	595	70	1037	436	70	-	-	-	-	-	-
	67	1037	1037	70	988	988	69	954	905	69	956	754	69	958	598	69	957	440	70	-	-	-
	62	1036	1036	70	988	988	69	938	938	69	890	888	68	879	764	68	882	604	69	880	446	69
	57	1036	1036	70	987	987	69	938	938	69	889	889	68	840	840	68	806	765	67	808	601	68

**Table 121: 80 ton high efficiency - 105°F ambient air temperature**

CFM	EWB (°F)	95°F EDB			90°F EDB			85°F EDB			80°F EDB			75°F EDB			70°F EDB			65°F EDB		
		TMBH	SMBH	kW	TMBH	SMBH	kW	TMBH	SMBH	kW	TMBH	SMBH	kW	TMBH	SMBH	kW	TMBH	SMBH	kW	TMBH	SMBH	kW
14,000	77	911	553	76	912	485	76	913	416	76	914	342	76	-	-	-	-	-	-	-	-	-
	72	835	626	75	836	555	75	837	487	75	838	415	75	838	347	75	-	-	-	-	-	-
	67	764	701	74	765	631	74	766	559	74	766	489	74	766	418	74	767	345	74	-	-	-
	62	731	731	73	705	690	73	699	630	73	699	559	73	699	488	73	700	417	73	700	346	73
	57	730	730	73	697	697	73	667	667	72	-	-	-	-	-	-	-	-	-	-	-	-
18,500	77	973	645	77	974	551	77	976	457	77	977	362	77	-	-	-	-	-	-	-	-	-
	72	894	735	76	896	648	76	898	553	76	898	465	76	900	369	76	-	-	-	-	-	-
	67	828	823	75	821	741	75	823	653	75	826	558	75	824	460	75	825	371	75	-	-	-
	62	825	825	74	787	787	74	755	741	74	754	651	74	755	555	74	755	466	74	755	370	74
	57	824	824	74	786	786	74	748	748	73	710	710	73	689	649	73	690	556	73	690	467	73
23,000	77	-	-	-	-	-	-	-	-	-	-	-	-	-	-	-	-	-	-	-	-	-
	72	932	847	76	934	726	76	936	614	76	938	500	76	938	386	77	-	-	-	-	-	-
	67	896	896	75	862	840	75	859	737	75	862	617	75	862	503	75	863	389	76	-	-	-
	62	895	895	75	853	853	75	811	811	74	788	739	74	789	620	74	790	508	75	790	388	75
	57	894	894	75	852	852	75	810	810	74	769	769	74	727	727	73	722	625	73	723	508	74
27,500	77	-	-	-	-	-	-	-	-	-	-	-	-	-	-	-	-	-	-	-	-	-
	72	960	938	76	959	807	77	962	676	77	963	538	77	964	405	77	-	-	-	-	-	-
	67	950	950	76	905	905	76	884	814	76	887	681	76	889	541	76	888	409	76	-	-	-
	62	949	949	76	905	905	76	860	860	75	818	809	75	814	682	75	815	545	75	815	408	75
	57	949	949	76	904	904	76	859	859	75	814	814	75	770	770	74	744	683	74	746	547	74
32,000	77	-	-	-	-	-	-	-	-	-	-	-	-	-	-	-	-	-	-	-	-	-
	72	-	-	-	976	884	77	979	733	77	982	574	77	984	420	77	-	-	-	-	-	-
	67	-	-	-	947	947	76	907	888	76	905	741	76	907	576	76	907	424	76	-	-	-
	62	-	-	-	946	946	76	899	899	76	852	852	75	833	740	75	835	580	75	834	423	76
	57	-	-	-	945	945	76	898	898	76	851	851	75	804	804	75	764	740	74	764	584	74

**Table 122: 80 ton high efficiency - 115°F ambient air temperature**

CFM	EWB (°F)	95°F EDB			90°F EDB			85°F EDB			80°F EDB			75°F EDB			70°F EDB			65°F EDB		
		TMBH	SMBH	kW	TMBH	SMBH	kW	TMBH	SMBH	kW	TMBH	SMBH	kW	TMBH	SMBH	kW	TMBH	SMBH	kW	TMBH	SMBH	kW
14,000	77	866	536	83	866	466	83	867	395	83	867	324	83	-	-	-	-	-	-	-	-	-
	72	793	607	82	794	539	82	795	467	82	795	399	82	796	326	82	-	-	-	-	-	-
	67	726	681	81	727	611	81	727	541	81	728	471	81	728	397	81	728	328	81	-	-	-
	62	703	703	80	674	666	80	663	611	80	664	541	80	664	470	80	664	400	80	665	328	80
	57	702	702	80	670	670	80	640	640	79	609	609	79	607	540	79	607	468	79	607	401	79
18,500	77	921	621	84	922	531	84	925	441	84	925	342	85	-	-	-	-	-	-	-	-	-
	72	846	719	83	847	630	83	849	531	83	850	441	83	851	349	83	-	-	-	-	-	-
	67	793	790	82	777	722	82	778	632	82	779	541	82	780	442	82	780	351	82	-	-	-
	62	791	791	82	754	754	81	719	714	81	713	630	81	714	539	81	714	448	81	715	350	81
	57	790	790	82	753	753	81	716	716	81	679	679	80	89	82	11	652	538	80	652	447	80
23,000	77	-	-	-	-	-	-	-	-	-	-	-	-	-	-	-	-	-	-	-	-	-
	72	879	825	83	881	712	84	884	597	84	885	480	84	886	364	84	-	-	-	-	-	-
	67	857	857	83	816	816	82	811	712	83	812	598	83	814	483	83	815	368	83	-	-	-
	62	856	856	83	815	815	82	775	775	82	745	713	81	745	600	82	746	487	82	745	373	82
	57	856	856	83	815	815	82	774	774	82	734	734	81	694	694	81	682	605	81	682	487	81
27,500	77	-	-	-	-	-	-	-	-	-	-	-	-	-	-	-	-	-	-	-	-	-
	72	908	908	84	903	791	84	906	655	84	908	516	84	909	386	85	-	-	-	-	-	-
	67	908	908	84	863	863	83	833	793	83	836	658	83	837	521	83	837	385	84	-	-	-
	62	907	907	84	863	863	83	819	819	83	776	776	82	767	661	82	770	522	82	768	387	83
	57	906	906	84	862	862	83	819	819	83	776	776	82	732	732	81	702	665	81	703	526	81
32,000	77	-	-	-	-	-	-	-	-	-	-	-	-	-	-	-	-	-	-	-	-	-
	72	-	-	-	920	864	84	924	710	84	926	550	85	926	398	85	-	-	-	-	-	-
	67	-	-	-	903	903	84	858	853	83	851	714	83	855	559	84	854	399	84	-	-	-
	62	-	-	-	901	901	84	856	856	83	810	810	83	782	724	82	786	559	83	785	406	83
	57	-	-	-	901	901	84	855	855	83	810	810	83	764	764	82	721	715	81	719	562	82

**Table 123: 80 ton high efficiency - 125°F ambient air temperature**

CFM	EWB (°F)	95°F EDB			90°F EDB			85°F EDB			80°F EDB			75°F EDB			70°F EDB			65°F EDB		
		TMBH	SMBH	kW	TMBH	SMBH	kW	TMBH	SMBH	kW	TMBH	SMBH	kW	TMBH	SMBH	kW	TMBH	SMBH	kW	TMBH	SMBH	kW
14,000	77	814	521	91	815	447	91	817	377	92	817	306	92	-	-	-	-	-	-	-	-	-
	72	747	591	90	748	523	90	749	447	90	749	379	90	750	308	90	-	-	-	-	-	-
	67	684	662	89	684	593	89	685	520	89	686	451	89	686	378	89	686	309	89	-	-	-
	62	672	672	89	641	641	88	625	592	88	626	523	88	626	453	88	626	383	88	626	307	88
	57	671	671	89	640	640	88	609	609	87	580	575	87	569	519	87	570	450	87	570	377	87
18,500	77	-	-	-	-	-	-	-	-	-	-	-	-	-	-	-	-	-	-	-	-	-
	72	793	698	91	795	607	91	796	513	91	798	421	91	799	328	92	-	-	-	-	-	-
	67	754	754	90	730	701	90	730	607	90	730	515	90	732	422	90	732	330	90	-	-	-
	62	753	753	90	717	717	90	682	681	89	668	609	89	669	518	89	670	427	89	670	334	89
	57	753	753	90	717	717	90	681	681	89	646	646	88	613	607	88	612	517	88	612	426	88
23,000	77	-	-	-	-	-	-	-	-	-	-	-	-	-	-	-	-	-	-	-	-	-
	72	824	799	91	824	691	92	826	575	92	829	459	92	829	348	92	-	-	-	-	-	-
	67	814	814	91	774	774	91	758	690	91	760	576	91	763	461	91	763	351	91	-	-	-
	62	813	813	91	774	774	91	735	735	90	699	687	89	696	582	90	697	463	90	698	350	90
	57	813	813	91	773	773	91	734	734	90	695	695	89	656	656	89	637	584	88	638	468	89
27,500	77	-	-	-	-	-	-	-	-	-	-	-	-	-	-	-	-	-	-	-	-	-
	72	-	-	-	843	772	92	846	632	92	849	499	93	850	361	93	-	-	-	-	-	-
	67	-	-	-	818	818	91	781	768	91	780	637	91	783	500	91	783	363	92	-	-	-
	62	-	-	-	817	817	91	776	776	91	734	734	90	716	641	90	717	504	90	718	366	91
	57	-	-	-	817	817	91	775	775	91	734	734	90	692	692	89	656	641	89	656	504	89
32,000	77	-	-	-	-	-	-	-	-	-	-	-	-	-	-	-	-	-	-	-	-	-
	72	-	-	-	241	229	24	860	687	93	864	531	93	865	378	93	-	-	-	-	-	-
	67	-	-	-	236	236	24	809	809	91	793	695	91	797	535	92	798	381	92	-	-	-
	62	-	-	-	236	236	24	809	809	91	765	765	91	730	700	90	732	543	91	732	379	91
	57	-	-	-	236	236	24	808	808	91	764	764	91	721	721	90	678	678	89	670	542	89

**Notes:**

Rated performance is at sea level. Cooling capacities are gross cooling capacities.  
 CFM = airflow, EWB = entering wet bulb air, EDB = entering dry bulb air, TMBH = total cooling capacity (MBH)  
 SMBH = sensible cooling capacity (MBH), kW = total input

# Cooling performance data 80 ton high capacity

**Table 124: 80 ton high capacity - 75°F ambient air temperature**

CFM	EWB (°F)	95°F EDB			90°F EDB			85°F EDB			80°F EDB			75°F EDB			70°F EDB			65°F EDB		
		TMBH	SMBH	kW	TMBH	SMBH	kW	TMBH	SMBH	kW	TMBH	SMBH	kW	TMBH	SMBH	kW	TMBH	SMBH	kW	TMBH	SMBH	kW
14,000	77	1071	619	61	1072	549	61	1073	479	61	1073	408	61	-	-	-	-	-	-	-	-	-
	72	983	692	60	985	622	60	985	553	60	986	483	60	985	408	60	-	-	-	-	-	-
	67	901	765	60	901	697	60	902	624	60	903	552	60	903	484	60	903	410	60	-	-	-
	62	832	832	59	827	769	59	828	695	59	828	629	59	-	-	-	-	-	-	-	-	-
	57	832	832	59	-	-	-	-	-	-	-	-	-	-	-	-	-	-	-	-	-	-
18,500	77	1158	713	61	1160	623	62	1161	523	62	1161	431	62	-	-	-	-	-	-	-	-	-
	72	1068	806	61	1069	712	61	1069	628	61	1069	533	61	1071	439	61	-	-	-	-	-	-
	67	980	903	60	982	810	60	982	722	61	983	626	61	984	531	61	984	443	61	-	-	-
	62	944	944	60	905	901	60	900	813	60	902	726	60	903	629	60	903	541	60	903	442	60
	57	944	944	60	903	903	60	862	862	59	-	-	-	-	-	-	-	-	-	-	-	-
23,000	77	1212	793	62	1214	683	62	1215	573	62	1216	450	62	-	-	-	-	-	-	-	-	-
	72	1123	918	61	1124	803	61	1125	689	62	1125	576	62	1126	461	62	-	-	-	-	-	-
	67	1034	1025	61	1034	919	61	1036	803	61	1036	688	61	1036	582	61	1037	466	61	-	-	-
	62	1031	1031	61	985	985	60	950	926	60	952	806	60	952	698	60	952	582	61	952	467	61
	57	1031	1031	61	985	985	60	939	939	60	894	894	60	872	811	60	874	700	60	875	586	60
27,500	77	1250	872	62	1252	737	62	1254	607	62	1256	470	62	-	-	-	-	-	-	-	-	-
	72	1158	1016	62	1160	879	62	1160	746	62	1162	614	62	1163	477	62	-	-	-	-	-	-
	67	1100	1100	61	1069	1028	61	1073	888	61	1074	755	61	1074	617	61	1074	483	62	-	-	-
	62	1099	1099	61	1050	1050	61	1001	1001	61	987	896	61	988	754	61	988	621	61	988	484	61
	57	1098	1098	61	1050	1050	61	1000	1000	61	951	951	60	902	902	60	891	787	60	892	650	60
32,000	77	-	-	-	-	-	-	1283	642	62	1284	488	63	-	-	-	-	-	-	-	-	-
	72	1183	1116	62	1188	961	62	1190	802	62	1191	652	62	1191	497	62	-	-	-	-	-	-
	67	1157	1157	61	1106	1103	61	1100	967	61	1101	808	62	1101	655	62	1101	504	62	-	-	-
	62	1156	1156	61	1104	1104	61	1052	1052	61	1013	978	61	1017	815	61	1019	659	61	1016	505	61
	57	1155	1155	61	1104	1104	61	1052	1052	61	999	999	61	948	948	60	933	821	61	933	663	61

**Table 125: 80 ton high capacity - 85°F ambient air temperature**

CFM	EWB (°F)	95°F EDB			90°F EDB			85°F EDB			80°F EDB			75°F EDB			70°F EDB			65°F EDB		
		TMBH	SMBH	kW	TMBH	SMBH	kW	TMBH	SMBH	kW	TMBH	SMBH	kW	TMBH	SMBH	kW	TMBH	SMBH	kW	TMBH	SMBH	kW
14,000	77	1036	603	68	1036	535	68	1037	462	68	1037	388	68	-	-	-	-	-	-	-	-	-
	72	950	678	67	951	606	67	952	535	67	953	467	67	952	394	67	-	-	-	-	-	-
	67	869	752	66	871	679	66	871	608	66	871	542	66	872	467	66	872	396	66	-	-	-
	62	810	810	65	798	750	65	798	678	65	799	607	65	799	535	65	799	471	65	799	400	66
	57	809	809	65	-	-	-	-	-	-	-	-	-	-	-	-	-	-	-	-	-	-
18,500	77	1116	697	69	1118	600	69	1119	513	69	1120	414	69	-	-	-	-	-	-	-	-	-
	72	1028	786	68	1029	696	68	1030	605	68	1030	514	68	1031	423	68	-	-	-	-	-	-
	67	943	888	67	945	796	67	946	704	67	946	613	67	947	519	67	947	426	67	-	-	-
	62	917	917	67	878	874	66	866	799	66	868	707	66	869	613	66	869	520	66	869	426	67
	57	917	917	67	876	876	66	836	836	66	796	796	65	794	707	65	795	612	66	795	517	66
23,000	77	1166	777	69	1169	660	69	1169	551	69	1171	435	69	-	-	-	-	-	-	-	-	-
	72	1079	895	68	1081	784	69	1081	673	69	1082	555	69	1083	444	69	-	-	-	-	-	-
	67	1001	1001	68	992	902	68	995	792	68	996	671	68	996	571	68	996	448	68	-	-	-
	62	1000	1000	68	955	955	67	914	906	67	913	792	67	915	681	67	915	571	67	914	448	67
	57	1000	1000	68	955	955	67	910	910	67	866	866	66	837	795	66	839	680	66	840	563	66
27,500	77	1201	853	69	1203	722	70	1205	589	70	1207	459	70	-	-	-	-	-	-	-	-	-
	72	1112	1002	69	1114	866	69	1115	728	69	1116	596	69	1116	458	69	-	-	-	-	-	-
	67	1067	1067	68	1027	1004	68	1030	873	68	1031	735	68	1031	602	68	1031	464	68	-	-	-
	62	1066	1066	68	1017	1017	68	969	969	67	945	877	67	948	743	67	948	605	68	947	468	68
	57	1066	1066	68	1017	1017	68	969	969	67	921	921	67	873	873	66	869	739	67	870	600	67
32,000	77	-	-	-	-	-	-	-	-	-	-	-	-	-	-	-	-	-	-	-	-	-
	72	1133	1103	69	1140	945	69	1142	789	69	1142	633	69	1143	477	70	-	-	-	-	-	-
	67	1120	1120	69	1069	1069	68	1054	947	68	1056	794	69	1057	638	69	1057	483	69	-	-	-
	62	1120	1120	69	1068	1068	68	1017	1017	68	971	958	67	974	800	68	974	640	68	973	487	68
	57	1120	1120	69	1068	1068	68	1017	1017	68	965	965	67	915	915	67	893	804	67	894	644	67

**Table 126: 80 ton high capacity - 95°F ambient air temperature**

CFM	EWB (°F)	95°F EDB			90°F EDB			85°F EDB			80°F EDB			75°F EDB			70°F EDB			65°F EDB		
		TMBH	SMBH	kW	TMBH	SMBH	kW	TMBH	SMBH	kW	TMBH	SMBH	kW	TMBH	SMBH	kW	TMBH	SMBH	kW	TMBH	SMBH	kW
14,000	77	995	585	75	996	520	75	997	444	75	997	373	75	-	-	-	-	-	-	-	-	-
	72	913	660	74	914	592	74	915	523	74	915	449	74	916	379	74	-	-	-	-	-	-
	67	835	736	73	836	660	73	837	592	73	837	521	73	837	449	73	838	380	73	-	-	-
	62	786	786	72	766	735	72	766	667	72	767	591	72	768	522	72	768	453	72	768	384	72
	57	784	784	72	750	750	72	-	-	-	-	-	-	-	-	-	-	-	-	-	-	-
18,500	77	1070	679	76	1071	586	76	1072	492	76	1073	397	76	-	-	-	-	-	-	-	-	-
	72	984	771	75	986	676	75	987	589	75	987	492	75	988	405	75	-	-	-	-	-	-
	67	902	875	74	905	780	74	906	683	74	907	595	74	908	498	74	907	408	74	-	-	-
	62	887	887	74	848	847	73	828	780	73	830	692	73	831	595	73	832	498	73	832	408	73
	57	887	887	74	848	848	73	808	808	73	768	768	72	760	691	72	761	594	72	761	502	72
23,000	77	1115	754	77	1117	642	77	1118	529	77	1119	416	77	-	-	-	-	-	-	-	-	-
	72	1030	883	76	1033	762	76	1034	654	76	1035	540	76	1034	424	76	-	-	-	-	-	-
	67	967	967	75	948	890	75	952	768	75	952	651	75	952	544	75	952	428	75	-	-	-
	62	966	966	75	922	922	74	878	878	74	872	774	74	874	659	74	874	544	74	874	428	74
	57	966	966	75	922	922	74	878	878	74	834	834	73	798	774	73	800	664	73	802	545	73
27,500	77	-	-	-	-	-	-	-	-	1151	438	78	-	-	-	-	-	-	-	-	-	-
	72	1059	981	76	1064	848	76	1065	706	76	1066	574	76	1066	442	77	-	-	-	-	-	-
	67	1029	1029	76	984	978	75	981	851	75	984	712	75	984	579	76	984	447	76	-	-	-
	62	1028	1028	76	981	981	75	934	934	74	902	858	74	905	717	74	904	587	74	904	447	75
	57	1028	1028	76	980	980	75	933	933	74	886	886	74	839	839	73	829	721	73	829	581	73
32,000	77	-	-	-	-	-	-	-	-	-	-	-	-	-	-	-	-	-	-	-	-	-
	72	1085	1072	76	1087	922	77	1088	763	77	1089	615	77	1090	458	77	-	-	-	-	-	-
	67	1079	1079	76	1029	1029	76	1002	928	75	1007	774	76	1007	619	76	1006	463	76	-	-	-
	62	1079	1079	76	1028	1028	76	979	979	75	930	925	75	927	778	75	928	619	75	927	464	75
	57	1079	1079	76	1028	1028	76	978	978	75	928	928	74	878	878	74	849	781	74	851	622	74

**Table 127: 80 ton high capacity - 105°F ambient air temperature**

CFM	EWB (°F)	95°F EDB			90°F EDB			85°F EDB			80°F EDB			75°F EDB			70°F EDB			65°F EDB		
		TMBH	SMBH	kW	TMBH	SMBH	kW	TMBH	SMBH	kW	TMBH	SMBH	kW	TMBH	SMBH	kW	TMBH	SMBH	kW	TMBH	SMBH	kW
14,000	77	950	578	83	952	497	83	953	429	83	953	358	83	-	-	-	-	-	-	-	-	-
	72	872	645	82	873	571	82	874	500	82	875	434	82	875	362	82	-	-	-	-	-	-
	67	797	719	80	798	646	80	800	574	80	800	506	80	800	432	81	801	364	81	-	-	-
	62	756	756	79	731	714	79	729	646	79	730	576	79	731	503	79	731	436	79	731	361	79
	57	758	758	79	724	724	79	690	690	78	-	-	-	-	-	-	-	-	-	-	-	-
18,500	77	1019	658	84	1020	577	84	1022	477	84	1022	378	84	-	-	-	-	-	-	-	-	-
	72	937	753	83	938	661	83	940	579	83	940	478	83	941	386	83	-	-	-	-	-	-
	67	860	851	81	860	758	82	862	667	82	863	575	82	864	481	82	863	389	82	-	-	-
	62	855	855	81	816	816	81	788	764	80	789	673	80	791	574	80	792	482	81	792	388	81
	57	855	855	81	816	816	81	777	777	80	738	738	79	722	671	79	723	578	79	724	478	79
23,000	77	1060	737	85	1061	626	85	1063	510	85	1064	404	85	-	-	-	-	-	-	-	-	-
	72	978	859	83	981	743	84	983	634	84	984	514	84	984	403	84	-	-	-	-	-	-
	67	930	930	82	900	862	82	902	754	82	904	637	83	905	518	83	904	407	83	-	-	-
	62	929	929	82	886	886	82	843	843	81	827	752	81	829	635	81	830	525	81	830	408	82
	57	928	928	82	886	886	82	843	843	81	801	801	80	759	759	80	759	638	80	761	525	80
27,500	77	-	-	-	-	-	-	-	-	-	-	-	-	-	-	-	-	-	-	-	-	-
	72	1003	959	84	1009	825	84	1011	690	84	1011	555	84	1012	419	85	-	-	-	-	-	-
	67	987	987	83	941	941	83	930	833	83	933	693	83	933	559	83	933	424	83	-	-	-
	62	986	986	83	941	941	83	895	895	82	855	836	82	858	700	82	857	575	82	858	428	82
	57	987	987	83	941	941	83	895	895	82	849	849	81	803	803	81	785	699	81	786	566	81
32,000	77	-	-	-	-	-	-	-	-	-	-	-	-	-	-	-	-	-	-	-	-	-
	72	1036	1033	84	1028	900	84	1032	744	85	1033	593	85	1033	434	85	-	-	-	-	-	-
	67	1034	1034	84	986	986	84	949	917	83	954	752	83	954	596	84	953	439	84	-	-	-
	62	1033	1033	84	985	985	83	936	936	83	887	887	82	875	760	82	879	601	82	878	445	83
	57	1033	1033	84	985	985	83	936	936	83	887	887	82	839	839	81	803	763	81	806	596	81

**Table 128: 80 ton high capacity - 115°F ambient air temperature**

CFM	EWB (°F)	95°F EDB			90°F EDB			85°F EDB			80°F EDB			75°F EDB			70°F EDB			65°F EDB		
		TMBH	SMBH	kW	TMBH	SMBH	kW	TMBH	SMBH	kW	TMBH	SMBH	kW	TMBH	SMBH	kW	TMBH	SMBH	kW	TMBH	SMBH	kW
14,000	77	902	554	91	904	480	91	904	412	91	905	338	91	-	-	-	-	-	-	-	-	-
	72	827	624	90	828	553	90	829	482	90	830	411	90	830	340	90	-	-	-	-	-	-
	67	756	701	88	757	625	88	758	557	89	760	484	89	760	415	89	760	342	89	-	-	-
	62	726	726	88	699	688	87	691	630	87	692	554	87	693	483	87	694	413	87	694	343	88
	57	726	726	88	695	695	87	663	663	86	633	626	86	634	558	86	634	482	86	635	413	86
18,500	77	963	640	93	965	546	93	966	453	93	967	358	93	-	-	-	-	-	-	-	-	-
	72	885	736	91	887	642	91	888	547	91	889	460	91	890	365	91	-	-	-	-	-	-
	67	822	818	90	812	740	90	814	646	90	816	551	90	817	457	90	817	368	90	-	-	-
	62	819	819	90	781	781	89	746	740	88	746	650	88	747	557	89	748	462	89	749	367	89
	57	819	819	90	781	781	89	743	743	88	706	706	88	682	648	87	683	553	87	684	458	87
23,000	77	-	-	-	-	-	-	1003	494	94	1003	381	94	-	-	-	-	-	-	-	-	-
	72	920	838	92	924	726	92	926	607	92	927	494	92	928	382	92	-	-	-	-	-	-
	67	889	889	91	850	842	90	850	730	90	852	617	91	853	497	91	854	385	91	-	-	-
	62	888	888	91	846	846	90	804	804	89	779	731	89	781	615	89	783	503	90	782	384	90
	57	888	888	91	846	846	90	804	804	89	763	763	89	722	722	88	715	622	88	717	502	88
27,500	77	-	-	-	-	-	-	-	-	-	-	-	-	-	-	-	-	-	-	-	-	-
	72	949	932	92	949	803	92	952	669	93	952	532	93	953	400	93	-	-	-	-	-	-
	67	942	942	92	897	897	91	874	814	91	878	674	91	879	535	92	879	404	92	-	-	-
	62	941	941	92	897	897	91	852	852	90	809	804	90	805	682	90	807	540	90	807	403	90
	57	941	941	92	897	897	91	852	852	90	807	807	90	764	764	89	737	686	89	739	539	89
32,000	77	-	-	-	-	-	-	-	-	-	-	-	-	-	-	-	-	-	-	-	-	-
	72	986	986	93	970	889	93	970	726	93	971	577	93	971	415	94	-	-	-	-	-	-
	67	985	985	93	939	939	92	895	885	91	896	733	92	898	579	92	896	419	92	-	-	-
	62	985	985	93	937	937	92	891	891	91	843	843	90	824	740	90	826	574	91	825	418	91
	57	984	984	93	937	937	92	891	891	91	843	843	90	797	797	90	754	739	89	757	575	89

**Table 129: 80 ton high capacity - 125°F ambient air temperature**

CFM	EWB (°F)	95°F EDB			90°F EDB			85°F EDB			80°F EDB			75°F EDB			70°F EDB			65°F EDB		
		TMBH	SMBH	kW	TMBH	SMBH	kW	TMBH	SMBH	kW	TMBH	SMBH	kW	TMBH	SMBH	kW	TMBH	SMBH	kW	TMBH	SMBH	kW
14,000	77	849	529	100	850	457	101	851	388	101	851	319	101	-	-	-	-	-	-	-	-	-
	72	778	603	99	779	533	99	780	462	99	781	392	99	782	320	99	-	-	-	-	-	-
	67	711	678	97	712	606	97	714	535	98	715	467	98	716	395	98	716	322	98	-	-	-
	62	694	694	97	663	661	96	651	606	96	652	538	96	653	466	96	653	393	96	653	320	97
	57	694	694	97	663	661	96	632	632	96	600	600	95	596	537	95	597	466	95	597	394	95
18,500	77	901	616	102	904	520	102	905	432	102	906	335	102	-	-	-	-	-	-	-	-	-
	72	828	713	100	830	624	100	833	528	100	834	432	101	835	342	101	-	-	-	-	-	-
	67	781	780	99	761	722	99	763	627	99	764	532	99	766	435	99	766	345	99	-	-	-
	62	780	780	99	743	743	98	708	704	97	698	630	97	700	535	97	702	440	98	702	344	98
	57	780	780	99	742	742	98	706	706	97	670	670	97	639	626	96	641	538	96	641	442	96
23,000	77	-	-	-	-	-	-	-	-	-	-	-	-	-	-	-	-	-	-	-	-	-
	72	859	822	101	862	706	101	865	585	101	868	471	101	868	357	102	-	-	-	-	-	-
	67	844	844	100	803	803	99	793	713	99	796	594	100	798	475	100	798	360	100	-	-	-
	62	843	843	100	803	803	99	762	762	99	729	710	98	730	596	98	731	479	99	732	366	99
	57	843	843	100	802	802	99	762	762	99	723	723	98	683	683	97	667	601	97	669	482	97
27,500	77	-	-	-	-	-	-	-	-	-	-	-	-	-	-	-	-	-	-	-	-	-
	72	893	893	101	882	786	101	888	646	102	889	509	102	889	377	102	-	-	-	-	-	-
	67	893	893	101	850	850	100	814	791	100	817	652	100	821	516	101	821	381	101	-	-	-
	62	892	892	101	849	849	100	806	806	100	763	763	99	750	662	99	753	519	99	753	380	99
	57	891	891	101	849	849	100	806	806	100	763	763	99	721	721	98	687	660	97	689	516	98
32,000	77	-	-	-	-	-	-	-	-	-	-	-	-	-	-	-	-	-	-	-	-	-
	72	-	-	-	897	864	102	903	703	102	905	547	102	906	390	103	-	-	-	-	-	-
	67	-	-	-	886	886	101	842	842	100	833	713	101	837	548	101	837	393	101	-	-	-
	62	-	-	-	886	886	101	841	841	100	796	796	100	766	719	99	770	556	100	769	398	100
	57	-	-	-	886	886	101	841	841	100	796	796	100	751	751	99	707	707	98	704	563	98

**Notes:**

Rated performance is at sea level. Cooling capacities are gross cooling capacities.

CFM = airflow, EWB = entering wet bulb air, EDB = entering dry bulb air, TMBH = total cooling capacity (MBH)

SMBH = sensible cooling capacity (MBH), kW = total input

## Staged and modulating gas heat data

**Table 130: Staged and modulating gas heat**

Staged and modulating gas heat					Staged gas heat	Modulating gas heat
Model	Gas input capacity (MBH)	Maximum output capacity (MBH)	Minimum airflow (CFM)	Gas connection size (in.)	Steps	Turndown
25 ton to 30 ton	250	203	5,000	0.75	2	10:1
	500	405	5,000	1.00	2	20:1
	750	608	5,000	1.00	4	30:1
40 ton to 50 ton	500	405	8,000	1.00	2	20:1
	750	608	8,000	1.00	4	30:1
	1,250	1,013	8,000	1.25	6	50:1
60 ton	500	405	12,000	1.00	2	10:1
	1000	810	12,000	1.25	4	20:1
	1,500	1,215	12,000	1.50	6	30:1
70 ton to 80 ton	500	405	14,000	1.00	2	10:1
	1,000	810	14,000	1.25	4	20:1
	1,500	1,215	14,000	1.50	6	30:1

**Note:**

- Minimum airflow (CFM) is based on maximum output capacity (MBH).
- For proper operation, the building supplied natural gas pressure must be 7 iwg to 14 iwg and liquid propane pressure must be 12 iwg to 14 iwg.
- Temperature rise can be calculated where temperature rise = (gas input capacity (Btu) x 0.81) / (CFM x 1.085).
- Maximum leaving air temperature cannot exceed 120.0°F

## Electric heat data

**Table 131: Electric heat performance data**

Model	Voltage	Size (kW)	Heat capacity (MBH)	Minimum airflow (CFM)	Maximum temp. rise (°F)*
<b>Low heat</b>					
25 ton to 30 ton	208/230	50	171	3,000	52
	460/575	60	205	6,000	31
40 ton to 50 ton	208/230	60	205	4,000	47
	460/575	80	273	6,000	42
60 ton to 80 ton	208/230	90	307	10,000	28
	460	120	410	12,000	31
	575	120	410	12,000	31
<b>High heat</b>					
25 ton to 30 ton	208/230	100	341	6,500	48
	460/575	120	410	8,500	44
40 ton to 50 ton	208/230	120	410	8,000	47
	460/575	160	546	12,500	40
60 ton to 80 ton	208/230	120	410	10,000	38
	460	200	683	12,000	52
	575	200	683	12,000	52

**Note:**

- \* Maximum temperature rise is based on unit operation at the minimum airflow (CFM).

## Hot water coil data

**Table 132: Hot water coil performance data - 25 ton to 30 ton (1 row, low heat option)**

GPM	Water pressure drop	CFM	Capacity (MBH) at entering water			
			140.0°F	160.0°F	180.0°F	200.0°F
10	0.8	5,000	107.8	137.8	167.9	198.3
		6,000	124.4	159.1	194.0	229.1
		8,000	135.7	173.7	211.9	250.3
		10,000	144.2	184.7	225.3	266.2
		12,000	150.9	193.3	235.9	278.8
20	2.9	5,000	125.7	160.2	194.9	229.8
		6,000	149.4	190.4	231.8	273.3
		8,000	166.5	212.3	258.4	304.8
		10,000	179.9	229.5	279.4	329.5
		12,000	190.7	243.4	296.3	349.5
30	6.4	5,000	132.9	169.2	205.7	242.3
		6,000	159.9	203.6	247.5	291.6
		8,000	179.7	228.9	278.3	328.0
		10,000	195.6	249.1	303.0	357.0
		12,000	208.6	265.8	323.2	380.9
40	11.1	5,000	136.9	174.1	211.6	249.2
		6,000	165.7	210.8	256.1	301.7
		8,000	187.1	238.2	289.4	340.9
		10,000	204.5	260.2	316.2	372.5
		12,000	218.8	278.5	338.4	398.7

**Table 133: Hot water coil performance data - 25 ton to 30 ton (2 rows, high heat option)**

GPM	Water pressure drop	CFM	Capacity (MBH) at entering water			
			140.0°F	160.0°F	180.0°F	200.0°F
30	1.4	5,000	173.9	221.6	269.3	317.3
		6,000	218.2	278.1	338.4	398.9
		8,000	251.3	320.5	390.2	460.2
		10,000	277.6	354.3	431.4	509.0
		12,000	299.1	381.9	465.1	548.8
40	2.4	5,000	179.9	228.9	278.1	327.4
		6,000	228.1	290.5	353.2	416.0
		8,000	265.0	337.6	410.6	483.9
		10,000	294.9	375.8	457.2	539.0
		12,000	319.5	407.4	495.7	584.5
60	5.3	5,000	186.2	236.7	287.4	338.1
		6,000	238.9	303.9	369.0	434.4
		8,000	280	356.3	433.0	509.8
		10,000	314	399.6	485.7	572.1
		12,000	342.5	436.0	530.0	624.3

**Table 134: Hot water coil performance data - 40 ton to 50 ton (1 row, low heat option)**

GPM	Water pressure drop	CFM	Capacity (MBH) at entering water			
			140.0°F	160.0°F	180.0°F	200.0°F
20	1.0	8,000	204.0	260.6	317.6	374.9
		12,000	235.1	300.5	366.3	432.5
		16,000	256.4	328.0	399.9	472.3
		20,000	272.6	348.8	425.4	502.5

**Table 134: Hot water coil performance data - 40 ton to 50 ton (1 row, low heat option)**

GPM	Water pressure drop	CFM	Capacity (MBH) at entering water			
			140.0°F	160.0°F	180.0°F	200.0°F
40	3.8	8,000	235.8	300.4	365.4	430.7
		12,000	279.2	355.8	432.8	510.3
		16,000	310.5	395.9	481.7	567.9
		20,000	335.2	427.4	520.1	613.3
60	8.5	8,000	248.6	316.3	384.5	452.9
		12,000	297.5	378.6	460.3	542.2
		16,000	333.5	424.6	516.2	608.2
		20,000	362.3	461.3	560.8	660.8

**Table 135: Hot water coil performance data - 40 ton to 50 ton (2 rows, high heat option)**

GPM	Water pressure drop	CFM	Capacity (MBH) at entering water			
			140.0°F	160.0°F	180.0°F	200.0°F
40	1.0	8,000	312.0	397.9	484.3	571.0
		12,000	381.9	487.6	594.0	700.9
		16,000	432.2	552.3	673.0	794.5
		20,000	471.1	602.3	734.1	866.8
60	2.1	8,000	332.3	423.2	514.4	605.9
		12,000	414.5	528.3	642.7	757.4
		16,000	475.9	606.8	738.4	870.7
		20,000	524.5	669.1	814.5	960.7

**Table 136: Hot water coil performance data - 60 ton to 80 ton (1 row, low heat option)**

GPM	Water pressure drop	FPS	CFM	Capacity (MBH) at entering water			
				140.0°F	160.0°F	180.0°F	200.0°F
25	2.4	2.1	12,000	304.7	389.1	474.0	559.3
			19,000	354.2	452.7	551.6	651.0
			26,000	386.5	494.2	602.4	711.0
			32,000	406.9	520.5	634.5	749.0
50	5.2	4.1	12,000	359.3	457.7	556.6	656.0
			19,000	432.1	550.7	669.8	789.6
			26,000	482.8	615.5	748.8	882.7
			32,000	516.2	658.2	800.9	944.2
80	9.8	6.6	12,000	384.6	489.3	594.7	700.4
			19,000	469.9	598.0	726.8	856.1
			26,000	530.9	675.8	821.4	967.7
			32,000	572.0	728.3	885.2	1042.8
90	12.3	7.4	12,000	389.6	495.6	602.3	709.3
			19,000	477.5	607.6	738.3	869.6
			26,000	540.8	688.3	836.3	985.1
			32,000	583.6	742.8	902.6	1063.1

**Table 137: Hot water coil performance data - 60 ton to 80 ton (2 rows, high heat option)**

GPM	Water pressure drop	FPS	CFM	Capacity (MBH) at entering water			
				140.0°F	160.0°F	180.0°F	200.0°F
50	3	2.1	12,000	457.3	583.1	709.5	836.3
			19,000	568.9	726.2	884.3	1043.2
			26,000	645.5	824.6	1004.4	1185.2
			32,000	694.9	888	1082	1276.9

**Table 137: Hot water coil performance data - 60 ton to 80 ton (2 rows, high heat option)**

GPM	Water pressure drop	FPS	CFM	Capacity (MBH) at entering water			
				140.0°F	160.0°F	180.0°F	200.0°F
90	5.4	3.7	12,000	502.2	639.1	776.3	914
			19,000	644.7	821	998.1	1175.8
			26,000	748.6	953.8	1159.9	1367
			32,000	818.5	1043.2	1268.8	1495.5
130	8	5.3	12,000	521.3	662.9	804.7	946.9
			19,000	678.3	862.9	1048.4	1234.1
			26,000	795.8	1012.8	1230.7	1449.4
			32,000	876.4	1115.5	1355.7	1596.8
160	12	6.6	12,000	529.7	673.3	817.2	961.4
			19,000	693.4	881.7	1070.8	1260.1
			26,000	817.3	1039.5	1262.7	1486.6
			32,000	903	1148.7	1395.4	1643.1

**Note:**

For Glycol solution performance access Selection Navigator.

## Steam coil data

**Table 138: Steam coil performance data - 25 ton to 30 ton (low heat option)**

CFM	Capacity (MBH) at steam pressure (PSI)			
	2	6	10	15
5,000	205.6	220.7	233.7	247.7
6,000	244.3	262.3	277.7	294.4
8,000	273.2	293.3	310.5	329.2
10,000	296.1	318.0	336.0	356.9
12,000	315.4	338.6	358.5	380.1

**Table 139: Steam coil performance data - 25 ton to 30 ton (high heat option)**

CFM	Capacity (MBH) at steam pressure (PSI)			
	2	6	10	15
5,000	303.0	325.3	344.5	365.2
6,000	361.0	387.6	410.4	435.1
8,000	401.7	431.4	456.7	484.1
10,000	432.5	464.4	491.7	521.2
12,000	457.1	490.8	519.6	550.8

**Table 140: Steam coil performance data - 40 ton to 50 ton (low heat option)**

CFM	Capacity (MBH) at steam pressure (PSI)			
	2	6	10	15
8,000	381.5	409.7	433.7	459.8
12,000	450.8	484.0	512.4	543.2
16,000	502.0	539.0	570.7	605.0
20,000	542.8	582.8	617.0	654.1

**Table 141: Steam coil performance data - 40 ton to 50 ton (high heat option)**

CFM	Capacity (MBH) at steam pressure (PSI)			
	2	6	10	15
8,000	563.6	605.2	640.7	679.2
12,000	665.1	714.1	756.0	801.5

**Table 141: Steam coil performance data - 40 ton to 50 ton (high heat option)**

CFM	Capacity (MBH) at steam pressure (PSI)			
	2	6	10	15
16,000	735.5	789.7	836.1	886.3
20,000	788.4	846.5	896.3	950.1

**Table 142: Steam coil performance data - 60 ton to 70 ton (low heat option)**

CFM	Capacity (MBH) at steam pressure (PSI)				
	2	4	6	10	15
12,000	538.1	558.1	576.7	609.6	645.0
17,000	607.9	631.5	652.2	689.3	729.4
22,000	657.1	680.7	704.1	744.0	787.1
26,000	685.9	710.2	734.2	775.4	820.3
28,000	697.1	721.9	746.2	787.9	833.5

**Table 143: Steam coil performance data - 80 ton (low heat option)**

CFM	Capacity (MBH) at steam pressure (PSI)				
	2	4	6	10	15
16,000	727.2	751.7	775.9	820.2	869.8
22,000	818.5	829.5	854.0	901.4	954.0
26,000	854.4	865.0	889.0	937.4	991.7
32,000	890.0	900.4	923.3	972.1	1028.1

**Table 144: Steam coil performance data - 60 ton to 80 ton (high heat option)**

CFM	Capacity (MBH) at steam pressure (PSI)				
	2	4	6	10	15
12,000	867.5	920.9	940.2	987.8	1044.6
17,000	1013.7	1317.4	1110.2	1131.2	1188.8
22,000	1182.0	1330.15	1478.3	1232.9	1282.2
32,000		—		1343.8	1365.4

## Airflow performance

### 25 ton to 50 ton component static pressure drops (iwg)

**Table 145: 25 ton to 50 ton component static pressure drops (iwg)**

Component		SCFM								
		5,000	6,000	8,000	10,000	12,000	14,000	16,000	18,000	20,000
25 ton	Evaporator coil — std. capacity, std. efficiency	0.13	0.18	0.28	0.41	0.55	—	—	—	—
	Evaporator coil — high capacity, std. efficiency and std. capacity, high efficiency	0.15	0.20	0.32	0.46	0.62	—	—	—	—
30 ton	Evaporator coil — std. capacity, std. efficiency	0.16	0.22	0.36	0.51	0.69	—	—	—	—
	Evaporator coil — high capacity, std. efficiency and std. capacity, high efficiency	0.18	0.24	0.38	0.55	0.74	—	—	—	—
40 ton	Evaporator coil — std. capacity, std. efficiency	—	—	0.22	0.30	0.40	0.51	0.63	0.77	0.92
	Evaporator coil — high capacity, std. efficiency and std. capacity, high efficiency	—	—	0.22	0.30	0.40	0.51	0.63	0.77	0.92
50 ton	Evaporator coil — std. capacity, std. efficiency	—	—	0.22	0.30	0.40	0.51	0.63	0.77	0.92
	Evaporator coil — high capacity, std. efficiency and std. capacity, high efficiency	—	—	0.25	0.35	0.47	0.61	0.76	0.92	1.10
25 ton to 30 ton hot gas reheat (HGRH) coil		0.13	0.17	0.27	0.38	0.51	—	—	—	—
40 ton to 50 ton HGRH coil		—	—	0.12	0.18	0.24	0.32	0.40	0.48	0.58

**Table 146: Return air opening — 25 ton to 50 ton component static pressure drops (iwg)**

Component		SCFM								
		5,000	6,000	8,000	10,000	12,000	14,000	16,000	18,000	20,000
25 ton to 30 ton	Bottom, top, front, sides	0.01	0.02	0.03	0.05	0.06	—	—	—	—
	Bottom with energy recovery wheel (ERW)	0.01	0.01	0.03	0.04	0.06	—	—	—	—
	Damper	0.14	0.14	0.14	0.15	0.15	—	—	—	—
40 ton to 50 ton	Bottom, top, front, sides	—	—	0.01	0.02	0.03	0.04	0.05	0.06	0.08
	Bottom with ERW	0.01	0.01	0.01	0.02	0.03	0.04	0.05	0.06	0.08
	Damper	—	—	0.10	0.11	0.12	0.13	0.15	0.17	0.19

**Table 147: Exhaust air opening — 25 ton to 50 ton component static pressure drops (iwg)**

Component		SCFM								
		5,000	6,000	8,000	10,000	12,000	14,000	16,000	18,000	20,000
25 ton to 30 ton hood and damper		0.21	0.24	0.29	0.35	0.41	—	—	—	—
40 ton to 50 ton hood and damper		—	—	0.22	0.26	0.29	0.33	0.37	0.41	0.45

**Table 148: Supply air opening — 25 ton to 50 ton component static pressure drops (iwg)**

Component		SCFM								
		5,000	6,000	8,000	10,000	12,000	14,000	16,000	18,000	20,000
25 ton to 30 ton	Bottom	0.01	0.01	0.02	0.03	0.04	—	—	—	—
	Side	0.01	0.01	0.02	0.03	0.04	—	—	—	—
	All discharges in blank section	0.02	0.02	0.04	0.06	0.09	—	—	—	—

**Table 148: Supply air opening — 25 ton to 50 ton component static pressure drops (iwg)**

Component		SCFM								
		5,000	6,000	8,000	10,000	12,000	14,000	16,000	18,000	20,000
40 ton to 50 ton	Bottom	—	—	0.01	0.02	0.03	0.04	0.05	0.06	0.08
	Side	—	—	0.01	0.02	0.03	0.04	0.05	0.06	0.08
	All discharges in blank section	—	—	0.02	0.03	0.04	0.06	0.08	0.10	0.12

**Table 149: Outside air — 25 ton to 50 ton component static pressure drops (iwg)**

Component		SCFM								
		5,000	6,000	8,000	10,000	12,000	14,000	16,000	18,000	20,000
25 ton to 30 ton	Hood and dampers — low leak	0.26	0.31	0.42	0.54	0.68	—	—	—	—
	Hood and dampers — ultra low leak	0.25	0.30	0.41	0.53	0.67	—	—	—	—
40 ton to 50 ton	Hood and dampers — low leak	—	—	0.28	0.35	0.43	0.52	0.61	0.71	0.82
	Hood and dampers — ultra low leak	—	—	0.27	0.34	0.42	0.50	0.59	0.69	0.79

**Table 150: ERW — low CFM — 25 ton to 50 ton component static pressure drops (iwg)**

Component		SCFM								
		5,000	6,000	8,000	10,000	12,000	14,000	16,000	18,000	20,000
25 ton to 30 ton		1.14	1.38	1.89	2.44	3.01	—	—	—	—
40 ton to 50 ton		—	—	0.89	1.13	1.37	1.63	1.89	2.15	2.43

**Table 151: ERW — high CFM — 25 ton to 50 ton component static pressure drops (iwg)**

Component		SCFM								
		5,000	6,000	8,000	10,000	12,000	14,000	16,000	18,000	20,000
25 ton to 30 ton		1.09	1.31	1.77	2.24	2.73	—	—	—	—
40 ton to 50 ton		—	—	0.89	1.11	1.34	1.57	1.80	2.04	2.29

**Table 152: Draw—through filters — 25 ton to 50 ton component static pressure drops (iwg)**

Component		SCFM								
		5,000	6,000	8,000	10,000	12,000	14,000	16,000	18,000	20,000
25 ton to 30 ton	Angled filter rack — 2 in. throwaway filters	0.04	0.05	0.09	0.11	0.13	—	—	—	—
	Angled filter rack — 2 in. MERV 8 filters	0.05	0.06	0.08	0.11	0.14	—	—	—	—
	Rigid filter rack — MERV 15 bag filters with 2 in. MERV 8 pre—filters	0.44	0.52	0.69	0.85	1.01	—	—	—	—
	Rigid filter rack — MERV 14 rigid filters with 2 in. MERV 8 pre—filters	0.20	0.24	0.33	0.43	0.53	—	—	—	—
	Vertical filter rack — 4 in. MERV 8 filters	0.03	0.04	0.06	0.09	0.12	—	—	—	—

**Table 152: Draw—through filters — 25 ton to 50 ton component static pressure drops (iwg)**

Component		SCFM								
		5,000	6,000	8,000	10,000	12,000	14,000	16,000	18,000	20,000
40 ton to 50 ton	Angled filter rack — 2 in. throwaway filters	—	—	0.06	0.08	0.09	0.11	0.13	0.15	0.17
	Angled filter rack — 2 in. MERV 8 filters	—	—	0.06	0.08	0.10	0.12	0.15	0.18	0.21
	Rigid filter rack — MERV 15 bag filters with 2 in. MERV 8 pre—filters	—	—	0.33	0.43	0.53	0.64	0.76	0.88	1.02
	Rigid filter rack — MERV 14 rigid filters with 2 in. MERV 8 pre—filters	—	—	0.23	0.30	0.37	0.44	0.52	0.60	0.68
	Vertical filter rack — 4 in. MERV 8 filters	—	—	0.04	0.05	0.07	0.09	0.12	0.15	0.18

**Table 153: Final filters — 25 ton to 50 ton component static pressure drops (iwg)**

Component		SCFM								
		5,000	6,000	8,000	10,000	12,000	14,000	16,000	18,000	20,000
25 ton to 30 ton	MERV 14 Rigid Final Filters With 2 in. Pre Filters	0.21	0.26	0.36	0.47	0.59	—	—	—	—
	MERV 15 Bag Final Filters With 2 in. Pre Filters	0.44	0.53	0.70	0.87	1.03	—	—	—	—
	MERV 17 HEPA Final Filters With 2 in. Pre Filters	0.60	0.72	0.96	1.20	1.45	—	—	—	—
40 ton to 50 ton	MERV 14 Rigid Final Filters With 2 in. pre—filters	—	—	0.25	0.32	0.39	0.47	0.55	0.64	0.73
	MERV 15 Bag Final Filters With 2 in. pre—filters	—	—	0.52	0.64	0.75	0.87	0.98	1.08	1.19
	MERV 17 HEPA Final Filters With 2 in. pre—filters	—	—	0.76	0.94	1.13	1.32	1.51	1.71	1.90

**Table 154: Gas heat — 25 ton to 50 ton component static pressure drops (iwg)**

Component	SCFM								
	5,000	6,000	8,000	10,000	12,000	14,000	16,000	18,000	20,000
250 MBH	0.00	0.00	0.01	0.02	0.04	—	—	—	—
500 MBH	0.00	0.00	0.01	0.03	0.05	0.07	0.10	0.14	0.18
750 MBH	0.02	0.02	0.03	0.05	0.07	0.10	0.14	0.19	0.25
1250 MBH	—	0.03	0.04	0.06	0.08	0.11	0.15	0.20	0.26

**Table 155: Electric heat — 25 ton to 50 ton component static pressure drops (iwg)**

Component	SCFM								
	5,000	6,000	8,000	10,000	12,000	14,000	16,000	18,000	20,000
Low and high heat	0.18	0.21	0.27	0.34	0.40	0.46	0.52	0.59	0.65

**Table 156: Hot water and steam coil heat — 25 ton to 50 ton component static pressure drops (iwg)**

Component		SCFM								
		5,000	6,000	8,000	10,000	12,000	14,000	16,000	18,000	20,000
25 ton to 30 ton	1 row hot water, low heat	0.04	0.06	0.1	0.15	0.21	—	—	—	—
	2 rows hot water, high heat	0.07	0.10	0.16	0.24	0.32	—	—	—	—
	Steam, low heat	0.10	0.13	0.20	0.30	0.42	—	—	—	—
	Steam, high heat	0.11	0.15	0.25	0.36	0.49	—	—	—	—

**Table 156: Hot water and steam coil heat — 25 ton to 50 ton component static pressure drops (iwg)**

Component		SCFM								
		5,000	6,000	8,000	10,000	12,000	14,000	16,000	18,000	20,000
40 ton to 50 ton	1 row hot water, low heat	—	—	0.05	0.07	0.09	0.12	0.15	0.19	0.24
	2 rows hot water, high heat	—	—	0.08	0.12	0.16	0.21	0.27	0.33	0.40
	Steam, low heat	—	—	0.07	0.10	0.13	0.17	0.21	0.26	0.30
	Steam, high heat	—	—	0.10	0.15	0.20	0.26	0.33	0.41	0.49

**Table 157: Options — 25 ton to 50 ton component static pressure drops (iwg)**

Component		SCFM								
		5,000	6,000	8,000	10,000	12,000	14,000	16,000	18,000	20,000
Humidifier		0.01	0.01	0.01	0.01	0.01	0.01	0.01	0.01	0.02
25 ton to 30 ton	Sound attenuator	0.01	0.01	0.02	0.03	0.04	—	—	—	—
	Inlet guard — supply fan	0.08	0.11	0.19	0.30	0.43	—	—	—	—
	Air blender	0.08	0.11	0.19	0.30	0.43	—	—	—	—
40 ton to 50 ton	Sound attenuator	—	—	0.01	0.02	0.03	0.04	0.05	0.06	0.08
	Inlet guard — supply fan	—	—	0.13	0.20	0.28	0.39	0.51	0.64	0.79
	Air blender	—	—	0.13	0.20	0.29	0.39	0.51	0.65	0.80

## 60 ton to 80 ton component static pressure drops (iwg)

**Table 158: 60 ton to 80 ton component static pressure drops (iwg)**

Component		SCFM									
		12,000	14,000	16,000	18,000	20,000	24,000	26,000	28,000	30,000	32,000
60 ton	Evaporator coil—standard capacity, standard efficiency	0.29	0.37	0.45	0.53	0.61	0.81	—	—	—	—
	Evaporator coil—high capacity, standard capacity, high efficiency	0.39	0.49	0.60	0.71	0.82	1.06	—	—	—	—
70 ton	Evaporator coil—standard capacity, standard efficiency	—	0.31	0.43	0.56	0.70	0.98	1.13	1.29	1.45	1.62
	Evaporator coil—high capacity, standard capacity, high efficiency	—	0.34	0.47	0.61	0.76	1.07	1.23	1.40	1.58	1.77
80 ton	Evaporator coil—standard capacity, standard efficiency	—	0.34	0.47	0.61	0.76	1.07	1.23	1.40	1.58	1.77
	Evaporator coil—high capacity, standard capacity, high efficiency	—	0.34	0.47	0.61	0.76	1.07	1.23	1.40	1.58	1.77
60 ton hot gas reheat (HGRH) coil		0.08	0.10	0.13	0.15	0.17	0.22	—	—	—	—
70 ton to 80 ton HGRH coil		—	0.07	0.09	0.11	0.13	0.18	0.20	0.22	0.25	0.27

**Table 159: Return air opening—60 ton to 80 ton component static pressure drops (iwg)**

Component		SCFM									
		12,000	14,000	16,000	18,000	20,000	24,000	26,000	28,000	30,000	32,000
60 ton	Bottom return basic econ and barometric econ	0.07	0.07	0.08	0.09	0.10	0.11	—			
	Bottom return exhaust fan	0.07	0.07	0.07	0.08	0.09	0.10				
	Bottom return return fan	0.11	0.13	0.15	0.18	0.21	0.28				
	Damper	0.01	0.01	0.01	0.02	0.02	0.03				
	Left and right return—basic econ and barometric econ	0.07	0.08	0.08	0.09	0.10	0.12				
	Front return—basic econ—basic econ and barometric econ	0.07	0.07	0.07	0.08	0.08	0.10				
	Top return—basic econ—basic econ and barometric econ	0.07	0.07	0.08	0.09	0.10	0.12				
	Left and right return—exhaust fan	0.06	0.07	0.07	0.07	0.08	0.08				
	Front return—basic econ—exhaust fan	0.07	0.07	0.07	0.08	0.08	0.10				
	Top return—basic econ—exhaust fan	0.07	0.07	0.07	0.08	0.09	0.10				
	Left, right, front return—return fan	0.11	0.13	0.15	0.18	0.21	0.28				
	Bottom return—ERW	0.08	0.08	0.09	0.10	0.11	0.14				
70 ton to 80 ton	Bottom return basic econ and barometric econ	—	0.07	0.08	0.09	0.10	0.11	0.13	0.14	0.15	0.17
	Bottom return exhaust fan	—	0.07	0.07	0.08	0.09	0.10	0.11	0.12	0.13	0.14
	Bottom return return fan	—	0.13	0.15	0.18	0.21	0.28	0.32	0.37	0.42	0.47
	Damper	—	0.01	0.01	0.01	0.02	0.02	0.03	0.03	0.04	0.04
	Left and right return—basic econ and barometric econ	—	0.08	0.08	0.09	0.10	0.12	0.13	0.15	0.16	0.18
	Front return—basic econ—basic econ and barometric econ	—	0.07	0.07	0.08	0.08	0.10	0.11	0.11	0.12	0.13
	Top return—basic econ—basic econ and barometric econ	—	0.07	0.08	0.09	0.10	0.12	0.13	0.14	0.15	0.17
	Left and right return—exhaust fan	—	0.07	0.07	0.07	0.08	0.08	0.09	0.10	0.10	0.11
	Front return—basic econ—exhaust fan	—	0.07	0.07	0.08	0.08	0.10	0.11	0.11	0.12	0.13
	Top return—basic econ—exhaust fan	—	0.07	0.07	0.08	0.09	0.10	0.11	0.12	0.13	0.14
	Left, right, front return—return fan	—	0.11	0.12	0.14	0.17	0.22	0.25	0.28	0.32	0.36
	Bottom return—ERW	—	0.07	0.08	0.08	0.09	0.10	0.11	0.12	0.13	0.14

**Table 160: Exhaust air opening—60 ton to 80 ton component static pressure drops (iwg)**

Component		SCFM									
		12,000	14,000	16,000	18,000	20,000	24,000	26,000	28,000	30,000	32,000
60 ton	Barometric Econ Hood and Damper	0.17	0.22	0.29	0.37	0.47	0.69	—	—	—	—
	Econ with Exhaust Fan - Hood and Backdraft Damper	0.26	0.30	0.35	0.40	0.47	0.62	—	—	—	—
	Econ with Exhaust Fan - Hood and Modulating Damper	0.06	0.08	0.10	0.13	0.16	0.23	—	—	—	—
	Econ with Return Fan - Hood and Modulating Damper	0.04	0.06	0.08	0.10	0.12	0.17	—	—	—	—
	Barometric Econ Damper	0.14	0.18	0.23	0.29	0.37	0.55	—	—	—	—
	Econ with Exhaust Fan Backdraft Damper	0.02	0.03	0.04	0.05	0.07	0.09	—	—	—	—
	Econ with Exhaust Fan Modulating Damper	0.22	0.25	0.29	0.33	0.37	0.48	—	—	—	—
	Econ with Return Fan Modulating Damper	0.01	0.01	0.01	0.02	0.02	0.03	—	—	—	—
	Econ with Fan - Hood	0.04	0.05	0.06	0.08	0.10	0.14	—	—	—	—
	Econ with ERW Fan - Hood	0.07	0.10	0.12	0.16	0.20	0.28	—	—	—	—
	Econ With ERW - Hood and Backdraft Damper	0.32	0.39	0.47	0.56	0.66	0.89	1.03	—	—	—
70 ton to 80 ton	Barometric Econ Hood and Damper	xxx	0.04	0.05	0.06	0.08	0.11	0.13	0.15	0.17	0.19
	Econ with Exhaust Fan - Hood and Backdraft Damper	—	0.28	0.33	0.38	0.43	0.56	0.64	0.72	0.81	0.91
	Econ with Exhaust Fan - Hood and Modulating Damper	—	0.06	0.08	0.10	0.13	0.18	0.22	0.25	0.29	0.33
	Econ with Return Fan - Hood and Modulating Damper	—	0.04	0.05	0.06	0.08	0.11	0.13	0.15	0.2	0.19
	Barometric Econ Damper	—	0.01	0.01	0.01	0.01	0.02	0.02	0.03	0.03	0.03
	Econ with Exhaust Fan Backdraft Damper	—	0.03	0.04	0.05	0.07	0.09	0.11	0.13	0.15	0.17
	Econ with Exhaust Fan Modulating Damper	—	0.25	0.29	0.33	0.37	0.48	0.54	0.60	0.67	0.75
	Econ with Return Fan Modulating Damper	—	0.01	0.01	0.01	0.01	0.02	0.02	0.03	0.03	0.03
	Econ with Fan - Hood	—	0.03	0.04	0.05	0.06	0.09	0.11	0.12	0.14	0.16
	Econ with ERW Fan - Hood	—	0.06	0.08	0.10	0.12	0.18	0.21	0.24	0.28	0.32
	Econ With ERW - Hood and Backdraft Damper	—	0.31	0.37	0.43	0.50	0.65	0.75	0.85	0.95	1.07

**Table 161: Supply air opening—60 ton to 80 ton component static pressure drops (iwg)**

Component		SCFM									
		12,000	14,000	16,000	18,000	20,000	24,000	26,000	28,000	30,000	32,000
60 ton	Discharge from blank section (left and right)	0.05	0.07	0.09	0.11	0.13	0.19	—	—	—	—
	Discharge from blank section (top and bottom)	0.04	0.06	0.07	0.09	0.11	0.16	—	—	—	—
	Discharge from heating section (bottom and left)	0.04	0.05	0.06	0.08	0.10	0.14	—	—	—	—

**Table 161: Supply air opening—60 ton to 80 ton component static pressure drops (iwg)**

Component		SCFM									
		12,000	14,000	16,000	18,000	20,000	24,000	26,000	28,000	30,000	32,000
70 ton to 80 ton	Discharge from blank section (left and right)	—	0.04	0.05	0.06	0.07	0.11	0.12	0.14	0.16	0.18
	Discharge from blank section (top and bottom)	—	0.03	0.04	0.05	0.07	0.09	0.11	0.12	0.14	0.16
	Discharge from heating section (bottom and left)	—	0.05	0.06	0.08	0.10	0.14	0.16	0.19	0.21	0.24

**Table 162: Outside air—60 ton to 80 ton component static pressure drops (iwg)**

Component		SCFM									
		12,000	14,000	16,000	18,000	20,000	24,000	26,000	28,000	30,000	32,000
60 ton	Barometric Econ - Hood and Dampers - Low Leak	0.14	0.18	0.22	0.27	0.32	0.44	—	—	—	—
	Barometric Econ - Hood and Dampers - Ultra Low Leak	0.14	0.18	0.22	0.26	0.32	0.43	—	—	—	—
	Econ with Fan- Hood and Dampers - Low Leak	0.10	0.12	0.15	0.17	0.20	0.27	—	—	—	—
	Econ with Fan - Hood and Dampers - Ultra Low Leak	0.10	0.12	0.14	0.17	0.20	0.27	—	—	—	—
	Barometric Econ - Mist and Damper - Low Leak	0.09	0.10	0.12	0.14	0.17	0.22	—	—	—	—
	Barometric Econ - Mist and Damper - Ultra Low Leak	0.09	0.10	0.12	0.14	0.16	0.22	—	—	—	—
	Econ with Fan- Mist and Dampers - Low Leak	0.07	0.08	0.09	0.11	0.12	0.16	—	—	—	—
	Econ with Fan - Mist and Dampers - Ultra Low Leak	0.07	0.08	0.09	0.10	0.12	0.15	—	—	—	—
	Barometric Econ - Hood	0.05	0.07	0.10	0.12	0.15	0.22	—	—	—	—
	Econ with Fan - Hood	0.03	0.04	0.05	0.07	0.08	0.12	—	—	—	—
70 ton to 80 ton	Barometric Econ - Hood and Dampers - Low Leak	—	0.17	0.21	0.26	0.31	0.43	0.49	0.57	0.64	0.72
	Barometric Econ - Hood and Dampers - Ultra Low Leak	—	0.17	0.21	0.26	0.31	0.43	0.49	0.56	0.64	0.72
	Econ with Fan- Hood and Dampers - Low Leak	—	0.12	0.14	0.17	0.20	0.26	0.30	0.34	0.39	0.43
	Econ with Fan - Hood and Dampers - Ultra Low Leak	—	0.12	0.14	0.17	0.19	0.26	0.30	0.34	0.38	0.43
	Barometric Econ - Mist and Damper - Low Leak	—	0.10	0.12	0.14	0.16	0.21	0.24	0.27	0.30	0.33
	Barometric Econ - Mist and Damper - Ultra Low Leak	—	0.10	0.12	0.14	0.16	0.21	0.23	0.26	0.30	0.33
	Econ with Fan- Mist and Dampers - Low Leak	—	0.08	0.09	0.10	0.11	0.15	0.16	0.18	0.20	0.22
	Econ with Fan - Mist and Dampers - Ultra Low Leak	—	0.08	0.09	0.10	0.11	0.14	0.16	0.18	0.20	0.22
	Barometric Econ - Hood	—	0.07	0.10	0.12	0.15	0.22	0.26	0.30	0.34	0.39
	Econ with Fan - Hood	—	0.04	0.05	0.07	0.08	0.12	0.14	0.16	0.18	0.21

**Table 163: ERW—low CFM—60 ton to 80 ton component static pressure drops (iwg)**

Component		SCFM									
		12,000	14,000	16,000	18,000	20,000	24,000	26,000	28,000	30,000	32,000
60 ton	ERW and filter OA	1.40	1.66	1.94	2.22	2.51	3.11	—	—	—	—
	ERW and filter RA	1.35	1.62	1.89	2.17	2.45	3.05	—	—	—	—
	Bypass damper (OA or RA)	0.17	0.19	0.21	0.23	0.25	0.29	—	—	—	—
70 ton to 80 ton	ERW and filter OA	1.22	1.46	1.69	1.94	2.19	2.71	2.98	3.25	3.53	3.82
	ERW and filter RA	1.19	1.41	1.65	1.89	2.13	2.64	2.90	3.17	3.44	3.72
	Bypass damper (OA or RA)	0.12	0.14	0.17	0.20	0.23	0.30	0.33	0.37	0.42	0.46

**Table 164: ERW—high CFM—60 ton to 80 ton component static pressure drops (iwg)**

Component		SCFM									
		12,000	14,000	16,000	18,000	20,000	24,000	26,000	28,000	30,000	32,000
60 ton	ERW and filter OA	1.07	1.27	1.48	1.70	1.92	2.39	—	—	—	—
	ERW and filter RA	1.03	1.23	1.44	1.66	1.88	2.35	—	—	—	—
	Bypass damper (OA or RA)	0.21	0.24	0.28	0.31	0.35	0.44	—	—	—	—
70 ton to 80 ton	ERW and filter OA	1.05	1.24	1.44	1.64	1.84	2.27	2.49	2.72	2.95	3.19
	ERW and filter RA	1.01	1.20	1.40	1.59	1.80	2.22	2.44	2.67	2.90	3.14
	Bypass damper (OA or RA)	0.13	0.16	0.19	0.22	0.26	0.35	0.39	0.44	0.50	0.55

**Table 165: Draw-through filters—60 ton to 80 ton component static pressure drops (iwg)**

Component		SCFM									
		12,000	14,000	16,000	18,000	20,000	24,000	26,000	28,000	30,000	32,000
60 ton	2 in. throwaway angled filters	0.06	0.08	0.09	0.10	0.11	0.14	—	—	—	—
	2 in. MERV 8 angled filters	0.06	0.08	0.09	0.11	0.13	0.17	—	—	—	—
	MERV 15 bag filters with 2 in. MERV 8 pre—filters	0.52	0.60	0.67	0.75	0.83	0.98	—	—	—	—
	MERV 14 rigid filters with 2 in. MERV 8 pre—filters	0.26	0.32	0.37	0.43	0.49	0.61	—	—	—	—
	Vertical 4 in. MERV 8 filters	0.04	0.05	0.07	0.08	0.10	0.14	—	—	—	—
70 ton to 80 ton	2 in. throwaway angled filters	—	0.08	0.09	0.10	0.11	0.14	0.15	0.17	0.18	0.20
	2 in. MERV 8 angled filters	—	0.08	0.09	0.11	0.13	0.17	0.19	0.21	0.23	0.25
	MERV 15 bag filters with 2 in. MERV 8 pre—filters	—	0.60	0.67	0.75	0.83	0.98	1.06	1.13	1.20	1.28
	MERV 14 rigid filters with 2 in. MERV 8 pre—filters	—	0.32	0.37	0.43	0.49	0.61	0.67	0.74	0.80	0.86
	Vertical 4 in. MERV 8 filters	—	0.05	0.07	0.08	0.10	0.14	0.16	0.18	0.20	0.23

**Table 166: Final filters—60 ton to 80 ton component static pressure drops (iwg)**

Component		SCFM									
		12,000	14,000	16,000	18,000	20,000	24,000	26,000	28,000	30,000	32,000
60 ton	MERV 15 bag filters with 2 in. pre—filters	0.52	0.60	0.67	0.75	0.83	0.98	—	—	—	—
	MERV 14 rigid filters with 2 in. pre—filters	0.26	0.32	0.37	0.43	0.49	0.61	—	—	—	—
	MERV 17 HEPA filters with 2 in. pre—filters	0.34	0.36	0.39	0.42	0.45	0.51	—	—	—	—

**Table 166: Final filters—60 ton to 80 ton component static pressure drops (iwg)**

Component		SCFM									
		12,000	14,000	16,000	18,000	20,000	24,000	26,000	28,000	30,000	32,000
70 ton to 80 ton	MERV 15 bag filters with 2 in. pre—filters	—	0.60	0.67	0.75	0.83	0.98	1.06	1.13	1.20	1.28
	MERV 14 rigid filters with 2 in. pre—filters	—	0.32	0.37	0.43	0.49	0.61	0.67	0.74	0.80	0.86
	MERV 17 HEPA filters with 2 in. pre—filters	—	0.36	0.39	0.42	0.45	0.51	0.55	0.58	0.62	0.66

**Table 167: Gas heat—60 ton to 80 ton component static pressure drops (iwg)**

Component		SCFM									
		12,000	14,000	16,000	18,000	20,000	24,000	26,000	28,000	30,000	32,000
60 ton to 80 ton	500 MBH	—	0.07	0.10	0.14	0.18	0.27	0.33	0.38	0.45	0.52
	1000 MBH	0.08	0.14	0.19	0.25	0.30	0.38	0.42	0.46	0.50	0.53
	1500 MBH	0.17	0.21	0.26	0.32	0.39	0.59	0.71	0.84	0.98	1.14

**Table 168: Electric heat—60 ton to 80 ton component static pressure drops (iwg)**

Component		SCFM									
		12,000	14,000	16,000	18,000	20,000	24,000	26,000	28,000	30,000	32,000
60 ton to 80 ton	Low and high heat	0.03	0.03	0.03	0.03	0.03	0.04	0.04	0.04	0.04	0.04

**Table 169: Hot water and steam coil heat—60 ton to 80 ton component static pressure drops (iwg)**

Component		SCFM									
		12,000	14,000	16,000	18,000	20,000	24,000	26,000	28,000	30,000	32,000
60 ton	1 row hot water, low heat	0.05	0.07	0.08	0.1	0.12	0.16	—	—	—	—
	2 rows hot water, high heat	0.08	0.11	0.13	0.16	0.19	0.26	—	—	—	—
	Steam, low heat	0.04	0.05	0.07	0.08	0.1	0.14	—	—	—	—
	Steam, high heat	0.08	0.1	0.12	0.14	0.17	0.23	—	—	—	—
70 ton	1 row hot water, low heat	—	0.07	0.08	0.1	0.12	0.16	0.18	0.2	—	—
	2 rows hot water, high heat	—	0.11	0.13	0.16	0.19	0.26	0.3	0.34	—	—
	Steam, low heat	—	0.05	0.07	0.08	0.1	0.14	0.16	0.18	—	—
	Steam, high heat	—	0.1	0.12	0.14	0.17	0.23	0.26	0.29	—	—
80 ton	1 row hot water, low heat	—	—	0.08	0.1	0.12	0.16	0.18	0.2	0.23	0.25
	2 rows hot water, high heat	—	—	0.13	0.16	0.19	0.26	0.3	0.34	0.38	0.43
	Steam, low heat	—	—	0.09	0.1	0.13	0.17	0.2	0.23	0.26	0.29
	Steam, high heat	—	—	0.12	0.14	0.17	0.23	0.26	0.29	0.32	0.36

**Table 170: Options—60 ton to 80 ton component static pressure drops (iwg)**

Component		SCFM									
		12,000	14,000	16,000	18,000	20,000	24,000	26,000	28,000	30,000	32,000
60 ton	Humidifier	0.00	0.00	0.01	0.01	—	—	—	—	—	—
	Sound attenuator	0.01	0.02	0.02	0.03	0.04	0.05	0.06	0.07	0.08	0.09
	Inlet guard—supply fan	0.25	0.34	0.43	0.53	0.65	0.91	—	—	—	—
	Air blender	0.02	0.05	0.08	0.1	0.13	0.18	—	—	—	—
70 ton to 80 ton	Humidifier	—	0.01	0.01	0.01	0.01	0.01	0.01	0.01	0.02	0.02
	Sound attenuator	0.01	0.02	0.02	0.03	0.04	0.05	0.06	0.07	0.08	0.09
	Inlet guard—supply fan	—	0.34	0.43	0.53	0.65	0.91	1.05	1.21	1.38	1.56
	Air blender	—	0.03	0.05	0.07	0.09	0.14	0.16	0.19	0.21	0.23

# Supply fan data

**Table 171: 25 ton to 30 ton total static pressure**

CFM	1.0 TSP		1.5 TSP		2.0 TSP		2.5 TSP		3.0 TSP		3.5 TSP		4.0 TSP		4.5 TSP	
	RPM	BHP	RPM	BHP	RPM	BHP	RPM	BHP	RPM	BHP	RPM	BHP	RPM	BHP	RPM	BHP
5,000	746	1.12	855	1.68	964	2.30	1068	3.05	1165	3.79	1256	4.58	—	—	—	—
6,000	816	1.41	906	2.01	997	2.68	1088	3.36	1178	4.18	1265	5.09	1348	5.99	1426	6.88
7,000	894	1.74	974	2.44	1051	3.14	1129	3.89	1207	4.70	1285	5.51	1362	6.46	1437	7.51
8,000	978	2.11	1049	2.90	1119	3.70	1186	4.51	1254	5.32	1322	6.24	1390	7.16	1458	8.08
9,000	1068	2.58	1130	3.41	1193	4.32	1255	5.21	1315	6.12	1375	7.02	1435	7.98	1495	9.04
10,000	1161	3.14	1216	4.01	1272	4.98	1329	5.99	1385	6.98	1439	7.99	1493	8.99	1547	9.99
11,000	1256	3.82	1306	4.71	1356	5.72	1407	6.80	1459	7.92	1511	9.00	1560	10.11	1609	11.22
12,000	1352	4.61	1398	5.55	1444	6.57	1491	7.70	1538	8.89	1585	10.11	1633	11.29	1678	12.49

**Table 172: 25 ton to 30 ton total static pressure**

CFM	5.0 TSP		5.5 TSP		6.0 TSP		6.5 TSP		7.0 TSP		7.5 TSP		8.0 TSP	
	RPM	BHP	RPM	BHP	RPM	BHP	RPM	BHP	RPM	BHP	RPM	BHP	RPM	BHP
5,000	—	—	—	—	—	—	—	—	—	—	—	—	—	—
6,000	1501	7.83	1574	8.84	—	—	—	—	—	—	—	—	—	—
7,000	1510	8.58	1580	9.62	1647	10.67	1712	11.75	1776	12.88	1838	14.07	—	—
8,000	1526	9.14	1593	10.30	1659	11.52	1722	12.73	1783	13.92	1843	15.11	1901	16.32
9,000	1556	10.06	1617	11.09	1678	12.20	1738	13.45	1797	14.77	1855	16.14	1912	17.51
10,000	1601	11.09	1656	12.27	1710	13.41	1765	14.54	1820	15.71	1874	16.99	1928	18.37
11,000	1658	12.31	1707	13.43	1756	14.63	1806	15.92	1855	17.21	1905	18.45	1955	19.69
12,000	1723	13.70	1768	14.91	1813	16.10	1858	17.32	1903	18.62	1949	20.00	1994	21.42

**Table 173: 40 ton to 50 ton total static pressure**

CFM	1.0 TSP		1.5 TSP		2.0 TSP		2.5 TSP		3.0 TSP		3.5 TSP		4.0 TSP		4.5 TSP	
	RPM	BHP	RPM	BHP	RPM	BHP	RPM	BHP	RPM	BHP	RPM	BHP	RPM	BHP	RPM	BHP
8,000	—	—	—	—	778	4.03	866	—	—	—	—	—	—	—	—	—
9,000	—	—	—	—	787	4.42	870	5.65	949	6.96	1021	8.34	—	—	—	—
10,000	—	—	—	—	803	4.84	879	6.14	954	7.51	1026	8.96	1095	10.44	1160	12.01
11,000	—	—	758	4.04	826	5.31	894	6.67	963	8.10	1032	9.60	1099	11.16	1162	12.77
12,000	—	—	791	4.49	854	5.82	916	7.24	978	8.73	1042	10.29	1105	11.92	1167	13.59
13,000	762	3.65	826	4.99	885	6.39	942	7.86	1000	9.41	1058	11.03	1116	12.72	1175	14.46
14,000	800	4.11	862	5.53	918	7.00	972	8.54	1025	10.15	1079	11.83	1132	13.57	1187	15.37
15,000	838	4.60	899	6.12	953	7.67	1005	9.28	1055	10.95	1104	12.68	1154	14.48	1204	16.34
16,000	877	5.15	936	6.76	989	8.39	1039	10.07	1086	11.80	1133	13.60	1180	15.46	1226	17.37
17,000	917	5.74	974	7.44	1026	9.16	1074	10.92	1120	12.72	1164	14.58	1208	16.50	1252	18.48
18,000	956	6.38	1013	8.17	1063	9.99	1110	11.83	1154	13.71	1197	15.64	1239	17.62	1281	19.65
19,000	997	7.08	1051	8.96	1101	10.87	1147	12.80	1190	14.76	1231	16.76	1272	18.80	1311	20.90
20,000	1038	7.84	1090	9.80	1139	11.81	1184	13.83	1226	15.87	1267	17.95	1306	20.07	1344	22.23

**Table 174: 40 ton to 50 ton total static pressure**

CFM	5.0 TSP		5.5 TSP		6.0 TSP		6.5 TSP		7.0 TSP		7.5 TSP		8.0 TSP	
	RPM	BHP	RPM	BHP	RPM	BHP	RPM	BHP	RPM	BHP	RPM	BHP	RPM	BHP
8,000	—	—	—	—	—	—	—	—	—	—	—	—	—	—
9,000	—	—	—	—	—	—	—	—	—	—	—	—	—	—
10,000	—	—	—	—	—	—	—	—	—	—	—	—	—	—
11,000	1224	14.44	1282	16.18	—	—	—	—	—	—	—	—	—	—
12,000	1227	15.32	1285	17.10	1340	18.94	1394	20.83	—	—	—	—	—	—
13,000	1232	16.25	1289	18.09	1343	19.98	1396	21.92	1448	23.91	1497	25.95	—	—
14,000	1241	17.23	1295	19.14	1348	21.09	1400	23.08	1451	25.12	1500	27.21	1548	29.35
15,000	1255	18.26	1306	20.23	1356	22.25	1406	24.31	1456	26.41	1504	28.56	1551	30.74

**Table 174: 40 ton to 50 ton total static pressure**

CFM	5.0 TSP		5.5 TSP		6.0 TSP		6.5 TSP		7.0 TSP		7.5 TSP		8.0 TSP	
	RPM	BHP	RPM	BHP	RPM	BHP	RPM	BHP	RPM	BHP	RPM	BHP	RPM	BHP
16,000	1273	19.36	1320	21.38	1368	23.46	1416	25.59	1463	27.76	1510	29.97	1556	32.22
17,000	1296	20.51	1340	22.60	1384	24.70	1429	26.92	1474	29.16	1519	31.43	1563	33.75
18,000	1322	21.74	1363	23.89	1405	26.08	1447	28.33	1489	30.62	1531	32.96	1574	35.34
19,000	1351	23.05	1390	25.26	1429	27.51	1468	29.81	1508	32.16	1548	34.56	1588	37.00
20,000	1381	24.44	1419	26.71	1456	29.02	1493	31.38	1530	33.78	1568	36.24	1605	38.73

**Table 175: 60 ton total static pressure**

CFM	1.0 TSP		1.5 TSP		2.0 TSP		2.5 TSP		3.0 TSP		3.5 TSP		4.0 TSP	
	RPM	BHP	RPM	BHP	RPM	BHP	RPM	BHP	RPM	BHP	RPM	BHP	RPM	BHP
12,000	805	3.72	905	5.40	996	7.18	1087	—	—	—	—	—	—	—
13,000	839	4.15	933	5.89	1021	7.79	1103	9.74	1190	11.80	—	—	—	—
14,000	873	4.61	963	6.42	1049	8.41	1128	10.47	1203	12.59	1285	14.84	1369	17.25
15,000	910	5.13	996	7.02	1077	9.06	1155	11.24	1227	13.47	1297	15.75	1373	18.16
16,000	950	5.71	1030	7.68	1107	9.77	1182	12.03	1253	14.38	1321	16.76	1386	19.20
17,000	989	6.33	1064	8.37	1139	10.55	1211	12.86	1280	15.31	1346	17.81	1409	20.35
18,000	1028	7.00	1100	9.13	1173	11.40	1241	13.75	1308	16.27	1373	18.90	1434	21.55
19,000	1067	7.73	1139	9.96	1207	12.29	1273	14.74	1337	17.29	1400	20.00	1461	22.79
20,000	1107	8.51	1179	10.85	1242	13.24	1307	15.79	1368	18.40	1429	21.16	1488	24.04
21,000	1147	9.35	1219	11.80	1278	14.28	1341	16.90	1401	19.60	1459	22.40	1517	25.34
22,000	1188	10.26	1257	12.81	1318	15.40	1376	18.06	1435	20.88	1491	23.73	1546	26.71
23,000	1230	11.23	1296	13.89	1358	16.59	1411	19.33	1469	22.21	1524	25.16	1577	28.19
24,000	1272	12.28	1336	15.03	1398	17.85	1450	20.68	1504	23.60	1558	26.68	1610	29.77

**Table 176: 60 ton total static pressure**

CFM	4.5 TSP		5.0 TSP		5.5 TSP		6.0 TSP		6.5 TSP		7.0 TSP		7.5 TSP		8.0 TSP		8.3 TSP	
	RPM	BHP	RPM	BHP	RPM	BHP	RPM	BHP	RPM	BHP	RPM	BHP	RPM	BHP	RPM	BHP	RPM	BHP
12,000	—	—	—	—	—	—	—	—	—	—	—	—	—	—	—	—	—	—
13,000	—	—	—	—	—	—	—	—	—	—	—	—	—	—	—	—	—	—
14,000	1451	19.81	—	—	—	—	—	—	—	—	—	—	—	—	—	—	—	—
15,000	1452	20.73	1529	23.44	—	—	—	—	—	—	—	—	—	—	—	—	—	—
16,000	1457	21.76	1531	24.49	1604	27.34	1675	30.31	—	—	—	—	—	—	—	—	—	—
17,000	1470	22.94	1537	25.66	1607	28.52	1676	31.51	1744	34.62	—	—	—	—	—	—	—	—
18,000	1494	24.25	1552	26.99	1614	29.83	1680	32.83	1745	35.95	1810	39.19	1873	42.52	—	—	—	—
19,000	1519	25.59	1576	28.43	1630	31.32	1688	34.30	1750	37.42	1812	40.67	1874	44.03	1934	47.49	1970	49.61
20,000	1546	26.98	1601	29.92	1654	32.92	1706	35.96	1760	39.06	1818	42.30	1877	45.67	1936	49.14	1971	51.28
21,000	1573	28.38	1627	31.47	1679	34.56	1731	37.71	1780	40.89	1830	44.12	1884	47.47	1941	50.95	1975	53.09
22,000	1601	29.83	1654	33.03	1706	36.26	1756	39.50	1805	42.79	1852	46.12	1899	49.48	1949	52.94	—	—
23,000	1630	31.35	1682	34.62	1733	37.98	1782	41.36	1830	44.75	1877	48.17	1923	51.64	—	—	—	—
24,000	1660	32.96	1711	36.29	1761	39.72	1809	43.23	1857	46.76	1903	50.29	1948	53.86	—	—	—	—

**Note:**

The CFM, SP, and BHP values are based on two fans for the DDP supply fans ( GEN II 270—9—120)

**Table 177: 70 ton to 80 ton total static pressure**

CFM	1.0 TSP		1.5 TSP		2.0 TSP		2.5 TSP		3.0 TSP		3.5 TSP		4.0 TSP	
	RPM	BHP	RPM	BHP	RPM	BHP	RPM	BHP	RPM	BHP	RPM	BHP	RPM	BHP
14,000	873	4.61	963	6.42	1049	8.41	1128	10.47	1203	12.59	1285	14.84	1369	17.25
15,000	910	5.13	996	7.02	1077	9.06	1155	11.24	1227	13.47	1297	15.75	1373	18.16
16,000	950	5.71	1030	7.68	1107	9.77	1182	12.03	1253	14.38	1321	16.76	1386	19.20
17,000	989	6.33	1064	8.37	1139	10.55	1211	12.86	1280	15.31	1346	17.81	1409	20.35

**Table 177: 70 ton to 80 ton total static pressure**

CFM	1.0 TSP		1.5 TSP		2.0 TSP		2.5 TSP		3.0 TSP		3.5 TSP		4.0 TSP	
	RPM	BHP	RPM	BHP	RPM	BHP	RPM	BHP	RPM	BHP	RPM	BHP	RPM	BHP
18,000	1028	7.00	1100	9.13	1173	11.40	1241	13.75	1308	16.27	1373	18.90	1434	21.55
19,000	1067	7.73	1139	9.96	1207	12.29	1273	14.74	1337	17.29	1400	20.00	1461	22.79
20,000	1107	8.51	1179	10.85	1242	13.24	1307	15.79	1368	18.40	1429	21.16	1488	24.04
21,000	1147	9.35	1219	11.80	1278	14.28	1341	16.90	1401	19.60	1459	22.40	1517	25.34
22,000	1188	10.26	1257	12.81	1318	15.40	1376	18.06	1435	20.88	1491	23.73	1546	26.71
23,000	1230	11.23	1296	13.89	1358	16.59	1411	19.33	1469	22.21	1524	25.16	1577	28.19
24,000	1272	12.28	1336	15.03	1398	17.85	1450	20.68	1504	23.60	1558	26.68	1610	29.77
25,000	1315	13.40	1376	16.25	1436	19.18	1490	22.11	1539	25.10	1592	28.24	1643	31.45
26,000	1358	14.60	1417	17.55	1475	20.57	1530	23.63	1577	26.70	1627	29.87	1677	33.20
27,000	1401	15.89	1458	18.92	1514	22.05	1569	25.22	1616	28.39	1662	31.62	1712	35.00
28,000	1445	17.25	1499	20.38	1554	23.60	1608	26.88	1657	30.17	1700	33.48	1746	36.90
29,000	1489	18.70	1542	21.93	1594	25.24	1646	28.63	1696	32.04	1739	35.45	1782	38.92
30,000	1533	20.25	1584	23.56	1635	26.97	1685	30.46	1735	33.98	1780	37.51	1820	41.06
31,000	1577	21.88	1627	25.29	1676	28.80	1725	32.38	1774	36.01	1819	39.66	1859	43.30
32,000	1622	23.61	1670	27.12	1718	30.72	1765	34.40	1812	38.13	1858	41.89	1900	45.65

**Table 178: 70 ton to 80 ton total static pressure**

CFM	4.5 TSP		5.0 TSP		5.5 TSP		6.0 TSP		6.5 TSP		7.0 TSP		7.5 TSP		8.0 TSP		8.3 TSP	
	RPM	BHP	RPM	BHP	RPM	BHP	RPM	BHP	RPM	BHP	RPM	BHP	RPM	BHP	RPM	BHP	RPM	BHP
14,000	1451	19.81	—	—	—	—	—	—	—	—	—	—	—	—	—	—	—	—
15,000	1452	20.73	1529	23.44	—	—	—	—	—	—	—	—	—	—	—	—	—	—
16,000	1457	21.76	1531	24.49	1604	27.34	1675	30.31	—	—	—	—	—	—	—	—	—	—
17,000	1470	22.94	1537	25.66	1607	28.52	1676	31.51	1744	34.62	—	—	—	—	—	—	—	—
18,000	1494	24.25	1552	26.99	1614	29.83	1680	32.83	1745	35.95	1810	39.19	1873	42.52	—	—	—	—
19,000	1519	25.59	1576	28.43	1630	31.32	1688	34.30	1750	37.42	1812	40.67	1874	44.03	1934	47.49	1970	49.61
20,000	1546	26.98	1601	29.92	1654	32.92	1706	35.96	1760	39.06	1818	42.30	1877	45.67	1936	49.14	1971	51.28
21,000	1573	28.38	1627	31.47	1679	34.56	1731	37.71	1780	40.89	1830	44.12	1884	47.47	1941	50.95	1975	53.09
22,000	1601	29.83	1654	33.03	1706	36.26	1756	39.50	1805	42.79	1852	46.12	1899	49.48	1949	52.94	—	—
23,000	1630	31.35	1682	34.62	1733	37.98	1782	41.36	1830	44.75	1877	48.17	1923	51.64	—	—	—	—
24,000	1660	32.96	1711	36.29	1761	39.72	1809	43.23	1857	46.76	1903	50.29	1948	53.86	—	—	—	—
25,000	1692	34.69	1741	38.06	1789	41.55	1837	45.13	1884	48.78	1929	52.46	—	—	—	—	—	—
26,000	1725	36.53	1772	39.94	1819	43.47	1866	47.11	1911	50.85	1956	54.64	—	—	—	—	—	—
27,000	1759	38.47	1805	41.94	1850	45.51	1895	49.19	1940	52.99	—	—	—	—	—	—	—	—
28,000	1794	40.46	1839	44.05	1883	47.68	1926	51.39	—	—	—	—	—	—	—	—	—	—
29,000	1828	42.52	1873	46.24	1916	49.96	1958	53.73	—	—	—	—	—	—	—	—	—	—
30,000	1863	44.70	1907	48.48	1950	52.34	—	—	—	—	—	—	—	—	—	—	—	—
31,000	1899	47.00	1942	50.82	1984	54.78	—	—	—	—	—	—	—	—	—	—	—	—
32,000	1937	49.44	1977	53.30	—	—	—	—	—	—	—	—	—	—	—	—	—	—

**Note:**

The CFM, SP, and BHP values are based on two fans for the DDP supply fans ( GEN II 270—9—120)

**Exhaust fan data**

**Table 179: 25 ton to 30 ton total static pressure**

CFM	0.5 TSP		1.0 TSP		1.5 TSP		2.0 TSP		2.5 TSP		3.0 TSP	
	RPM	BHP	RPM	BHP	RPM	BHP	RPM	BHP	RPM	BHP	RPM	BHP
5,000	—	—	654	1.82	769	2.49	878	3.33	974	4.08	1060	4.72
6,000	—	—	688	2.46	796	3.24	892	4.01	987	4.97	1074	6.00
7,000	616	2.60	729	3.36	832	4.18	922	5.07	1004	5.94	1087	6.96

**Table 179: 25 ton to 30 ton total static pressure**

CFM	0.5 TSP		1.0 TSP		1.5 TSP		2.0 TSP		2.5 TSP		3.0 TSP	
	RPM	BHP	RPM	BHP	RPM	BHP	RPM	BHP	RPM	BHP	RPM	BHP
8,000	672	3.61	777	4.54	867	5.30	958	6.33	1037	7.35	1109	8.32
9,000	731	4.90	825	5.88	914	6.90	991	7.74	1073	8.94	1145	10.11
10,000	791	6.48	877	7.53	962	8.72	1036	9.73	1106	10.69	1179	12.01
11,000	850	8.38	932	9.52	1009	10.75	1085	12.07	1150	13.11	1213	14.16
12,000	910	10.62	990	11.89	1060	13.17	1131	14.60	—	—	—	—

**Table 180: 40 ton to 50 ton total static pressure**

CFM	0.5 TSP		1.0 TSP		1.5 TSP		2.0 TSP		2.5 TSP		3.0 TSP	
	RPM	BHP	RPM	BHP	RPM	BHP	RPM	BHP	RPM	BHP	RPM	BHP
8,000	293	1.23	399	2.19	487	3.23	559	4.35	—	—	—	—
9,000	302	1.50	400	2.46	488	3.68	561	4.85	625	6.12	682	7.46
10,000	312	1.81	404	2.83	488	4.11	563	5.42	628	6.73	685	8.14
11,000	324	2.20	411	3.31	490	4.51	564	6.03	629	7.44	688	8.89
12,000	338	2.67	420	3.84	494	5.05	565	6.56	630	8.21	689	9.73
13,000	351	3.21	429	4.40	500	5.73	567	7.13	631	8.91	690	10.65
14,000	366	3.82	439	5.03	508	6.50	571	7.89	633	9.56	691	11.52
15,000	381	4.52	451	5.77	518	7.31	577	8.81	636	10.38	692	12.30
16,000	396	5.30	464	6.63	527	8.15	586	9.83	640	11.41	695	13.18
17,000	411	6.17	478	7.58	536	9.08	595	10.90	647	12.60	699	14.31
18,000	427	7.14	492	8.64	548	10.17	604	12.00	656	13.89	704	15.65
19,000	443	8.21	506	9.80	561	11.39	613	13.17	665	15.23	712	17.13
20,000	459	9.39	520	11.08	574	12.73	624	14.49	674	16.59	721	18.70

**Table 181: 60 ton total static pressure**

CFM	0.5 TSP		1.0 TSP		1.5 TSP		2.0 TSP		2.5 TSP		3.0 TSP	
	RPM	BHP	RPM	BHP	RPM	BHP	RPM	BHP	RPM	BHP	RPM	BHP
12,000	257	1.97	335	3.21	—	—	—	—	—	—	—	—
13,000	264	2.27	340	3.65	—	—	—	—	—	—	—	—
14,000	271	2.60	345	4.09	407	5.54	—	—	—	—	—	—
15,000	280	2.98	350	4.55	411	6.09	—	—	—	—	—	—
16,000	289	3.41	357	5.05	416	6.76	470	8.42	—	—	—	—
17,000	297	3.88	364	5.60	421	7.42	473	9.12	—	—	—	—
18,000	306	4.38	371	6.19	427	8.10	478	9.97	525	11.85	—	—
19,000	315	4.93	378	6.82	433	8.82	483	10.87	529	12.73	—	—
20,000	323	5.53	385	7.50	440	9.60	489	11.76	534	13.80	576	15.86
21,000	332	6.19	394	8.26	447	10.43	494	12.68	539	14.92	580	16.96
22,000	342	6.92	402	9.09	454	11.33	501	13.64	544	16.03	585	18.26
23,000	351	7.71	411	9.98	461	12.26	507	14.68	550	17.16	591	19.61
24,000	361	8.57	420	10.93	468	13.26	514	15.78	556	18.34	596	20.94

**Table 182: 70 ton to 80 ton total static pressure**

CFM	0.5 TSP		1.0 TSP		1.5 TSP		2.0 TSP		2.5 TSP		3.0 TSP	
	RPM	BHP	RPM	BHP	RPM	BHP	RPM	BHP	RPM	BHP	RPM	BHP
14,000	271	2.60	345	4.09	407	5.54	—	—	—	—	—	—
15,000	280	2.98	350	4.55	411	6.09	—	—	—	—	—	—
16,000	289	3.41	357	5.05	416	6.76	470	8.42	—	—	—	—
17,000	297	3.88	364	5.60	421	7.42	473	9.12	—	—	—	—
18,000	306	4.38	371	6.19	427	8.10	478	9.97	525	11.85	—	—
19,000	315	4.93	378	6.82	433	8.82	483	10.87	529	12.73	—	—
20,000	323	5.53	385	7.50	440	9.60	489	11.76	534	13.80	576	15.86
21,000	332	6.19	394	8.26	447	10.43	494	12.68	539	14.92	580	16.96

**Table 182: 70 ton to 80 ton total static pressure**

CFM	0.5 TSP		1.0 TSP		1.5 TSP		2.0 TSP		2.5 TSP		3.0 TSP	
	RPM	BHP	RPM	BHP	RPM	BHP	RPM	BHP	RPM	BHP	RPM	BHP
22,000	342	6.92	402	9.09	454	11.33	501	13.64	544	16.03	585	18.26
23,000	351	7.71	411	9.98	461	12.26	507	14.68	550	17.16	591	19.61
24,000	361	8.57	420	10.93	468	13.26	514	15.78	556	18.34	596	20.94
25,000	371	9.50	429	11.92	476	14.34	521	16.95	562	19.58	601	22.29
26,000	381	10.50	437	12.98	484	15.52	528	18.17	569	20.90	607	23.69
27,000	390	11.58	446	14.10	493	16.78	535	19.45	576	22.29	614	25.15
28,000	400	12.74	455	15.29	502	18.11	542	20.81	583	23.76	620	26.69
29,000	410	13.98	464	16.57	511	19.51	551	22.29	590	25.31	627	28.32
30,000	420	15.30	473	17.94	520	20.97	559	23.86	597	26.87	634	30.04
31,000	430	16.71	482	19.40	528	22.49	568	25.53	604	28.55	641	31.83
32,000	440	18.20	492	20.95	537	23.73	577	27.28	612	30.35	648	33.68

**Table 183: 60 ton total static pressure table for dual exhaust fans**

CFM	0.5 TSP		1.0 TSP		1.5 TSP		2.0 TSP		2.5 TSP		3.0 TSP	
	RPM	BHP	RPM	BHP	RPM	BHP	RPM	BHP	RPM	BHP	RPM	BHP
12,000	371	2.09	465	3.01	569	4.23	669	5.63	—	—	—	—
13,000	389	2.52	471	3.42	569	4.69	662	6.09	754	7.68	838	9.3
14,000	407	3.01	481	3.91	568	5.15	657	6.6	742	8.17	829	9.96
15,000	432	3.64	493	4.49	571	5.7	657	7.21	738	8.81	816	10.51
16,000	461	4.42	509	5.16	578	6.34	656	7.83	734	9.46	811	11.25
17,000	490	5.31	525	5.92	587	7.07	658	8.53	735	10.26	805	12
18,000	518	6.3	543	6.77	599	7.91	664	9.35	734	11.03	804	12.88
19,000	547	7.41	561	7.7	614	8.87	672	10.25	736	11.91	805	13.84
20,000	576	8.64	579	8.72	629	9.93	682	11.29	742	12.94	804	14.77
21,000	605	10	625	10.55	646	11.1	695	12.45	749	14.04	807	15.87
22,000	634	11.5	634	11.5	664	12.37	709	13.73	758	15.29	813	17.12
23,000	662	13.14	672	13.45	682	13.76	725	15.15	770	16.68	820	18.45
24,000	691	14.93	696	15.09	700	15.24	742	16.68	784	18.21	830	19.94

**Table 184: 70 ton to 80 ton total static pressure table for dual exhaust fans**

CFM	0.5 TSP		1.0 TSP		1.5 TSP		2.0 TSP		2.5 TSP		3 TSP	
	RPM	BHP	RPM	BHP	RPM	BHP	RPM	BHP	RPM	BHP	RPM	BHP
14,000	335	2.26	443	3.62	539	5.19	629	6.97	—	—	—	—
15,000	346	2.61	444	3.96	538	5.58	629	7.5	703	9.32	—	—
16,000	358	3.02	450	4.39	541	6.08	624	7.92	704	9.98	—	—
17,000	371	3.48	457	4.89	543	6.58	620	8.39	703	10.62	770	12.69
18,000	384	3.98	463	5.39	543	7.08	623	9.03	697	11.12	771	13.5
19,000	398	4.55	468	5.91	547	7.66	625	9.71	694	11.73	768	14.19
20,000	412	5.17	476	6.52	554	8.37	627	10.38	696	12.52	762	14.8
21,000	426	5.86	487	7.22	561	9.13	628	11.05	699	13.36	760	15.58
22,000	443	6.65	498	8.01	567	9.87	632	11.85	700	14.21	763	16.55
23000	463	7.6	511	8.87	572	10.62	639	12.79	701	15.04	765	17.56
24,000	483	8.64	524	9.8	579	11.5	646	13.8	703	15.93	767	18.57
25,000	503	9.76	537	10.79	588	12.48	653	14.8	706	17.01	768	19.57
26,000	524	10.98	550	11.86	599	13.58	657	15.78	716	18.23	769	20.61
27,000	544	12.3	564	13.02	611	14.78	663	16.85	724	19.49	774	21.84
28,000	564	13.71	578	14.26	624	16.06	671	18.06	730	20.74	781	23.25
29,000	584	15.24	593	15.6	637	17.43	681	19.41	734	21.96	789	24.74
30,000	604	16.87	607	17.01	649	18.88	692	20.87	740	23.28	796	26.27
31,000	624	18.61	642	19.52	663	20.42	704	22.46	747	24.76	801	27.74
32,000	644	20.47	656	20.98	676	22.06	716	24.15	757	26.39	805	29.22

## Return fan data

**Table 185: 25 ton to 30 ton total static pressure**

CFM	0.5 TSP		1.0 TSP		1.5 TSP		2.0 TSP		2.5 TSP		3.0 TSP	
	RPM	BHP	RPM	BHP	RPM	BHP	RPM	BHP	RPM	BHP	RPM	BHP
5,000	—	—	—	—	878	2.24	976	3.01	1070	3.86	1158	4.81
6,000	—	—	835	1.96	936	2.76	1026	3.60	1110	4.49	1191	5.43
7,000	—	—	903	2.42	1000	3.37	1085	4.30	1163	5.26	1237	6.28
8,000	872	1.92	976	2.96	1066	4.04	1149	5.11	1224	6.18	1294	7.26
9,000	955	2.40	1051	3.61	1137	4.78	1215	6.00	1288	7.21	1356	8.40
10,000	1042	2.97	1127	4.35	1211	5.63	1285	6.96	1354	8.31	1420	9.66
11,000	1129	3.66	1207	5.16	1285	6.61	1358	8.02	1424	9.50	—	—
12,000	1218	4.49	1290	6.05	1361	7.71	1432	9.24	—	—	—	—

**Table 186: 40 ton to 50 ton total static pressure**

CFM	0.5 TSP		1.0 TSP		1.5 TSP		2.0 TSP		2.5 TSP		3.0 TSP	
	RPM	BHP	RPM	BHP	RPM	BHP	RPM	BHP	RPM	BHP	RPM	BHP
8,000	—	—	—	—	—	—	—	—	—	—	1075	6.94
9,000	—	—	—	—	—	—	—	—	1043	6.39	1109	7.66
10,000	—	—	—	—	—	—	—	—	1086	7.19	1149	8.54
11,000	—	—	—	—	—	—	1065	6.47	1130	7.98	1192	9.50
12,000	—	—	—	—	1048	5.84	1114	7.25	1176	8.79	1236	10.44
13,000	—	—	1034	5.04	1101	6.57	1165	8.16	1224	9.70	1282	11.40
14,000	—	—	1094	5.82	1156	7.37	1218	9.12	1275	10.77	1329	12.47
15,000	1091	5.15	1154	6.70	1213	8.29	1271	10.10	1327	11.96	1380	13.71
16,000	1156	6.02	1215	7.68	1271	9.34	1325	11.16	1380	13.17	1431	15.10
17,000	1220	6.99	1277	8.76	1331	10.51	1382	12.36	1433	14.41	1484	16.55
18,000	1285	8.06	1340	9.96	1391	11.80	1440	13.70	1488	15.76	1537	18.01
19,000	1351	9.25	1403	11.26	1452	13.21	1499	15.18	1544	17.26	1590	19.53
20,000	1416	10.56	1466	12.69	1514	14.75	1559	16.80	1602	18.92	—	—

**Table 187: 60 ton total static pressure**

CFM	0.5 TSP		1.0 TSP		1.5 TSP		2.0 TSP		2.5 TSP		3.0 TSP	
	RPM	BHP	RPM	BHP	RPM	BHP	RPM	BHP	RPM	BHP	RPM	BHP
12,000	667	1.96	745	3.17	812	4.59	876	6.03	936	7.51	998	9.09
13,000	711	2.26	786	3.58	847	5.06	908	6.55	966	8.16	1022	9.77
14,000	755	2.61	825	4.02	884	5.48	942	7.16	998	8.80	1051	10.53
15,000	799	2.99	863	4.48	925	6.01	978	7.79	1031	9.48	1083	11.31
16,000	844	3.43	903	4.99	966	6.63	1015	8.34	1065	10.29	1115	12.09
17,000	889	3.92	945	5.55	1006	7.30	1055	9.00	1101	11.04	1149	13.01
18,000	934	4.45	988	6.15	1043	7.96	1096	9.80	1139	11.73	1184	13.98
19,000	979	5.03	1032	6.81	1082	8.69	1137	10.68	1179	12.57	1220	14.82
20,000	1025	5.65	1076	7.52	1123	9.49	1175	11.55	1220	13.69	1259	15.68
21,000	1071	6.31	1121	8.29	1165	10.35	1212	12.46	1261	14.65	1299	16.74
22,000	1116	7.01	1165	9.13	1208	11.26	1252	13.45	1300	15.76	1340	17.95
23,000	1162	7.75	1210	10.05	1252	12.23	1293	14.51	1337	16.85	1381	19.25
24,000	1208	8.54	1255	11.04	1296	13.27	1335	15.65	1376	18.04	1420	20.58

**Table 188: 70 ton to 80 ton total static pressure**

CFM	0.5 TSP		1.0 TSP		1.5 TSP		2.0 TSP		2.5 TSP		3.0 TSP	
	RPM	BHP	RPM	BHP	RPM	BHP	RPM	BHP	RPM	BHP	RPM	BHP
14,000	755	2.61	825	4.02	884	5.48	942	7.16	998	8.80	1051	10.53
15,000	799	2.99	863	4.48	925	6.01	978	7.79	1031	9.48	1083	11.31
16,000	844	3.43	903	4.99	966	6.63	1015	8.34	1065	10.29	1115	12.09

**Table 188: 70 ton to 80 ton total static pressure**

CFM	0.5 TSP		1.0 TSP		1.5 TSP		2.0 TSP		2.5 TSP		3.0 TSP	
	RPM	BHP	RPM	BHP	RPM	BHP	RPM	BHP	RPM	BHP	RPM	BHP
17,000	889	3.92	945	5.55	1006	7.30	1055	9.00	1101	11.04	1149	13.01
18,000	934	4.45	988	6.15	1043	7.96	1096	9.80	1139	11.73	1184	13.98
19,000	979	5.03	1032	6.81	1082	8.69	1137	10.68	1179	12.57	1220	14.82
20,000	1025	5.65	1076	7.52	1123	9.49	1175	11.55	1220	13.69	1259	15.68
21,000	1071	6.31	1121	8.29	1165	10.35	1212	12.46	1261	14.65	1299	16.74
22,000	1116	7.01	1165	9.13	1208	11.26	1252	13.45	1300	15.76	1340	17.95
23,000	1162	7.75	1210	10.05	1252	12.23	1293	14.51	1337	16.85	1381	19.25
24,000	1208	8.54	1255	11.04	1296	13.27	1335	15.65	1376	18.04	1420	20.58
25,000	1254	9.38	1300	12.09	1340	14.38	1378	16.84	1416	19.32	1458	21.89
26,000	1300	10.26	1346	13.20	1385	15.57	1421	18.10	1457	20.68	1496	23.29
27,000	1347	11.20	1391	14.38	1430	16.85	1465	19.43	1500	22.11	1535	24.79
28,000	1393	12.19	1436	15.62	1475	18.23	1509	20.84	1543	23.61	1576	26.39
29,000	1440	13.25	1482	16.91	1520	19.68	1554	22.34	1586	25.18	1618	28.07
30,000	1486	14.37	1528	18.26	1565	21.22	1598	23.94	1630	26.84	1661	29.82
31,000	1533	15.55	1574	19.67	1610	22.83	1643	25.64	1674	28.58	1704	31.64
32,000	1580	16.80	1619	21.14	1655	24.53	1688	27.44	1718	30.42	1747	33.55

# Electrical data

## Electrical service sizing

In order to determine the electrical service required for the Premier rooftop unit, use the appropriate calculations listed below from U.L. 60335-2-40. Based on the configuration of the unit, the calculations yield different minimum circuit ampacity (MCA) and maximum overcurrent protection (MOP).

Using the following load definitions and calculations, determine the correct electrical sizing for the unit. All concurrent load conditions must be considered in the calculations, and the highest value for any combination of loads must be used.

### Load definitions:

- **LOAD1** is the current of the largest motor – compressor or fan motor.
- **LOAD2** is the sum of the remaining motor currents that may run concurrently with LOAD1.
- **LOAD3** is the current of the electric heaters – zero for cooling only units.
- **LOAD4** is the sum of any remaining currents greater than or equal to 1.0 amp.

Use the following calculations to determine MCA and MOP for units supplied with a single-point power connection:

① **Note:** For electric heat applications, the nameplate MCA/MOP value is the larger of the cooling mode or the heating mode value calculated.

$$\text{MCA} = (1.25 \times \text{Load1}) + (1.25 \times \text{Load3}) + \text{Load2} + \text{Load4}$$

**Exception:** Load3 may be multiplied by 1 if the electric heater is greater than 50 kW

$$\text{MOP} = (2.25 \times \text{Load1}) + \text{Load2} + \text{Load3} + \text{Load4}$$

Use the following calculations to determine MCA and MOP for units supplied with a dual-point power connection:

① **Note:** For electric heat applications, the nameplate MCA 1/MOP 1 value is the larger of the cooling mode or the heating mode value calculated.

Electrical circuit 1: compressors and crankcase heaters, condenser fan motors, electric heat (MCA 1/MOP 1).

Electrical circuit 2: supply fan, return and exhaust fan, ERW, 120 V transformer for lights, UV lights, convenience outlet, and 24 VAC control transformers (MCA 2/MOP 2).

Use the formulas above to calculate MCA and MOP for electrical circuits 1 and 2.

For single or dual point power connection, if the MOP does not equal a standard current rating of an overcurrent protective device, then the marked maximum rating is to be the next lower standard rating. However, if the device selected for MOP is less than the MCA, then select the lowest standard maximum fuse size greater than or equal to the MCA.

## Power supply voltage limits

**Table 189: Power supply voltage limits**

Power supply	Minimum voltage	Maximum voltage
208-230V/3Ph/60Hz	187	253
460V/3Ph/60Hz	414	506
575V/3Ph/60Hz	518	632

## Fixed speed compressor data

**Table 190: Standard efficiency and standard capacity compressor electrical data**

Model	Compressor	Nominal voltage					
		208-230/3/60*		460/3/60		575/3/60	
		RLA	LRA	RLA	LRA	RLA	LRA
25 ton	1A	34	240	16	140	12.9	107.6
	2A	15.6	110	7.8	52	5.8	38.9
	2B	25	164	12.2	100	9	78

**Table 190: Standard efficiency and standard capacity compressor electrical data**

Model	Compressor	Nominal voltage					
		208-230/3/60*		460/3/60		575/3/60	
		RLA	LRA	RLA	LRA	RLA	LRA
30 ton	1A	25	164	12.2	100	9	78
	1B	25	164	12.2	100	9	78
	2A	22.4	149	10.6	75	7.7	54
	2B	27.6	191	12.8	101	9.6	78
40 ton	1A	48.1	245	18.6	125	14.7	100
	1B	22.4	149	10.6	75	7.7	54
	2A	34	240	16	140	12.9	107.6
	2B	28.2	240	14.7	130	11.3	93.7
50 ton	1A	29.5	195	14.7	95	12.2	80
	1B	55.8	340	26.9	173	23.7	132
	2A	48.1	245	18.6	125	14.7	100
	2B	34	240	16	140	12.9	107.6
60 ton	1A	41	304	19.2	147	16.7	122
	1B	48.1	351	24.7	197	22.4	135
	2A	41	304	19.2	147	16.7	122
	2B	48.1	351	24.7	197	22.4	135
70 ton	1A	39.1	267	18.6	142	15.4	103
	1B	67.3	485	32.7	215	26.3	175
	2A	48.1	351	24.7	197	22.4	135
	2B	48.1	351	24.7	197	22.4	135
80 ton	1A	48.1	351	24.7	197	22.4	135
	1B	48.1	351	24.7	197	22.4	135
	2A	48.1	351	24.7	197	22.4	135
	2B	67.3	485	32.7	215	26.3	175

**① Note:**

\* 208 V to 230 V amps are based on 230 V operation.

**Table 191: Standard efficiency and high capacity compressor electrical data**

Model	Compressor	Nominal voltage					
		208-230/3/60*		460/3/60		575/3/60	
		RLA	LRA	RLA	LRA	RLA	LRA
25 ton	1A	34	240	16	140	12.9	107.6
	2A	19	123	9.7	62	7.4	50
	2B	27.6	191	12.8	101	9.6	78
30 ton	1A	28.2	240	14.7	130	11.3	93.7
	1B	22.4	149	10.6	75	7.7	54
	2A	25	164	12.2	100	9	78
40 ton	2B	25	164	12.2	100	9	78
	1A	51.3	300	23.1	150	19.9	109
	1B	25	164	12.2	100	9	78
	2A	34	240	16	140	12.9	107.6
50 ton	2B	28.2	240	14.7	130	11.3	93.7
	1A	30.1	225	16.7	114	12.2	80
	1B	55.8	340	26.9	173	23.7	132
	2A	29.5	195	14.7	95	12.2	80
50 ton	2B	55.8	340	26.9	173	23.7	132

**Table 191: Standard efficiency and high capacity compressor electrical data**

Model	Compressor	Nominal voltage					
		208-230/3/60*		460/3/60		575/3/60	
		RLA	LRA	RLA	LRA	RLA	LRA
60 ton	1A	44.2	315	22.4	158	18.5	136
	1B	48.1	351	24.7	197	22.4	135
	2A	44.2	315	22.4	158	18.5	136
	2B	48.1	351	24.7	197	22.4	135
70 ton	1A	48.1	351	24.7	197	22.4	135
	1B	48.1	351	24.7	197	22.4	135
	2A	48.1	351	24.7	197	22.4	135
	2B	67.3	485	32.7	215	26.3	175
80 ton	1A	48.1	351	24.7	197	22.4	135
	1B	67.3	485	32.7	215	26.3	175
	2A	48.1	351	24.7	197	22.4	135
	2B	67.3	485	32.7	215	26.3	175

**Note:**

\* 208 V to 230 V amps are based on 230 V operation.

## Variable speed drive compressor data

**Table 192: High efficiency and standard capacity compressor electrical data**

Model	Compressor	Nominal voltage								
		208-230/3/60*			460/3/60			575/3/60		
		RLA	Input A	LRA	RLA	Input A	LRA	RLA	Input A	LRA
25 ton	VSD <sup>2,3</sup>	-	50.4	-	-	26	-	-	26	-
	2A	19	-	123	9.7	-	62	7.4	-	50
	2B	27.6	-	191	12.8	-	101	9.6	-	78
30 ton	VSD <sup>2,3</sup>	-	80	-	-	60	-	-	37.6	-
	2A	25	-	164	12.2	-	100	9	-	78
	2B	25	-	164	12.2	-	100	9	-	78
40 ton	VSD <sup>2,3</sup>	-	50.4	-	-	26	-	-	26	-
	1B	39.1	-	267	18.6	-	142	15.4	-	103
	2A	27.6	-	203	14.1	-	98	11.5	-	84
	2B	27.6	-	203	14.1	-	98	11.5	-	84
50 ton	VSD <sup>2,3</sup>	-	80	-	-	36	-	-	37	-
	1B	41	-	304	19.2	-	147	16.7	-	122
	2A	39.1	-	267	18.6	-	142	15.4	-	103
	2B	39.1	-	267	18.6	-	142	15.4	-	103
60 ton	VSD <sup>2,3</sup>	-	80	-	-	36	-	-	37	-
	1B	48.1	-	351	24.7	-	197	22.4	-	135
	2A	39.1	-	267	18.6	-	142	15.4	-	103
	2B	48.1	-	351	24.7	-	197	22.4	-	135
70 ton	VSD <sup>2,3</sup>	-	104	-	-	47	-	-	37	-
	1B	48.1	-	351	24.7	-	197	22.4	-	135
	2A	44.2	-	315	22.4	-	158	18.6	-	136
	2B	48.1	-	351	24.7	-	197	22.4	-	135
80 ton	VSD <sup>2,3</sup>	-	104	-	-	47	-	-	37	-
	1B	48.1	-	351	24.7	-	197	22.4	-	135
	2A	48.1	-	351	24.7	-	197	22.4	-	135
	2B	48.1	-	351	24.7	-	197	22.4	-	135

**Note:**

1. 208 V to 230 V amps are based on 230 V operation.
2. Variable speed drive compressor on circuit 1A.
3. Input A supplied for maximum input current to compressor VFD.

## Condenser fan motor

**Table 193: Condenser fan motor 25 ton to 80 ton**

Unit configurations					Each motor data	208-230V/3Ph/60Hz *		460V/3Ph/60Hz		575V/3Ph/60Hz	
						SS FLA	VFD IN A	SS FLA	VFD IN A	SS FLA	VFD IN A
						7.2	9.5	3.4	4.3	1.7	3.9
Condenser fan option	Unit size	Comp config	Total quantity of fans	Quantity SS fans	Quantity VFD fans	Total fan amps					
Standard ambient	25 ton	All configurations	2	1	1	16.7	7.7	5.6			
	30 ton	High efficiency / standard capacity									
		Standard efficiency / standard capacity	2	0	2	19	8.6	7.8			
	Standard efficiency / High capacity										
	40 ton	All configurations	4	4	0	28.8	13.6	6.8			
	50 ton	All configurations									
Low ambient	25 ton	All configurations	2	0	2	19	8.6	7.8			
	30 ton										
	40 ton		4	2	2	33.4	15.4	11.2			
	50 ton										
Standard ambient	60 ton	All configurations	4	4	0	28.8	13.6	6.8			
	70 ton to 80 ton	All configurations	6	6	0	43.2	20.4	10.2			
Low ambient	60 ton	All configurations	4	2	2	33.4	15.4	11.2			
	70 ton to 80 ton	All configurations	6	4	2	47.8	22.2	14.6			

**Note:**

\* 208 V to 230 V amps are based on 230 V operation.

# Electric heat

**Table 194: Electric heat amp draw**

Capacity	Type of heat	Heater nominal kW	Each stage kW	Steps	208-230V/3Ph/60Hz*	460V/3Ph/60Hz	575V/3Ph/60Hz
					AMPS	AMPS	AMPS
25 ton to 30 ton	Low heat	50	16.7	3	115.3	-	-
	Low heat with SCR**			3***			
	Low heat	60	20	3	-	69.2	55.3
	Low heat with SCR**			3***			
	High heat	100	16.7	6	230.5	-	-
	High heat with SCR**			6***			
	High heat	120	20	6	-	138.3	110.7
High heat with SCR**	6***						
40 ton to 50 ton	Low heat	60	15	4	138.3	-	-
	Low heat with SCR**			4***			
	Low heat	80	20	4	-	92.2	73.8
	Low heat with SCR**			4***			
	High heat	120	15	8	276.6	-	-
	High heat with SCR**			8***			
	High heat	160	20	8	-	184.4	147.5
High heat with SCR**	8***						
60 ton to 80 ton	Low heat	90	15	6	207.49	-	-
	Low heat with SCR**			6***			
	Low heat	120	20	6	-	137.63	110.55
	Low heat with SCR**			6***			
	High heat	120	15	8	276.65	-	-
	High heat with SCR**			8***			
	High heat	200	20	10	-	229.39	184.43
High heat with SCR**	10***						

**Note:**

\* 208 V to 230 V amps are based on 230 V operation.

\*\* Silicon Controlled Rectifier (SCR) is a modulating electric heat option.

\*\*\* SCR electric heat is installed on the first stage of the unit and provides modulation from 0-100%

## Supply fan and return and exhaust fan motor data

**Table 195: 25 ton to 50 ton premium efficiency - ODP**

Motor HP		Nominal voltage		
		208-230/3/60*	460/3/60	575/3/60
		FLA	FLA	FLA
Supply fan motor **	5	14	6.6	5.3
	7.5	20.4	9.7	8
	10	26	12.5	10
	15	38	18	14.2
	20	52	24	19.1
	25	64	30	24.5
	30	76	36	29
	40	99	49	40
Return and exhaust fan motor	50	121	57	46
	3	8.5	4.2	3.4
	5	14	6.6	5.3
	7.5	20.4	9.7	8.0
	10	26	12.5	10.0
	15	38	18	14.2
	20	52	24	19.1

**Table 196: 60 ton to 80 ton premium efficiency - ODP**

Motor HP		Nominal voltage		
		208-230/3/60*	460/3/60	575/3/60
		FLA	FLA	FLA
Supply fan motor (each) **	5	13.2	6.6	5.3
	7.5	19.4	9.7	8
	10	25	12.5	10
	15	36	18	14.2
	20	48	24	19.1
	25	60	30	24.5
	30	72	36	29
	40	98	49	40
Return fan motor**	7.5	19.7	9.9	7.88
	10	25.2	12.6	10.1
	15	36.9	18.5	14.8
	20	48.5	24.3	19.4
	25	57.5	28.7	23
	30	68.6	34.3	27.4
Exhaust fan motor	40	92.6	46.3	37
	5	13.2	6.6	5.3
	7.5	19.4	9.7	8.01
	10	25	12.5	10
	15	36	18	14.2
	20	48	24	19.1
	25	60	30	24.5
	30	72	36	29
	40	98	49	40

**Table 196: 60 ton to 80 ton premium efficiency - ODP**

Motor HP		Nominal voltage		
		208-230/3/60*	460/3/60	575/3/60
		FLA	FLA	FLA
Exhaust fan motor with VFD	5	14.1	7.5	6.2
	7.5	21	10.3	9.2
	10	31.1	13.9	12.5
	15	45.1	20.2	17.3
	20	58	27.2	23.6
	25	71.5	32.3	28.3
	30	83.7	38.1	34.6
	40	114.7	54.1	47.2

**Table 197: 25 ton to 50 ton - premium efficiency - TEFC**

Motor HP		Nominal voltage		
		208-230/3/60*	460/3/60	575/3/60
		FLA	FLA	FLA
Supply fan motor **	5	13.9	6.7	5.3
	7.5	20	9.5	7.6
	10	25.4	12	9.6
	15	38	18.1	14.6
	20	52	24	19.2
	25	64	31	24
	30	78	38	29
	40	102	48	39
Return and exhaust fan motor	3	9	4.2	3.3
	5	13.9	6.7	5.3
	7.5	20	9.5	7.6
	10	25.4	12	9.6
	15	38	18.1	14.6
	20	52	24	19.2

**Table 198: 60 ton to 80 ton - premium efficiency - TEFC**

Motor HP		Nominal voltage		
		208-230/3/60*	460/3/60	575/3/60
		FLA	FLA	FLA
Supply fan motor (each) **	5	13.4	6.7	5.3
	7.5	19	9.5	7.6
	10	24	12	9.6
	15	36.2	18.1	14.6
	20	48	24	19.2
	25	62	31	24
	30	76	38	29
	40	96	48	39
Return fan motor**	7.5	19.1	9.59	7.67
	10	25.6	12.8	10.23
	15	36.4	18.2	14.56
	20	48.6	24.3	19.45
	25	58.2	29.1	23.26
	30	68.6	34.3	27.44
	40	92.6	46.3	37.02

**Table 198: 60 ton to 80 ton - premium efficiency - TEFC**

Motor HP		Nominal voltage		
		208-230/3/60*	460/3/60	575/3/60
		FLA	FLA	FLA
Exhaust fan motor	5	13.4	6.7	5.3
	7.5	19	9.5	7.6
	10	24	12	9.6
	15	36.2	18.1	14.6
	20	48	24	19.2
	25	62	31	24
	30	76	36	29
	40	96	48	39
Exhaust fan motor with VFD	5	14.1	7.5	6.2
	7.5	21	10.3	9.2
	10	31.1	13.9	12.5
	15	45.1	20.2	17.3
	20	58	27.2	23.6
	25	71.5	32.3	28.3
	30	83.7	38.1	34.6
	40	114.7	54.1	47.2

**Note:**

\* 208 V to 230 V amps are based on 230 V operation.

\*\* Actual unit nameplate amps are based on operating conditions and are calculated based on a supply fan amp value that may be less than the maximum amp values shown in the table. See the selection program output for supply fan amps. See the selection program output for return fan amps (60 ton to 80 ton units).

## ERW motor data

**Table 199: ERW motor**

Model	Type	Nominal voltage		
		208-230/3/60*	460/3/60	575/3/60
		FLA	FLA	FLA
25 ton	Low CFM ERW	0.88	0.44	0.46
	High CFM ERW	0.88	0.44	0.46
30 ton	Low CFM ERW	0.88	0.44	0.46
	High CFM ERW	0.88	0.44	0.46
40 ton	Low CFM ERW	0.88	0.44	0.46
	High CFM ERW	2.2	1.1	0.88
50 ton	Low CFM ERW	0.88	0.44	0.46
	High CFM ERW	2.2	1.1	0.88
60 ton	Low CFM ERW	2.6	1.3	1.2
	High CFM ERW	2.6	1.3	1.2
70 ton	Low CFM ERW	2.6	1.3	1.2
	High CFM ERW	2.6	1.3	1.2
80 ton	Low CFM ERW	2.6	1.3	1.2
	High CFM ERW	2.6	1.3	1.2

**Note:**

\* 208 V to 230 V amps are based on 230 V operation.

## Miscellaneous data

**Table 200: Miscellaneous data**

Description	Nominal voltage		
	208-230/3/60*	460/3/60	575/3/60
	AMPS	AMPS	AMPS
Control transformer 0.2 kVA	1.0	0.5	0.5
Convenience outlet	9.0	4.5	3.5
Gas heat (per module)	0.92	0.46	0.37
250 MBH	0.92	0.46	0.37
500 MBH	0.92	0.46	0.37
750 MBH	1.84	0.92	0.74
1000 MBH	1.84	0.92	0.74
1250 MBH	2.76	1.38	1.10
1500 MBH	2.76	1.38	1.10
Crankcase heater 90W	0.3	0.2	0.1
Ultraviolet (UV) lights 25 ton to 50 ton	4.5	2.1	1.7
Ultraviolet (UV) lights 60 ton to 80 ton	9.7	4.4	3.6
Internal lights (per light)	0.05	0.03	0.02

**Note:**

\* 208 V to 230 V amps are based on 230 V operation.

# Controls

## General

The control system for the Premier unit is fully self-contained. To aid in unit setup, maintenance, and operation, the unit controller is equipped with a standard user interface (UI) that has a 5 row × 35 character organic light-emitting diode (OLED) display. The OLED display presents plain language text in a menu-driven format to facilitate use. An optional color, thin film transistor (TFT) with multi-touch capacitive touchscreen and 1280 × 800 resolution is also available to order factory installed or to field install. The touchscreen display details all operations and parameters using an interactive graphical representation of the rooftop unit and its major components.

The unit controller can be connected to and operated by a building automation system (BAS). In addition, hard wired control options to the unit controller are provided using a customer terminal board.

The unit controller uses the latest technology and provides complete control for the unit along with standard BACnet® MS/TP and BACnet IP, Modbus™, and N2 communications. The unit controller also has a USB flash drive that can be used to capture historic data on unit operation and to update firmware.

## Unit mode

### Unit type

The controller supports two rooftop types: multi zone variable air volume (MZVAV) and single zone VAV (SZVAV). Both types can be configured to operate in several different modes of occupancy, temperature control, warm-up/cool down, and automated demand response.

### Occupancy modes

Depending on the application, the controller can be indexed between occupied, unoccupied, optimal start, or coast modes of operation. These occupancy modes are initiated automatically via an internal schedule or externally from a BAS command, hard wired input, or tenant override via zone sensor.

### Sensors

#### Temperature control sensor

The controller compares the discharge air temperature (DAT) against a setpoint to determine the heating or cooling demand. On multi zone VAV

units, the DAT setpoint can be reset by different methods: fixed, outside air temperature (OAT), supply fan speed, external control, zone, or return air temperature (RAT). See also [DAT setpoint reset](#).

#### Changeover sensor

The controller compares this temperature against a setpoint to determine whether to place the unit in heating, cooling, or idle mode. Zone temperature or RAT—or a BAS input—can be used as the changeover sensor.

#### Mandatory sensors

The following sensors are required to make the unit operate and are included as standard on every rooftop.

- Discharge air temperature
- Return air temperature
- Outside air temperature
- Mixed air temperature

#### Optional sensors

Depending on the application, additional sensors may be required.

- Zone air temperature
- Zone humidity
- Enthalpy sensor (for use with economizer)
- Dual enthalpy sensors (measures enthalpy of outdoor air and return air; used with economizer)
- Supply duct pressure (VAV units)
- Building pressure (required for exhaust/return fan)
- Carbon dioxide (CO<sub>2</sub>) (required for demand ventilation)
- Smoke detector

## Warm-up and cool down methods

The warm-up and cool down feature supports three methods of initiating the warm-up and cool down mode: occupied command, schedule, optimal start.

### Occupied command

When the occupancy status for a unit switches to occupied mode, the supply fan turns ON for a 5-minute stabilization period, after which the RAT sensor compares to the warm-up setpoint. If the value is equal to or below the warm-up setpoint, heating is controlled to the warm-up DAT setpoint. If the value is above the warm-up setpoint, the control goes into occupied mode. Warm-up stays active

until the RAT sensor is above the warm-up setpoint for 5 minutes or the early start period expires. The control goes into occupied mode thereafter. Cool down operates opposite of warm-up, using cooling instead of heating stages.

## Schedule

At the early start period, prior to the scheduled occupancy, the supply fan turns ON for a 5-minute stabilization period and then the RAT sensor is compared to the warm-up set point. If the value is equal to or below the warm-up setpoint, heating is controlled to the warm-up DAT setpoint. If the value is above the warm-up setpoint, the control goes into occupied mode. Cool down operates opposite of warm-up, using cooling instead of heating stages.

## Optimal start

The optimal start control algorithm is a function of the difference between zone temperature and occupied temperature setpoint, the OAT, and the amount of time prior to scheduled occupancy.

When unoccupied, the controller calculates an early start time based on control temperature deviation from occupied temperature setpoint. This ensures the space is at conditioned levels when the occupied period starts.

Historical data determines when optimal start begins, but the early start time can be user limited. The optimal start time is always within the same calendar day. The warm-up or cool down DAT setpoints function until the demand is satisfied. The control uses the heating or cooling setpoint to determine when the demand is satisfied. The control goes into occupied mode thereafter.

## Coast

When enabled, 1 hour (adjustable) prior to the transition from occupied to unoccupied, the operational cooling and heating setpoints begin to increase or decrease linearly at 1.0°F per hour (adjustable) towards unoccupied cooling and heating setpoints. The operational cooling and heating DAT setpoints also begin to increase or decrease linearly at 1.0°F per hour (adjustable). During this time, the fans continue to run and the ventilation sequence remains active.

## Multiple unit staggered start

When enabled, the start-up delay utilizes the minimum OFF time plus a delay time. This is used to prevent all units on a site from restarting simultaneously after a power failure.

The delay time can be manually set or randomized between 0–60 seconds. If staggered, start override time is set to 0 seconds.

Additional functionality includes applying a start-up delay when switching into the occupied mode. This only happens if the supply fan command is currently OFF when the occupancy mode switches into occupied. This staggers start-up for multiple rooftop units if all are commanded from the same occupied command. After the timer has expires, the rooftop unit can start.

## Automated demand response methods

The controller is capable of three automated demand response methods: demand shed, load shed, and capacity limit.

### Demand shed

This strategy operates by offsetting the operating cooling setpoint higher and offsetting the operating heating setpoint lower when the unit controller receives a demand shed signal from a binary hard wired input or BAS command. The offset is adjustable.

### Load shed

This function shuts down all cooling and electric heat for an adjustable time period in response to a BAS command.

### Capacity limit

This strategy operates by limiting total allowed mechanical cooling or electric heat capacity in proportion to the value of an analog BAS cooling/heating capacity limit signal.

## Supply air system

The supply fan is used to circulate air to condition the temperature of the space and to provide ventilation to the space. Supply fan starts and operating hours are measured under all operating conditions. Two user-selectable supply air modes are available: MZVAV and SZVAV.

### Multizone variable air volume (MZVAV)

#### Duct pressure control

When the fan energizes, the output from the controller maintains the supply duct pressure to the duct pressure setpoint. If the duct pressure is greater than the duct pressure setpoint, the supply fan output decreases.

If the duct pressure is below the duct pressure setpoint, the supply fan output increases. If the duct pressure reaches the duct pressure shutdown

setpoint, the fan and all other outputs of the unit de-energize.

- ① **Note:** If the unit is in a heating mode, the controller continues to vary supply fan output to control duct pressure to the duct static pressure setpoint. Therefore, in any VAV heating mode, all VAV boxes must be commanded open far enough to get adequate airflow to support the heating function and to prevent the heat section high temperature limit switches from opening. A VAV box binary output on the customer terminal board energizes any time a MZVAV unit is in any heating mode.

### DAT setpoint reset

The DAT setpoint reset feature provides five different methods of varying the DAT setpoint: fixed, OAT, zone and RAT temperature, supply fan speed, and external control.

**Fixed** - The DAT setpoint is a fixed value and does not change in response to another signal. It can be user adjusted from the default value over a BAS or local UI.

### OAT

- **Cooling** - The DAT setpoint is reset from cooling DAT upper setpoint to cooling DAT lower setpoint as the operating OAT varies from OAT lower setpoint to OAT upper setpoint.
- **Heating** - The DAT setpoint is reset from heating DAT lower setpoint to heating DAT upper setpoint as the operating OAT varies from OAT upper setpoint to OAT lower setpoint.

### Zone and return air temperature -

- **Cooling** - The DAT setpoint resets from cooling DAT upper setpoint to the cooling DAT lower setpoint as the zone and return air temperature varies from the zone and return air temperature lower setpoint to the upper zone and return air temperature setpoint.
- **Heating** - The DAT setpoint resets from heating DAT lower setpoint to the heating DAT upper setpoint as the zone and return air temperature varies from the zone and return air temperature upper setpoint to the lower zone and return air temperature setpoint.

- ① **Note:** If zone temperature sensor becomes unreliable or is not installed, the operating zone temperature uses the RAT instead.

### Supply fan speed -

- **Cooling** - The cooling DAT setpoint is reset from DAT cooling upper setpoint to lower setpoint as the supply fan output varies from supply fan DAT lower threshold setpoint to supply fan DAT upper threshold setpoint.
- **Heating** - The heating DAT setpoint is reset from DAT heating lower setpoint to upper setpoint as the supply fan output varies from supply fan DAT lower threshold setpoint to supply fan DAT upper threshold setpoint.

**External control** - The DAT setpoint is controlled directly by a third party - BACnet communication or voltage signal. For cooling mode, the hard-wired DAT setpoint varies from DAT upper setpoint to DAT lower setpoint as the input varies from low value to high value. For heating mode, the hard-wired DAT setpoint varies from DAT lower setpoint to DAT upper setpoint as the input varies from low value to high value.

### Single zone variable air volume (SZVAV)

#### Mechanical cooling

**Zone temperature control** - The DAT setpoint resets between high and low cooling setpoints based on the zone cooling demand. Staged cooling command is based on the time and temperature differential that operating zone temperature has been operating above cooling setpoint. The unit controls the DAT by staging or modulating the compressors. The supply fan runs at the minimum cooling speed setpoint.

As the zone cooling demand increases and the DAT controls to the low cooling setpoint, the supply fan output resets between minimum cooling speed and 100% to maintain the zone temperature at cooling zone temperature setpoint.

**Staged temperature control** - The unit can be controlled by a standard two-stage cooling/heating thermostat. Thermostat connections are hard wired through the customer terminal board: G, Y1, Y2, W1, W2. Thermostat commands can also be communicated by the BAS. The fan operates at minimum or maximum speed in occupied/unoccupied mode based on the thermostat input.

#### Economizer

When free cooling is available, the outside air (OA) damper modulates to maintain the mixed air temperature (MAT) at the cooling DAT setpoint. During the free cooling mode, if the OA damper modulates to 100% open and cannot maintain the cooling DAT setpoint, the compressors are staged or modulated to maintain the cooling DAT setpoint. The supply fan runs at the minimum cooling speed setpoint.

If the zone temperature exceeds the cooling zone temperature setpoint, the OA damper is 100% open, and all cooling stages are staged ON (or locked out due to compressor lockout), then the supply fan resets between minimum cooling speed and 100% to maintain zone temperature at the cooling zone temperature setpoint.

### Satisfied

If the occupancy mode is occupied without a heating or cooling demand, the supply fan runs at the fan only minimum fan speed.

### Modulated heating

The DAT setpoint resets between low and high heating setpoints based on the zone heating demand. The heating command is based on the time and temperature differential that the operating zone temperature has been operating below operating heating setpoint. The unit controls the DAT by modulating the heat (electric, gas, or hydronic). The supply fan runs at the minimum speed setpoint.

As the zone heating demand increases and the DAT controls to the high heating setpoint, the supply fan resets between heating minimum speed and 100% to maintain the zone temperature at heating zone temperature setpoint.

### Staged heating

The DAT setpoint resets between low and high heating setpoints based on the zone heating demand. Staged heating command is based on the time and temperature differential that the operating zone temperature has been operating below operating heating setpoint. The unit controls the DAT by staging the heat (electric or gas). The supply fan runs at maximum capacity.

### Unoccupied mode

If the occupancy mode is unoccupied, the unit does not operate in SZVAV mode but instead operates in the following manner:

#### A. Unoccupied cooling

- The unit controls to the unoccupied zone cooling setpoint.
- The cooling DAT setpoint is set to the cooling setpoint. The unit controls the DAT to the operating cooling DAT setpoint by staging or modulating the compressors. The supply fan runs at maximum capacity.

#### B. Unoccupied heating

- The unit controls the zone temperature to the unoccupied zone heating setpoint.

- The heating DAT setpoint is set to the high heating DAT setpoint. The unit controls the DAT to the operating heating DAT setpoint by staging or modulating the heat (electric, gas or hydronic). The supply fan runs at maximum capacity.

## Exhaust air (EA) system

To control building pressure, three power exhaust control options are available: none, barometric damper, modulating exhaust fan, modulating EA damper with fan, and external control.

### None

The unit does not have an exhaust option.

### Barometric damper

A mechanical barometric damper relief damper is installed, however this damper is not controlled by the units controller.

### Modulating exhaust fan VFD

If the building pressure is greater than the building pressure setpoint, the exhaust fan analog output increases. If the building pressure is less than the building pressure setpoint, the exhaust fan analog output decreases.

Variable speed exhaust fan command is energized any time the exhaust fan speed output is greater than exhaust fan speed on (adjustable) and the fan command is de-energized any time the exhaust fan speed output is less than exhaust fan speed off (adjustable). A minimum deadband between the on and off setpoints is enforced.

### Dual powered exhaust with VFD

Dual DWDI forward-curved centrifugal exhaust fans are provided to exhaust building return air to relieve building static pressure on 60 ton to 80 ton units with an ERW. If the building pressure is greater than the building pressure setpoint, the exhaust fan analog output increases. If the building pressure is less than the building pressure setpoint, the exhaust fan analog output decreases. If ERW command is off, variable speed exhaust fans 1 and 2 commands are energized any time the exhaust fan speed output is greater than exhaust fan speed on (adjustable) and the fan commands are de-energized any time the exhaust fan speed output is less than exhaust fan speed off (adjustable). If ERW command is on, variable speed exhaust fan 1 command is energized any time the exhaust fan speed output is greater than exhaust fan speed on (adjustable) and the fan command is de-energized any time the exhaust fan speed output is less than

exhaust fan speed off (adjustable). Exhaust fan 2 command is off during this time.

### Modulating EA damper with fan (on/off)

The controller modulates the opening of the EA damper to maintain the building pressure setpoint. If the building pressure is greater than the building pressure setpoint, the EA damper output increases to open the EA damper. If the building pressure is less than the building pressure setpoint, the EA damper output decreases to close the EA damper.

Exhaust fan is energized when the exhaust damper is greater than exhaust damper position for exhaust fan to turn on (adjustable), the controller energizes the exhaust fan. If the exhaust damper is less than exhaust damper position for exhaust fan to turn off (adjustable), the controller de-energizes the exhaust fan. To reduce fan cycling, a minimum deadband is enforced between the fan start and fan stop setpoints.

### External control

Exhaust fan speed or EA damper position is controlled directly by a third party (BACnet communication or voltage signal).

## Return air (RA) system

Two return fan control options are available: return fan discharge pressure control and supply fan airflow tracking.

In either return fan mode, the controller modulates the opening of the EA damper to maintain the building pressure at setpoint. If the building pressure is above the building pressure setpoint, the EA damper output increases. If the building pressure is below the building pressure setpoint, the EA damper output decreases. In this mode, the EA damper position can alternatively be controlled directly by a third party (BAS communication or voltage signal).

### Return fan discharge pressure

The controller modulates the speed of the return fan to maintain the return fan discharge pressure to a setpoint. As the supply fan speed increases or the RA or EA dampers open, the return fan discharge pressure decreases, and the return fan speed increases to maintain the pressure setpoint. As the supply fan speed decreases or the RA or EA dampers close, the return fan discharge pressure increases and the fan speed decreases to maintain the operating pressure setpoint. The operating pressure setpoint is a calculated value based on OA damper position and supply fan speed, fan pressure high and low setpoint.

## Supply fan airflow tracking

When equipped with optional supply and return fan airflow measuring stations, the controller monitors the supply fan airflow and modulates the speed of the return fan to a return airflow setpoint. The return airflow setpoint is a calculated value based on the supply fan airflow, minus a return airflow differential (adjustable). If the return fan airflow decreases below the operating flow setpoint, the return fan speed increases. If the return fan airflow increases above the operating flow setpoint, the return fan speed decreases.

## Cooling system

The controller supports both staged and variable speed direct expansion (DX) cooling.

### DX cooling

#### Capacity control

Constant speed compressors stage up or down with the staged cooling command parameter to control the DAT to operating cooling setpoint. During dehumidification control, the compressors switch to evaporator temperature control.

When equipped with a variable speed drive compressor, the capacity modulates via vernier control. The first stage on refrigeration circuit one is variable speed, while all other stages are constant speed. Start count equalization does not apply to the variable speed compressor. The variable speed compressor is always the first compressor ON and last compressor OFF, except in dehumidification mode.

#### Compressor staging algorithm

The controller employs patented algorithms to sequence the compressor stages as a method of quickly meeting cooling demand while reducing overshoot as DAT reaches operating cooling setpoint.

The controller excludes staging combinations that result in one refrigeration circuit having two or more compressors energized than the other refrigeration circuit.

#### Rapid start

To shorten the time it takes to get compressors running, the optimum stage up algorithm is used. It estimates the number of compressor steps required to meet the initial cooling demand and quickly starts the appropriate number of compressors. When the unit first starts up or after an unoccupied to occupied transition, if there are no compressors running and the economizer is not suitable, rapid start is active for the first 5 minutes (adjustable)

of cooling operation. During rapid start, the inter-stage delay time between compressors reduces to 15 seconds.

### Variable speed drive compressors

Envelope control keeps the variable speed drive compressor within the allowable range of saturated suction and saturated discharge temperature for the compressor. Oil management algorithms are designed to keep the oil level above the minimum on variable speed drive compressors. Overall cooling demand, oil management, saturated DAT, and saturated suction temperature all influence the allowable operational speed of the variable speed drive compressor. The controller monitors each of those requirements to provide the appropriate minimum and maximum speeds to the compressor.

### Condensate overflow alarm

When the condensate overflow switch alarm is ON, the unit disables mechanical cooling. Supply fan operation remains enabled during this period. The alarm must be manually reset at the controller.

### Condenser system

The rooftop unit condenser fan control is designed to control staged and modulating condenser fans based on the saturated liquid line temperature. Constant speed condenser fans are staged up or down based on the saturated liquid line temperature. Condenser fan start count equalization is used for fixed speed fans.

### Saturated liquid line temperature control

After a stabilization period of 60 seconds during saturated liquid temperature control and after the first compressor is energized, condenser fans are staged ON or OFF to achieve stage up or down setpoint. If saturated liquid line temperature is above the stage up setpoint, an additional condenser fan is energized. If saturated liquid line temperature falls below the stage down setpoint, a condenser fan is de-energized.

The variable speed fan is the first ON and the last OFF when optionally equipped on the unit. The variable speed fan modulates condenser fan speed between 80.0–110.0°F.

If saturated liquid line temperature becomes unreliable, the unit reverts to fail-safe mode.

### Fail-safe mode

In fail-safe mode, compressor operation maybe limited below a user selected ambient temperature. Condenser fan operation is controlled by ambient temperature and compressor operation. If the saturated liquid line temperature is not reliable, one condenser fan is energized for every compressor

that energizes, and the variable speed condenser fan runs at 100%.

When the saturated liquid line temperature becomes reliable, the unit reverts to saturated liquid line temperature control.

### Low ambient mode

This functionality is only available during saturated liquid line temperature control. It is automatically enabled on a circuit with a modulating condenser fan.

When low ambient mode is NOT enabled on a circuit, the lower range of the OAT cooling enable setpoint is 45.0°F.

When low ambient mode IS enabled on a circuit, the lower range of the OAT cooling enable setpoint is -10.0°F.

Low ambient mode cannot be automatically enabled on a circuit unless there is a variable speed condenser fan and liquid line pressure sensor installed on that circuit.

## Heating system

The controller supports multiple heating types including electric heat (staged, modulated), gas heat (staged, modulated), and a hydronic heating coil. The supported heating-related features include: warm-up, discharge air (DA) tempering, load shedding (electric heat), and runtime equalization. If the DAT is lower than the DAT setpoint, the heating demand increases and a heating stage is energized. If the DAT is greater than the DAT setpoint, the heating demand decreases and a heating stage is de-energized.

### Electric heat

The application supports up to ten stages of electric heat as well as modulated electric heat.

### Staged electric heat

If the DAT is lower than the DAT setpoint, the heating demand increases and a heating stage is energized. If the DAT is greater than the DAT setpoint, the heating demand decreases and a heating stage is de-energized.

### Modulating electric heat

If the DAT is lower than the DAT heating setpoint, the heating demand increases. If the DAT is greater than the DAT heating setpoint, the heating demand decreases. The modulating heating stage is connected to a SCR controller. Additional stages are sequenced ON and OFF while the SCR stage automatically fills the gap between the step-controlled stages, providing full proportional control

over the entire heater range. Both the SCR stage and the step-controlled stages are controlled by the heating demand. The modulating stage is the first ON and last OFF.

### Runtime equalization

Runtime equalization only applies to equally sized, non-modulating heating stages. The modulating stage is first ON and last OFF. The controller records the number of starts and runtime statistics for each stage of electric heat.

At the initiation of each heating demand, the stage with the lowest total runtime energizes first. When runtime is equal, the staging is in numerical order. The stage with the next lowest total runtime energizes next and so on. At the termination of heating demand, the stages with the highest runtime stage OFF in reverse order.

### Gas heating

The application supports up to six stages in three furnace modules. The concept behind the staged and modulating furnace options is to offer multiple furnace modules, with each module being its own self-contained, fully functioning furnace.

#### Staged gas heat

If the DAT is lower than the DAT heating setpoint, the staged heating demand increases. If the DAT is greater than the heating setpoint, the staged heating demand decreases. The gas heat modules are energized in response to the heating demand. Each gas heat module has a low fire and a high fire mode, which are individually energized in response to the heating demand. Low fire is always energized prior to high fire.

#### Modulating gas heat

To accomplish this, one furnace module is adapted for modulation. The selected furnace module is started and modulated, while the other ON/OFF furnace modules are staged, which allows a much broader modulation range. If the DAT is lower than the DAT heating setpoint, the heating demand increases. If the DAT is greater than the DAT heating setpoint, the heating demand decreases. Each gas heat module has a low fire and a high fire mode, which are individually energized in response to the heating demand. Low fire is always energized prior to high fire.

### Modulating hydronic heating coil

If the DAT is lower than the DAT heating setpoint, the heating valve modulates open. If the DAT is greater than the DAT heating setpoint, the heating valve modulates closed. The application setup of

either direct or reverse action allows support for either normally open or normally closed valves.

### Freezestat alarm

The application supports a freezestat input that is normally closed. The input opens if:

- the OAT is greater than 40.0°F (adjustable), no action is taken and the unit operates normally.
- the OAT is 40.0°F or less (adjustable), the hot water valve opens 100%, the supply fan de-energizes, the economizer OA damper fully closes, and all other fans de-energize.

The control returns to normal if either

- Freezestat input closes
- the OAT rises above 40.0°F (adjustable).

### Discharge air tempering

When the discharge air tempering is enabled, the unit must be in fan only or cooling mode when the OAT being brought in to ventilate the space causes the DAT to decrease below the DAT tempering setpoint. The air must be heated to prevent low temperature air from being delivered to the space. Discharge air tempering is available on both staged and modulated heating types. The compressors cannot start when discharge air tempering is active.

### Economizer

When the economizer is installed, economizer suitability is true, and there is a call for cooling, then the controller modulates the OA damper between the minimum position and 100% to maintain the MAT to the operating cooling DAT setpoint. Economizer suitability is determined based on the changeover option selected and the available sensors. If the economizer is unable to meet cooling demand after the OA damper has been 100% open for a period of time, the unit controller allows mechanical cooling to operate. When economizer and mechanical cooling are both operating, the OA damper is 100% open.

### Changeover method

The unit can be equipped with one of three types of optional economizers: dry bulb, single enthalpy, or dual enthalpy. When the economizer selection variable is set to auto (default), the unit controller selects which economizer method to use based on which temperature and humidity sensors are present and reliable (see [Table 201](#)).

**Table 201: Free cooling sensor requirements**

	OAT	OAH	RAT	RAH
Dry bulb	X			
Single enthalpy	X	X		
Dual enthalpy	X	X	X	X

The order of economizer selection is dual enthalpy (all sensors reliable), single enthalpy (only OA sensors reliable), and dry bulb (only OAT sensor). The user can also manually select the economizer type when all required sensors are available. If economizer cooling alone is insufficient for the cooling load, the controller stages up compressors, one at a time, to meet demand.

### Dry bulb

With the dry bulb economizer, the controller monitors the OAT only and compares it to a reference temperature setting. Outside air is deemed suitable for economizing when the OAT is less than the reference temperature setting. This method of economizing is effective, but it is prone to some changeover inefficiencies since it is based on sensible temperatures only and does not take outside air moisture content into consideration.

### Single enthalpy

With the optional single enthalpy economizer, the controller monitors the OA enthalpy in addition to the OAT and compares it to a reference enthalpy setting and a reference temperature setting. Outside air is deemed suitable for economizing when the OA enthalpy is determined to be less than the reference enthalpy setting and the OAT is less than the reference temperature setting. This method of economizing allows the reference temperature setting to be set higher than the dry bulb economizer and is consequently a more efficient rooftop economizer.

### Dual enthalpy

With the optional dual enthalpy economizer, the controller monitors and compares the OA and RA enthalpies in addition to comparing the OAT to the reference temperature setting. Outside air is deemed suitable for economizing when the OA enthalpy is determined to be less than the RA enthalpy and the OAT is less than the reference temperature setting. This method of economizing is the most accurate and provides the highest degree of energy efficiency for a rooftop economizer.

### Auto

Auto selects the changeover method based on which sensors are present and reliable. If the OAT, RAT, OA humidity, and RA humidity values are reliable, then the dual enthalpy changeover method is used. If either of the RAT or RA humidity

sensors is unreliable, then the single enthalpy changeover method is used. If the OA humidity sensor is unreliable, then the dry bulb changeover method is used.

**Table 202: Manufacturer fault detection & diagnostics (FDD)**

Manufacturer fault	Description
Economizer - damper not modulating	Economizer damper actuator is inoperable or not responding to commands.
Economizer - not econ when available	Conditions are available for economizer operation but the unit does not use outside air for cooling.
Economizer - econ when not available	Conditions are not available for economizer operation but the unit uses outside air for cooling.
Economizer - excess outside air	Economizer damper is open greater than commanded position.

### Fault detection and diagnostics (FDD)

As required per 2016 California Title 24 and ASHRAE 90.1-2019, the fault detection and diagnostics (FDD) system provides the alarms stated in [Table 202](#).

### ERW

The ERW can run in both cooling and heating modes. In cooling mode, if the conditions are suitable for economizing, the ERW disables, and the bypass dampers fully open.

The ERW enables when the absolute value of the difference between the return air and the outside air is greater than the energy recovery setpoint. If the OA and RA humidity values are reliable, then enthalpy is compared; other-wise dry bulb temperature is compared.

When the ERW stops for extended periods, it energizes briefly for cleaning and blocking protection.

### Single speed ERW

When enabled, the ERW runs at full speed and the ERW bypass dampers fully close. When the exhaust air temperature (EAT) drops below the energy recovery low limit setpoint, the ERW bypass dampers fully open to bypass the ERW.

### Variable speed ERW

When enabled, the ERW runs at full speed and the ERW bypass dampers fully close. When the EAT drops below the energy recovery low limit setpoint, the ERW slows to maintain a minimum EAT to prevent freezing. If the minimum speed does not maintain the temperature setpoint, the bypass dampers fully open to bypass the ERW.

# Ventilation

## Minimum OA damper reset

### Fixed minimum

When the control is in the occupied mode and the fan output energizes, the OA damper is positioned to the minimum position setpoint (adjustable) unless another function commands it open or closed. When the control is in the unoccupied mode, the minimum OA position is zero.

### Supply fan speed

When the control is in the occupied mode, the fan output energizes, and the output reaches 100%, the OA damper position is the damper\_min\_pos\_high\_speed\_fan setpoint. When the VFD output reaches 50% (adjustable) or less, the OA damper position is the damper\_min\_pos\_low\_speed\_fan setpoint. When the VFD output is between 50–100% (adjustable), the OA damper positions proportionally between damper\_min\_pos\_high\_speed\_fan setpoint and damper\_min\_pos\_low\_speed\_fan setpoint.

- ① **Note:** Supply fan speed minimum OA damper reset is not available when demand control ventilation (DCV) is enabled.

### Outside airflow measurement

This control sequence provides for the dynamic determination of the minimum damper position that meets the ASHRAE building ventilation standards. If the outside airflow input is not reliable, then the damper is positioned based upon the default minimum position.

When the fresh air intake value falls below the fresh air intake setpoint, the OA damper position increases above its minimum position until the fresh air intake value equals the fresh air intake setpoint.

When the fresh air intake value rises above the fresh air intake setpoint, the OA damper position decreases until the fresh air intake value equals the fresh air intake setpoint or it reaches minimum position setpoint.

When DCV is enabled on a unit with an outdoor airflow measurement station installed, the fresh air intake setpoint resets upwards until the CO<sub>2</sub> level falls below the DCV setpoint.

- ① **Note:** The low ambient minimum position may force the damper position below the current setpoint and disable the air monitoring station reset.

### External control

The OA damper is controlled directly by a third party (communication or voltage signal). External control takes priority over all other damper control except unit protection.

### Low MAT limiting

When the control is in the occupied mode, the economizer is not active, the fan output is energized, and MAT is below the MAT cooling limit, the damper begins closing. When the MAT is equal to or above the MAT cooling limit, it exits the low MAT limiting mode.

### Demand control ventilation (DCV)

If optional CO<sub>2</sub> sensors are connected to the unit, the controller can reset the minimum OA damper position based on demand. The controller has built-in sequences for indoor CO<sub>2</sub> and comparative CO<sub>2</sub>. Demand ventilation remains active as long as the unit is in the occupied mode of operation.

### Indoor CO<sub>2</sub>

The controller monitors the CO<sub>2</sub> level within the building. If the CO<sub>2</sub> level rises above the CO<sub>2</sub> setpoint, the controller temporarily increases the minimum OA damper position or minimum outside airflow rate to increase ventilation. If the CO<sub>2</sub> level drops below the CO<sub>2</sub> setpoint, the controller decreases the minimum OA damper position or minimum outside airflow rate to decrease ventilation.

### Comparative CO<sub>2</sub>

If differential DCV is enabled and the outdoor air CO<sub>2</sub> level is greater than or equal to the indoor air CO<sub>2</sub> level by more than the demand ventilation differential setpoint, then the OA damper is overridden closed regardless of economizer suitability. Otherwise, the indoor CO<sub>2</sub> sequence is followed.

### Pre-occupancy purge

When the unit is in internal schedule, if pre-occupancy purge is enabled, effective occupancy is unoccupied, the MAT reading is reliable, and the damper is not controlled by higher-priority logic, then pre-occupancy purge mode initiates immediately when the time until occupancy equals the pre-occupancy purge time. Pre-occupancy purge runs until the pre-occupancy purge timer expires or if any of the entry conditions required for pre-occupancy purge mode are violated.

Once in pre-occupancy purge mode, the VAV heat command relay turns on and the system continues to monitor the MAT. If MAT falls below MAT cooling

limit, the system limits the outdoor air damper position until the MAT rises above MAT cooling limit. If the outdoor air damper fully opens, the system resumes regular pre-occupancy purge.

If using an indoor CO<sub>2</sub> sensor and low CO<sub>2</sub> control point is satisfied, then the mode terminates.

## Continuous ventilation

When enabled, the supply fan runs continuously during occupied mode, even when no heating or cooling is required. When continuous ventilation is disabled, the supply fan cycles OFF when no heating or cooling is required.

## Smoke control

If smoke control mode is in one of its active modes, the OA damper sets to 0% or 100%. If smoke control mode is in purge or pressurization mode, the OA damper is 100%. If smoke control mode is in de-pressurization, the OA damper is 0%.

The smoke control sequences are used whenever the safety binary inputs turn ON. It must be noted that the smoke control sequences are not normal operation for rooftop units and are only utilized when smoke or other airborne contaminants must be quickly removed from the conditioned space.

Whenever a smoke control sequence starts, all normal heating and cooling functions stop regardless of the control inputs. This includes all running compressors, condenser fans, heat stages, heating valves, and furnaces.

There are three safety binary inputs available on the customer terminal board. Each input is assigned one of the three sequences. This makes it possible to start and stop any of the three sequences at any time because there are three inputs available for the three sequences. To avoid problems when more than one input is active at the same time, each input has a priority. The sequence assigned to the active input with the highest priority is used over sequences assigned to inputs with a lower priority.

When either one of the safety input mode 1, 2, or 3 is ON, the smoke control mode is assigned one of the following states according to the binary input priorities and the sequence settings:

- ① **Note:** Johnson Controls Rooftop Units offer auxiliary smoke control points that are available for smoke purge, pressurization, and de-pressurization sequences. These sequences and functions are not part of a listed UL 864

UUKL Smoke Control System, nor are they intended to be a replacement for a listed UL 864 UUKL Smoke Control System. Johnson Controls does offer options for listed UL 864 Smoke Control Systems for example:

a) Metasys Release 8.1 UL cUL 864 10th Ed. UUKL / ORD-C100-13 UUKLC Smoke Control System; and

b) Simplex 4100ES Fire Control Units (Addressable Fire Detection and Control Basic Panel Modules and Accessories) which are listed to UL 864, Fire Detection and Control (UOJZ), Smoke Control Service (UUKL), and Releasing Device Service (SYZV).

Only listed smoke control equipment complying with UL 864 is typically considered acceptable to comply with the associated Sections of the Building Code, Mechanical Code and ANSI NFPA 92 / 92A / 92B requirements, and are intended to perform specific functions related to Smoke Control Systems. If a listed UL 864 Smoke Control System is required, please contact Johnson Controls for further information.

## Depressurize

The depressurize mode evacuates, or negatively pressurizes, the building or space to draw air through the walls from adjacent spaces or outside the building envelope. When this sequence starts, the following occurs:

- Sets the supply fan output to OFF.
- Starts the return fan (exhaust fan output) if not already ON.
- Sets exhaust and return fan VFD to 100%.
- Sets OA damper position to 0%.
- Sets RA damper position to 100%.
- Sets EA damper position to 100%.

## Pressurization

The pressurization mode pressurizes the building or space to force the air inside the space through the walls to adjacent spaces or outside the building envelope. When this sequence starts, the following occurs:

- Sets supply fan output to ON.
- If the unit type is MZVAV, the supply fan VFD speed maintains the active duct pressure setpoint and the VAV heat command relay turns ON.
- If the unit type is SZVAV, it sets the supply fan VFD speed to 100%.

- Sets exhaust fan output to OFF.
- Sets return fan output to OFF.
- Sets exhaust and return fan VFD to 0%.
- Sets OA damper position to 100%.
- Sets RA damper position to 0%.
- Sets EA damper position to 0%.

### Purge

The purge mode displaces the air inside the space with fresh outside air. When this sequence starts, the following occurs:

- Sets supply fan output to ON.
- If the unit type is MZVAV, the supply fan VFD speed maintains the active duct pressure setpoint and the VAV heat command relay turns ON.
- If unit type is SZVAV, it sets the supply fan VFD speed to 100%.
- Starts the return fan (exhaust fan output) if not already ON.
- Sets exhaust and return fan VFD to 100%.
- Sets OA damper position to 100%.
- Sets RA damper position to 0%.
- Sets EA damper position to 100%.

## Humidity control

### Humidity sensor

The controller compares the humidity against a setpoint to determine whether to place the unit in dehumidification, humidification, or temperature control only mode. Selectable humidity sensors are zone, return, or external control (BAS communication).

### Dehumidification

#### Modulating hot gas reheat (HGRH)

When dehumidification is enabled, the unit enters dehumidification mode if the humidity sensor rises above the dehumidification setpoint while the unit is in cooling or satisfied mode and the outside air temperature is greater than 55.0°F. The compressors are controlled based on humidity and the reheat device is controlled based on temperature. It also allows for dehumidification when the system is in mechanical cooling or when temperature requirements are satisfied.

When humidity requirements are satisfied, the HGRH status is off-idle and the HGRH valve is closed.

When HGRH status is ON, the staging of compressors is controlled so that the air leaving

the evaporator coil is controlled to an evaporator temperature setpoint. This ensures that water condenses and is removed from the air. The HGRH valve is then modulated so that it reheats the discharge air to the HGRH temperature setpoint.

While the system is in mechanical cooling, the HGRH temperature setpoint is equal to the operational cooling DAT setpoint. This is necessary because the compressors can be controlled to an evaporator temperature setpoint lower than the operational cooling DAT setpoint to remove additional moisture content from the air. This strategy allows humidity to be removed from the air while attempting to maintain normal cooling DATs.

While the system is satisfied, the HGRH valve is controlled so that the HGRH temperature setpoint resets between the operational cooling DAT setpoint and the occupied cooling setpoint. This strategy attempts to remove humidity from the air without affecting the temperature of the space.

The controller uses the humidity sensor as the basis for the evaporator temperature setpoint. When the humidity first rises above setpoint, the evaporator temperature setpoint is equal to the low cooling DAT setpoint. As humidity continues to rise, the evaporator temperature setpoint is lowered to remove additional moisture from the air.

If the unit enters heating mode or the OAT falls below 54.0°F, dehumidification mode ends regardless of humidity.

A zone temperature sensor must be installed for dehumidification during unoccupied mode. Unoccupied dehumidification is not allowed when only a return air temperature sensor is installed.

### HGRH bleed valve

The HGRH bleed valve is a solenoid valve that connects the HGRH coil to the suction line. The purpose of the bleed valve is to bleed off any remaining or trapped liquid in the HGRH coil when dehumidification mode is not active. When the unit enters HGRH ON-normal command, the bleed valve opens. When the HGRH transitions to off-idle mode and after a 5-minute delay, the bleed valve closes.

### Humidification output

The unit is placed in humidification mode, if the humidity sensor falls below the humidification setpoint and the unit is not in cooling mode. The humidifier is enabled, and the humidifier valve modulates to maintain the humidity setpoint as sensed by the humidity sensor. A humidity high limit overrides the output if necessary, to prevent the DA humidity from exceeding the DA humidity high limit setpoint. Humidification is not allowed in cooling mode.

## Twining

The application of having two or more separate rooftop units tied into one common main duct trunk line is known as twinning. The application is compatible with BACnet. The twinning process allows for redundancy with the cooling or heating load. All twinned units operate concurrently and are not sequenced based on the cooling or heating load. It allows for the user to design the system in an N+1 arrangement, in which three units are sized to handle the load and the fourth is available as a backup. The user is then able to shut down one of the running units and enable the backup via the BAS.

Each rooftop unit requires an isolation damper with an end switch to ensure the damper is fully open before the supply fan can start. Each rooftop unit in a twinning application also requires its own duct static pressure sensor to allow the rooftop units to run independently if one or more units are shut down for maintenance or BAS communication is lost. Each unit has a manual reset high duct pressure switch installed to prevent over pressurization of the duct.

In a twinning system, several features are synchronized while others can operate independently. The method used to synchronize these features is for each twinned unit in the group to broadcast the key values so it can be used by the other rooftop units in the group. The approach is referred to as independent twinning.

The idea is that if each unit has the exact same values, then each rooftop unit can execute the exact same control algorithm. This has the advantage of being more robust to communication errors or sensor failures and less complex than a manager and subordinate unit arrangement. If one unit fails or is manually shut down, the remaining units continue to run without interruption. In the manager and subordinate unit arrangement, if the manager unit disables, the failover logic to a different manager is more complicated and may result in a disruption in the system. Independent twinning prevents such disruptions or failures in the system.

The synchronized features include supply fan control, economizer suitability, occupancy, demand control ventilation, exhaust fan control, and smoke control.

The supply fan control must be synchronized to maintain DA static pressure between all units serving the same duct. This requires all reliable DA static pressure values from the rooftop units to be averaged before passing to the proportional-integral-derivative (PID). The static pressure setpoint must also be synchronized, and any change

to one setpoint must be shared with the other rooftop units. This allows the PID in each rooftop unit to calculate the same output value and run all the supply fans at the same speed.

During start-up of a previously shutdown rooftop unit, the supply fan speed slowly ramps up until it matches the fan speeds of the rooftop units currently in operation. When the additional rooftop unit begins ramping, the static pressure increases, causing the other rooftop unit fans speeds to slow down to reach setpoint. Once the rooftop unit fan speed matches the existing rooftop units, it releases into control.

The economizer suitability must also be synchronized to allow all the units to use the OA damper for free cooling when available. This also avoids a situation where one unit is operating in economizer mode while another unit operates in mechanical cooling mode.

The occupancy for the twinned units must also be synchronized to allow all units to switch between occupied and unoccupied modes simultaneously. This includes the occupancy schedule and warm-up/cool down if enabled.

The DCV is synchronized to allow the OA damper minimum position to be reset equally between the units. This requires the indoor CO<sub>2</sub> values from the units to be shared and the maximum to be passed to the reset logic to ensure sufficient outside air is brought in for proper ventilation. The indoor CO<sub>2</sub> setpoint also synchronizes so the reset calculation is the same across all units.

The exhaust fan system must be synchronized to allow for proper building pressurization. This requires the building static pressure values from each unit to be averaged before passing to the PID. The building static pressure setpoint also synchronizes, and any change to one setpoint must be shared with the other rooftop units.

The smoke control feature is synchronized to ensure all units properly switch between the purge, pressurization, or depressurization modes. This requires the three safety binary inputs and their priorities on each unit to be shared so if any binary input is ON, all twinned units respond the same way.

The temperature control, return fan systems, and safety shutdowns can operate individually on each unit. The temperature setpoints synchronize to allow for similar operation between the units. The temperature loops are not required to be as tightly coupled as the supply and exhaust fan systems.

The twinning feature also has the following additional requirements:

- Customer terminal board required for twinning application

- VAV system types only
- All units must be the same tonnage
- Fan systems operate together based upon average duct static pressure
- External control not supported
- The same static pressure probe can be connected to all discharge pressure transducers
- The same static pressure probe can be connected to all building pressure transducers
- A supervisory device must be installed on the network
- Maximum of 4 twinned units on a single MSTP bus. Units can be twinned as one set of four or two sets of two
- Maximum of forty units are twinned on a BACnet IP trunk
- BACnet MSTP or BACnet IP only
- Twinning is not possible on wireless field bus networks or with RTU's that interface to the BAS using Modbus or N2
- Isolation dampers with end switches must be installed on each twinned unit.

## Unit protection

The unit utilizes several system safeties to ensure unit protection, including low voltage, compressor system status monitoring, low and high pressure cutout monitoring, suction temperature monitoring, freeze protection, fan overload, shutdown, furnace limit, and MAT low limit.

Conditions that cause the unit to be locked out require user intervention. Refrigeration fault lockouts cannot be reset from the BAS. All other fault lockouts can be reset from network input or local UI.

## Unit shutdown

Any time the normally closed contact opens, all relay outputs immediately de-energize and the unit shuts down. An alarm generates and displays on the unit controller.

## Unit test

### Start-up wizard

Field service technicians use the start-up wizard function to complete the unit configuration and start-up. It is a sequence of automatic self-tests and manually verified tests that are required for start-up documentation. For each test, a PASS/FAIL, date/time stamp, and relevant system data are recorded. After the testing sequence completes, a report with

the recorded results is stored and downloadable via USB.

### Air balancing wizard

The air balancing wizard is a grouping of configuration screens used for testing and calibrating airflow measuring stations, overriding damper positions, overriding fan speeds, and other functions to assist service technicians and air balancers.

### Commissioning mode

Commissioning mode is a function used for manually operating the unit during a service call or commissioning demonstration. It allows for the unit components to be operated individually. The unit must not be operated in this mode for an extended period, therefore commissioning mode terminates automatically after 60 minutes unless extended at the local UI for another 60 minutes.

Cooling and heating is disabled unless the supply fan status is proven. Unit protection and safeties remain active and logged during commissioning mode.

# Weights and dimensions

## Weights

Figure 13: Standard cabinet unit sections

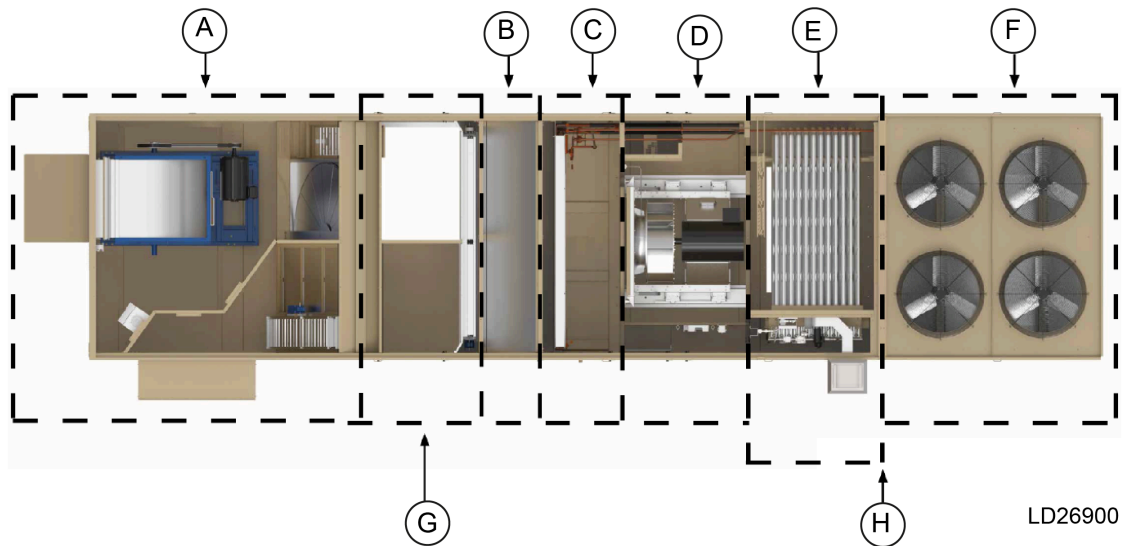

Table 203: Standard cabinet unit sections

Item	Description
A	Economizer cabinet with or without ERW cabinet
B	Draw-through filter cabinet
C	Evaporator cabinet
D	Supply fan cabinet
E	Heat and discharge cabinet <sup>4</sup>
F	Condenser fan cabinet with compressors
G	Pre-evaporator blank cabinet, air blender cabinet: between economizer and draw-through filter
H	Small post-evaporator blank cabinet, large post-evaporator blank cabinet, discharge plenum cabinet: upstream of condenser section

Table 204: Weight data (lb)

Model	25 ton	30 ton	40 ton	50 ton	60 ton	70 ton	80 ton
<b>Base unit section weights - standard cabinet, see Figure 13</b>							
Economizer cabinet <sup>1</sup>	830	830	906	906	919	919	919
Energy recovery wheel cabinet	748	748	800	800	1869	2047	2047
Pre-evaporator blank cabinet <sup>2</sup>	548	548	587	587	461	461	461
Draw-through filter cabinet - vertical filter, 4 in.	98	98	105	105	203	203	203
Draw-through filter cabinet - angle, rigid, bag	264	264	282	282	386	386	386
Evaporator cabinet	303	303	324	324	487	1021	1021
Supply fan cabinet	440	440	471	471	-	-	-
Supply fan cabinet (55 in. section) <sup>16</sup>	-	-	-	-	1368	1368	1368
Supply fan cabinet (74 in. section) <sup>16</sup>	-	-	-	-	1579	1579	1579
Heat section cabinet (requires discharge plenum) <sup>3</sup>	522	522	559	559	1113	1113	1113
Heat with discharge through heat section <sup>4</sup>	668	668	732	732	955	955	955
Small post-evaporator blank cabinet <sup>5</sup>	440	440	471	471	423	423	423
Large post-evaporator blank cabinet <sup>6</sup>	914	914	978	978	651	651	651
Discharge plenum cabinet <sup>7</sup>	501	501	554	554	606	686	686
<b>Direct drive plenum (DDP) supply fan components <sup>8</sup></b>							
Supply fan and 5 HP 200-208 V ODP	415	415	-	-	598	598	598
Supply fan and 7.5 HP 200-208 V ODP	463	463	-	-	725	725	725
Supply fan and 10 HP 200-208 V ODP	464	464	600	600	757	757	757
Supply fan and 15 HP 200-208 V ODP	563	563	699	699	968	968	968
Supply fan and 20 HP 200-208 V ODP	585	585	721	721	1076	1076	1076

**Table 204: Weight data (lb)**

Model	25 ton	30 ton	40 ton	50 ton	60 ton	70 ton	80 ton
Supply fan and 25 HP 200-208 V ODP	688	688	823	823	1294	1294	1294
Supply fan and 30 HP 200-208 V ODP	-	-	869	869	1436	1436	1436
Supply fan and 40 HP 200-208 V ODP	-	-	876	876	1463	1463	1463
Supply fan and 50 HP 200-208 V ODP	-	-	979	979	-	-	-
Supply fan and 5 HP 200-208 V TEFC	417	417	-	-	620	620	620
Supply fan and 7.5 HP 200-208 V TEFC	474	474	-	-	767	767	767
Supply fan and 10 HP 200-208 V TEFC	506	506	641	641	831	831	831
Supply fan and 15 HP 200-208 V TEFC	605	605	740	740	1044	1044	1044
Supply fan and 20 HP 200-208 V TEFC	639	639	775	775	1174	1174	1174
Supply fan and 25 HP 200-208 V TEFC	741	741	877	877	1392	1392	1392
Supply fan and 30 HP 200-208 V TEFC	-	-	941	941	1566	1566	1566
Supply fan and 40 HP 200-208 V TEFC	-	-	1096	1096	1736	1736	1736
Supply fan and 50 HP 200-208 V TEFC	-	-	1230	1230	-	-	-
Supply fan and 5 HP 230/460 V ODP	415	415	-	-	598	598	598
Supply fan and 7.5 HP 230/460 V ODP	463	463	-	-	725	725	725
Supply fan and 10 HP 230/460 V ODP	464	464	600	600	757	757	757
Supply fan and 15 HP 230/460 V ODP	563	563	699	699	968	968	968
Supply fan and 20 HP 230/460 V ODP	585	585	721	721	1076	1076	1076
Supply fan and 25 HP 230/460 V ODP	688	688	823	823	1294	1294	1294
Supply fan and 30 HP 230/460 V ODP	-	-	869	869	1436	1436	1436
Supply fan and 40 HP 230/460 V ODP	-	-	876	876	1463	1463	1463
Supply fan and 50 HP 230/460 V ODP	-	-	979	979	-	-	-
Supply fan and 5 HP 230/460 V TEFC	417	417	-	-	620	620	620
Supply fan and 7.5 HP 230/460 V TEFC	474	474	-	-	767	767	767
Supply fan and 10 HP 230/460 V TEFC	506	506	641	641	831	831	831
Supply fan and 15 HP 230/460 V TEFC	605	605	740	740	1044	1044	1044
Supply fan and 20 HP 230/460 V TEFC	639	639	775	775	1174	1174	1174
Supply fan and 25 HP 230/460 V TEFC	741	741	877	877	1392	1392	1392
Supply fan and 30 HP 230/460 V TEFC	-	-	941	941	1566	1566	1566
Supply fan and 40 HP 230/460 V TEFC	-	-	1096	1096	1736	1736	1736
Supply fan and 50 HP 230/460 V TEFC	-	-	1230	1230	-	-	-
Supply fan and 5 HP 575 V ODP	426	426	-	-	611	611	611
Supply fan and 7.5 HP 575 V ODP	457	457	-	-	717	717	717
Supply fan and 10 HP 575 V ODP	474	474	610	610	743	743	743
Supply fan and 15 HP 575 V ODP	582	582	717	717	957	957	957
Supply fan and 20 HP 575 V ODP	585	585	721	721	1001	1001	1001
Supply fan and 25 HP 575 V ODP	688	688	823	823	1272	1272	1272
Supply fan and 30 HP 575 V ODP	-	-	852	852	1360	1360	1360
Supply fan and 40 HP 575 V ODP	-	-	876	876	1463	1463	1463
Supply fan and 50 HP 575 V ODP	-	-	949	949	-	-	-
Supply fan and 5 HP 575 V TEFC	427	427	-	-	633	633	633
Supply fan and 7.5 HP 575 V TEFC	475	475	-	-	759	759	759
Supply fan and 10 HP 575 V TEFC	506	506	641	641	817	817	817
Supply fan and 15 HP 575 V TEFC	605	605	740	740	1033	1033	1033
Supply fan and 20 HP 575 V TEFC	658	658	793	793	1099	1099	1099
Supply fan and 25 HP 575 V TEFC	762	762	898	898	1370	1370	1370
Supply fan and 30 HP 575 V TEFC	-	-	941	941	1490	1490	1490
Supply fan and 40 HP 575 V TEFC	-	-	1096	1096	1736	1736	1736
Supply fan and 50 HP 575 V TEFC	-	-	1155	1155	-	-	-
<b>Energy recovery wheel (ERW)</b>							
Low CFM	929	929	1181	1181	653	681	681
High CFM	965	965	1228	1228	868	1013	1013
<b>Exhaust, return, and outside air economizer section <sup>9</sup></b>							
Economizer - no fan	378	378	494	494	612	628	628
Economizer with exhaust fan	883	883	1050	1050	1661	1678	1678
Economizer with return fan	1055	1055	1289	1289	692	708	708
<b>Motor for exhaust and return fan<sup>10</sup></b>							
Vertical direct driven return fan and 7.5 HP motor 208-230/460 V ODP	-	-	-	-	1382	1406	1406
Vertical direct driven return fan and 10 HP motor 208-230/460 V ODP	-	-	-	-	1451	1475	1475
Vertical direct driven return fan and 15 HP motor 208-230/460 V ODP	-	-	-	-	1493	1517	1517

**Table 204: Weight data (lb)**

Model	25 ton	30 ton	40 ton	50 ton	60 ton	70 ton	80 ton
Vertical direct driven return fan and 20 HP motor 208-230/460 V ODP	-	-	-	-	1551	1575	1575
Vertical direct driven return fan and 25 HP motor 208-230/460 V ODP	-	-	-	-	1511	1535	1535
Vertical direct driven return fan and 30 HP motor 208-230/460 V ODP	-	-	-	-	1613	1637	1637
Vertical direct driven return fan and 40 HP motor 208-230/460 V ODP	-	-	-	-	1792	1816	1816
Vertical direct driven return fan and 7.5 HP motor 208-230/460 V TEFC	-	-	-	-	1437	1461	1461
Vertical direct driven return fan and 10 HP motor 208-230/460 V TEFC	-	-	-	-	1462	1486	1486
Vertical direct driven return fan and 15 HP motor 208-230/460 V TEFC	-	-	-	-	1656	1680	1680
Vertical direct driven return fan and 20 HP motor 208-230/460 V TEFC	-	-	-	-	1679	1703	1703
Vertical direct driven return fan and 25 HP motor 208-230/460 V TEFC	-	-	-	-	1669	1693	1693
Vertical direct driven return fan and 30 HP motor 208-230/460 V TEFC	-	-	-	-	1729	1753	1753
Vertical direct driven return fan and 40 HP motor 208-230/460 V TEFC	-	-	-	-	1894	1918	1918
Vertical direct driven return fan and 7.5 HP motor 575 V ODP	-	-	-	-	1379	1403	1403
Vertical direct driven return fan and 10 HP motor 575 V ODP	-	-	-	-	1448	1472	1472
Vertical direct driven return fan and 15 HP motor 575 V ODP	-	-	-	-	1498	1522	1522
Vertical direct driven return fan and 20 HP motor 575 V ODP	-	-	-	-	1523	1547	1547
Vertical direct driven return fan and 25 HP motor 575 V ODP	-	-	-	-	1511	1535	1535
Vertical direct driven return fan and 30 HP motor 575 V ODP	-	-	-	-	1588	1612	1612
Vertical direct driven return fan and 40 HP motor 575 V ODP	-	-	-	-	1767	1791	1791
Vertical direct driven return fan and 7.5 HP motor 575 V TEFC	-	-	-	-	1444	1468	1468
Vertical direct driven return fan and 10 HP motor 575 V TEFC	-	-	-	-	1499	1523	1523
Vertical direct driven return fan and 15 HP motor 575 V TEFC	-	-	-	-	1591	1615	1615
Vertical direct driven return fan and 20 HP motor 575 V TEFC	-	-	-	-	1681	1705	1705
Vertical direct driven return fan and 25 HP motor 575 V TEFC	-	-	-	-	1679	1702	1702
Vertical direct driven return fan and 30 HP motor 575 V TEFC	-	-	-	-	1717	1741	1741
Vertical direct driven return fan and 40 HP motor 575 V TEFC	-	-	-	-	1909	1933	1933
Horizontal direct driven return fan and 7.5 HP motor 208-230/460 V ODP	-	-	-	-	1452	1476	1476
Horizontal direct driven return fan and 10 HP motor 208-230/460 V ODP	-	-	-	-	1521	1545	1545
Horizontal direct driven return fan and 15 HP motor 208-230/460 V ODP	-	-	-	-	1563	1587	1587
Horizontal direct driven return fan and 20 HP motor 208-230/460 V ODP	-	-	-	-	1621	1645	1645
Horizontal direct driven return fan and 25 HP motor 208-230/460 V ODP	-	-	-	-	1581	1605	1605
Horizontal direct driven return fan and 30 HP motor 208-230/460 V ODP	-	-	-	-	1681	1707	1707
Horizontal direct driven return fan and 40 HP motor 208-230/460 V ODP	-	-	-	-	1862	1886	1886
Horizontal direct driven return fan and 7.5 HP motor 208-230/460 V TEFC	-	-	-	-	1507	1531	1531
Horizontal direct driven return fan and 10 HP motor 208-230/460 V TEFC	-	-	-	-	1532	1556	1556
Horizontal direct driven return fan and 15 HP motor 208-230/460 V TEFC	-	-	-	-	1726	1750	1750
Horizontal direct driven return fan and 20 HP motor 208-230/460 V TEFC	-	-	-	-	1749	1773	1773
Horizontal direct driven return fan and 25 HP motor 208-230/460 V TEFC	-	-	-	-	1739	1763	1763
Horizontal direct driven return fan and 30 HP motor 208-230/460 V TEFC	-	-	-	-	1799	1823	1823
Horizontal direct driven return fan and 40 HP motor 208-230/460 V TEFC	-	-	-	-	1964	1988	1988
Horizontal direct driven return fan and 7.5 HP motor 575 V ODP	-	-	-	-	1449	1473	1473
Horizontal direct driven return fan and 10 HP motor 575 V ODP	-	-	-	-	1514	1538	1538

**Table 204: Weight data (lb)**

Model	25 ton	30 ton	40 ton	50 ton	60 ton	70 ton	80 ton
Horizontal direct driven return fan and 15 HP motor 575 V ODP	-	-	-	-	1568	1592	1592
Horizontal direct driven return fan and 20 HP motor 575 V ODP	-	-	-	-	1593	1617	1617
Horizontal direct driven return fan and 25 HP motor 575 V ODP	-	-	-	-	1581	1605	1605
Horizontal direct driven return fan and 30 HP motor 575 V ODP	-	-	-	-	1658	1682	1682
Horizontal direct driven return fan and 40 HP motor 575 V ODP	-	-	-	-	1837	1861	1861
Horizontal direct driven return fan and 7.5 HP motor 575 V TEFC	-	-	-	-	1514	1538	1538
Horizontal direct driven return fan and 10 HP motor 575 V TEFC	-	-	-	-	1569	1593	1593
Horizontal direct driven return fan and 15 HP motor 575 V TEFC	-	-	-	-	1661	1685	1685
Horizontal direct driven return fan and 20 HP motor 575 V TEFC	-	-	-	-	1751	1775	1775
Horizontal direct driven return fan and 25 HP motor 575 V TEFC	-	-	-	-	1749	1773	1773
Horizontal direct driven return fan and 30 HP motor 575 V TEFC	-	-	-	-	1787	1811	1811
Horizontal direct driven return fan and 40 HP motor 575 V TEFC	-	-	-	-	1979	2003	2003
Belt driven exhaust and return fan 3 HP motor 200-208 V ODP	82	82	-	-	-	-	-
Belt driven exhaust and return fan 5 HP motor 200-208 V ODP	88	88	92	92	104	104	104
Belt driven exhaust and return fan 7.5 HP motor 200-208 V ODP	132	132	136	136	142	142	142
Belt driven exhaust and return fan 10 HP motor 200-208 V ODP	133	133	137	137	155	155	155
Belt driven exhaust and return fan 15 HP motor 200-208 V ODP	223	223	227	227	281	281	281
Belt driven exhaust and return fan 20 HP motor 200-208 V ODP	-	-	247	247	314	314	314
Belt driven exhaust and return fan 25 HP motor 200-208 V ODP	-	-	-	-	414	414	414
Belt driven exhaust and return fan 30 HP motor 200-208 V ODP	-	-	-	-	-	467	467
Belt driven exhaust and return fan 40 HP motor 200-208 V ODP	-	-	-	-	-	485	485
Belt driven exhaust and return fan 3 HP motor 200-208 V TEFC	84	84	-	-	-	-	-
Belt driven exhaust and return fan 5 HP motor 200-208 V TEFC	90	90	94	94	113	113	113
Belt driven exhaust and return fan 7.5 HP motor 200-208 V TEFC	142	142	146	146	178	178	178
Belt driven exhaust and return fan 10 HP motor 200-208 V TEFC	171	171	175	175	189	189	189
Belt driven exhaust and return fan 15 HP motor 200-208 V TEFC	261	261	265	265	301	301	301
Belt driven exhaust and return fan 20 HP motor 200-208 V TEFC	-	-	296	296	373	373	373
Belt driven exhaust and return fan 25 HP motor 200-208 V TEFC	-	-	-	-	501	501	501
Belt driven exhaust and return fan 30 HP motor 200-208 V TEFC	-	-	-	-	-	526	526
Belt driven exhaust and return fan 40 HP motor 200-208 V TEFC	-	-	-	-	-	685	685
Belt driven exhaust and return fan 3 HP motor 230/460 V ODP	82	82	-	-	-	-	-
Belt driven exhaust and return fan 5 HP motor 230/460 V ODP	88	88	92	92	104	104	104
Belt driven exhaust and return fan 7.5 HP motor 230/460 V ODP	132	132	136	136	142	142	142
Belt driven exhaust and return fan 10 HP motor 230/460 V ODP	133	133	137	137	155	155	155
Belt driven exhaust and return fan 15 HP motor 230/460 V ODP	223	223	227	227	281	281	281
Belt driven exhaust and return fan 20 HP motor 230/460 V ODP	-	-	247	247	314	314	314
Belt driven exhaust and return fan 25 HP motor 230/460 V ODP	-	-	-	-	414	414	414
Belt driven exhaust and return fan 30 HP motor 230/460 V ODP	-	-	-	-	-	467	467
Belt driven exhaust and return fan 40 HP motor 230/460 V ODP	-	-	-	-	-	485	485
Belt driven exhaust and return fan 3 HP motor 230/460 V TEFC	84	84	-	-	-	-	-
Belt driven exhaust and return fan 5 HP motor 230/460 V TEFC	90	90	94	94	113	113	113
Belt driven exhaust and return fan 7.5 HP motor 230/460 V TEFC	142	142	146	146	178	178	178
Belt driven exhaust and return fan 10 HP motor 230/460 V TEFC	171	171	175	175	189	189	189
Belt driven exhaust and return fan 15 HP motor 230/460 V TEFC	261	261	265	265	301	301	301
Belt driven exhaust and return fan 20 HP motor 230/460 V TEFC	-	-	296	296	373	373	373
Belt driven exhaust and return fan 25 HP motor 230/460 V TEFC	-	-	-	-	501	501	501
Belt driven exhaust and return fan 30 HP motor 230/460 V TEFC	-	-	-	-	-	526	526
Belt driven exhaust and return fan 40 HP motor 230/460 V TEFC	-	-	-	-	-	685	685
Belt driven exhaust and return fan 3 HP motor 575 V ODP	89	89	-	-	-	-	-
Belt driven exhaust and return fan 5 HP motor 575 V ODP	98	98	102	102	117	117	117
Belt driven exhaust and return fan 7.5 HP motor 575 V ODP	126	126	130	130	155	155	155
Belt driven exhaust and return fan 10 HP motor 575 V ODP	142	142	146	146	157	157	157
Belt driven exhaust and return fan 15 HP motor 575 V ODP	240	240	244	244	249	249	249
Belt driven exhaust and return fan 20 HP motor 575 V ODP	-	-	247	247	287	287	287
Belt driven exhaust and return fan 25 HP motor 575 V ODP	-	-	-	-	394	394	394
Belt driven exhaust and return fan 30 HP motor 575 V ODP	-	-	-	-	-	442	442
Belt driven exhaust and return fan 40 HP motor 575 V ODP	-	-	-	-	-	464	464
Belt driven exhaust and return fan 3 HP motor 575 V TEFC	90	90	-	-	-	-	-
Belt driven exhaust and return fan 5 HP motor 575 V TEFC	99	99	103	103	114	114	114
Belt driven exhaust and return fan 7.5 HP motor 575 V TEFC	143	143	147	147	176	176	176
Belt driven exhaust and return fan 10 HP motor 575 V TEFC	171	171	175	175	190	190	190
Belt driven exhaust and return fan 15 HP motor 575 V TEFC	261	261	265	265	295	295	295
Belt driven exhaust and return fan 20 HP motor 575 V TEFC	-	-	313	313	330	330	330
Belt driven exhaust and return fan 25 HP motor 575 V TEFC	-	-	-	-	499	499	499

**Table 204: Weight data (lb)**

Model	25 ton	30 ton	40 ton	50 ton	60 ton	70 ton	80 ton
Belt driven exhaust and return fan 30 HP motor 575 V TEFC	-	-	-	-	-	487	487
Belt driven exhaust and return fan 40 HP motor 575 V TEFC	-	-	-	-	-	639	639
<b>Dual ERW fan</b>							
Dual ERW fan and dual 5 HP motor 208-230/460 V ODP	-	-	-	-	1074	1399	1399
Dual ERW fan and dual 7.5 HP motor 208-230/460 V ODP	-	-	-	-	1143	1340	1340
Dual ERW fan and dual 10 HP motor 208-230/460 V ODP	-	-	-	-	1189	1389	1389
Dual ERW fan and dual 15 HP motor 208-230/460 V ODP	-	-	-	-	1406	1694	1694
Dual ERW fan and dual 20 HP motor 208-230/460 V ODP	-	-	-	-	1470	1758	1758
Dual ERW fan and dual 5 HP motor 208-230/460 V TEFC	-	-	-	-	1092	1269	1269
Dual ERW fan and dual 7.5 HP motor 208-230/460 V TEFC	-	-	-	-	1188	1385	1385
Dual ERW fan and dual 10 HP motor 208-230/460 V TEFC	-	-	-	-	1230	1430	1430
Dual ERW fan and dual 15 HP motor 208-230/460 V TEFC	-	-	-	-	1448	1648	1648
Dual ERW fan and dual 20 HP motor 208-230/460 V TEFC	-	-	-	-	1524	1724	1724
Dual ERW fan and dual 5 HP motor 575 V ODP	-	-	-	-	1050	1247	1247
Dual ERW fan and dual 7.5 HP motor 575 V ODP	-	-	-	-	1146	1343	1343
Dual ERW fan and dual 10 HP motor 575 V ODP	-	-	-	-	1152	1352	1352
Dual ERW fan and dual 15 HP motor 575 V ODP	-	-	-	-	1330	1530	1530
Dual ERW fan and dual 20 HP motor 575 V ODP	-	-	-	-	1406	1606	1606
Dual ERW fan and dual 5 HP motor 575 V TEFC	-	-	-	-	1064	1261	1261
Dual ERW fan and dual 7.5 HP motor 575 V TEFC	-	-	-	-	1188	1385	1385
Dual ERW fan and dual 10 HP motor 575 V TEFC	-	-	-	-	1236	1436	1436
Dual ERW fan and dual 15 HP motor 575 V TEFC	-	-	-	-	1422	1622	1622
Dual ERW fan and dual 20 HP motor 575 V TEFC	-	-	-	-	1488	1688	1688
<b>Motor weights</b>							
3 HP Motor 208-230/460V ODP	82	82	-	-	-	-	-
5 HP Motor 208-230/460V ODP	88	88	92	92	104	104	104
7.5 HP Motor 208-230/460V ODP	132	132	136	136	142	142	142
10 HP Motor 208-230/460V ODP	133	133	137	137	155	155	155
15 HP Motor 208-230/460V ODP	223	223	227	227	281	281	281
20 HP Motor 208-230/460V ODP	-	-	247	247	314	314	314
25 HP Motor 208-230/460V ODP	-	-	-	-	414	414	414
30 HP Motor 208-230/460V ODP	-	-	-	-	-	467	467
40 HP Motor 208-230/460V ODP	-	-	-	-	-	485	485
50 HP Motor 208-230/460V ODP	-	-	-	-	-	-	-
3 HP Motor 208-230/460V TEFC	84	84	-	-	-	-	-
5 HP Motor 208-230/460V TEFC	90	90	94	94	113	113	113
7.5 HP Motor 208-230/460V TEFC	142	142	146	146	178	178	178
10 HP Motor 208-230/460V TEFC	171	171	175	175	189	189	189
15 HP Motor 208-230/460V TEFC	261	261	265	265	301	301	301
20 HP Motor 208-230/460V TEFC	-	-	296	296	373	373	373
25 HP Motor 208-230/460V TEFC	-	-	-	-	501	501	501
30 HP Motor 208-230/460V TEFC	-	-	-	-	-	526	526
40 HP Motor 208-230/460V TEFC	-	-	-	-	-	685	685
50 HP Motor 208-230/460V TEFC	-	-	-	-	-	-	-
3 HP Motor 575V ODP	89	89	-	-	-	-	-
5 HP Motor 575V ODP	98	98	102	102	116.6	116.6	116.6
7.5 HP Motor 575V ODP	126	126	130	130	154.6	154.6	154.6
10 HP Motor 575V ODP	142	142	146	146	156.6	156.6	156.6
15 HP Motor 575V ODP	240	240	244	244	248.5	248.4	248.4
20 HP Motor 575V ODP	-	-	247	247	286.5	286.5	286.5
25 HP Motor 575V ODP	-	-	-	-	394	394	394
30 HP Motor 575V ODP	-	-	-	-	-	442	442
40 HP Motor 575V ODP	-	-	-	-	-	464	464
50 HP Motor 575V ODP	-	-	-	-	-	-	-
3 HP Motor 575V TEFC	90	90	-	-	-	-	-
5 HP Motor 575V TEFC	99	99	103	103	114	114	114
7.5 HP Motor 575V TEFC	143	143	147	147	176	176	176
10 HP Motor 575V TEFC	171	171	175	175	190	190	190
15 HP Motor 575V TEFC	261	261	265	265	295	295	295
20 HP Motor 575V TEFC	-	-	313	313	330	330	330
25 HP Motor 575V TEFC	-	-	-	-	499	499	499
30 HP Motor 575V TEFC	-	-	-	-	-	487	487
40 HP Motor 575V TEFC	-	-	-	-	-	639	639
50 HP Motor 575V TEFC	-	-	-	-	-	-	-

**Table 204: Weight data (lb)**

Model	25 ton	30 ton	40 ton	50 ton	60 ton	70 ton	80 ton
<b>Draw-through filters</b>							
Angled filter rack - 2 in. throwaway filters	112	112	136	136	142	142	142
Angled filter rack - 2 in. MERV 8 filters	118	118	144	144	160	160	160
MERV 15 bag filters with 2 in. pre filters	126	126	167	167	199	199	199
MERV 14 rigid filters with 2 in. pre filters	212	212	303	303	447	447	447
Vertical filter rack - 4 in. MERV 8 filters	73	73	90	90	141	141	141
<b>Final filters - post-evaporator coil</b>							
MERV 15 bag filters with 2 in. pre filters	126	126	167	167	209	209	209
MERV 14 rigid filters with 2 in. pre filters	212	212	303	303	426	426	426
MERV 17 HEPA filters with 2 in. pre filters	405	405	506	506	996	996	996
<b>Gas heat, stage or modulating - aluminized or stainless steel</b>							
250 MBH	233	233	-	-	-	-	-
500 MBH	348	348	361	361	358	358	358
750 MBH	530	530	542	542	-	-	-
1000 MBH	-	-	-	-	610	610	610
1250 MBH	-	-	839	839	-	-	-
1500 MBH	-	-	-	-	860	860	860
<b>Electric heat <sup>11</sup></b>							
Low heat	315	315	420	420	270	270	270
High heat	346	346	462	462	315	315	315
<b>Hot water heat</b>							
Low heat with valves	202	202	224	224	192	192	192
High heat with valves	341	341	267	267	245	245	245
<b>Steam heat</b>							
Low heat with valves	223	223	234	234	185	185	200
High heat with valves	238	238	250	250	241	241	241
<b>Refrigeration system</b>							
Standard efficiency cooling system	1556	1780	2350	2487	2815	4313	4427
High capacity cooling system	1611	1871	2368	2695	2910	4379	4508
High efficiency cooling system	1647	1829	2581	2853	2917	4405	4412
Hot gas reheat (HGRH) coil	35	35	44	44	73	87	87
Louver hail guard	131	131	166	166	249	286	286
<b>Miscellaneous options</b>							
Humidifier	121	121	185	185	112	161	161
Air blender	84	84	132	132	166	185	185
Ultraviolet (UV) lights	45	45	45	45	115	115	115
Sound attenuator	532	532	661	661	1001	1001	1001
Internal lights	35	35	35	35	35	35	35
Smoke detector	2	2	2	2	7	7	7
Transformer <sup>12</sup>	60	60	60	60	60	60	60
Split unit	-	-	-	-	109	47	47
Redundant return fan VFD 7.5-15 HP	-	-	-	-	21	21	21
Redundant return fan VFD 20-25 HP	-	-	-	-	54	54	54
Redundant return fan VFD 30-40 HP	-	-	-	-	79	79	79
Belt guard	6	6	7	7	83	83	83

**Notes:**

- Economizer cabinet weight must be included in all 25 ton to 80 ton units.
- Pre-evaporator blank can be a blank section or include an air blender.
- Heat section cabinet option for any of the following:
  - Top or right discharge
  - Discharge filters, humidifier or sound attenuator, or blank post-evaporator section
  - Requires discharge plenum. Discharge can be bottom, left, right, or top
- Heat and discharge through heat option is used unless any of the following are included:
  - Discharge filters
  - Humidifier, sound attenuator, or blank post-evaporator section
  - Top or right discharge
  - Discharge plenum
- Small post-evaporator blank can contain *blank* or *final filter* or *humidifier* or *sound attenuator*.
- Large post-evaporator blank can contain *blank* or *sound attenuator and final filter* or *sound attenuator and humidifier* or *humidifier or sound attenuator*.
- Discharge plenum is required with all units that are cooling only. Discharge plenum is required on all units with heat section cabinet.
- Supply fan weights include the supply fan, motor, isolators, inlet guards, shaft grounding ring, variable frequency drive (VFD), line reactor, disconnect, and VFD bypass. On 60 ton to 80 ton units, supply fan weights are for both fans and motors.
- Economizer with belt driven exhaust or return fan includes the weight of the fan, isolator, shaft grounding rings, extended lube lines, and inlet guards.

10. For belt driven exhaust or return fan motor includes the weight of the motor, VFD, line reactor, and VFD bypass. For direct driven return fan, weight includes return fan and motor, isolators, inlet guards, shaft grounding ring, VFD, line reactor. Return fan redundant VFD weight included under miscellaneous options.
11. All sizes of electric heat.
12. A transformer is required if convenience outlet, gas heat, lights, or high end display are selected.
13. Roof curb weight is not included with this table.
14. Considering standard cooling unit configuration the Refrigeration system weight includes condenser fan, compressor, piping, condenser coil, refrigerant, wire guards, condenser sheetmetal and evaporator coil.
15. For units that are shipped split please contact your local sales office or use Selection Navigator to get the individual air handler and condenser unit weights.
16. Cooling only units with a no post evaporator blank, a small empty post evaporator blank, a large empty post evaporator blank or a large post evaporator blank equipped with a humidifier or final filter have a 55 in. fan section length, all other units have a 74 in. fan section length.

## Dimensions

**Figure 14: Rooftop unit component locations**

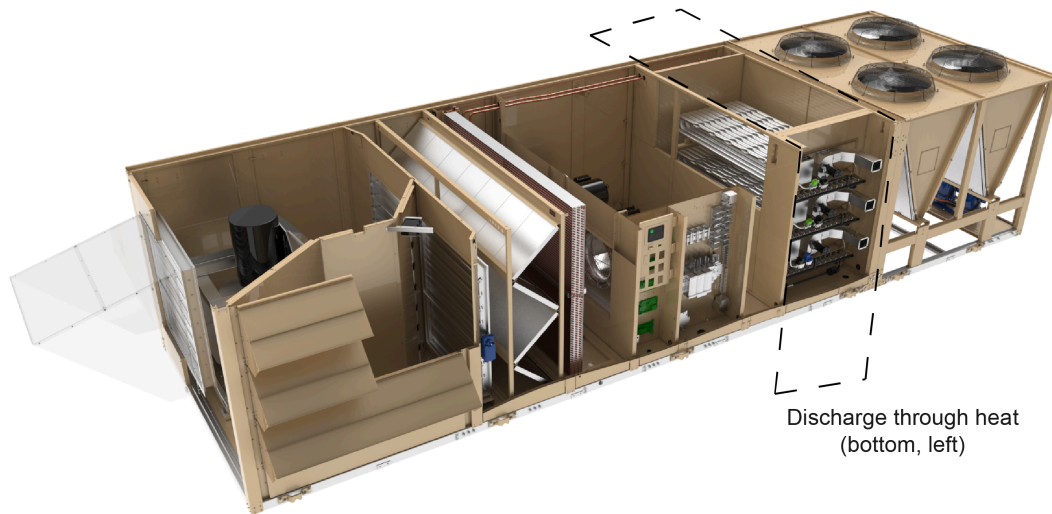

LD30002

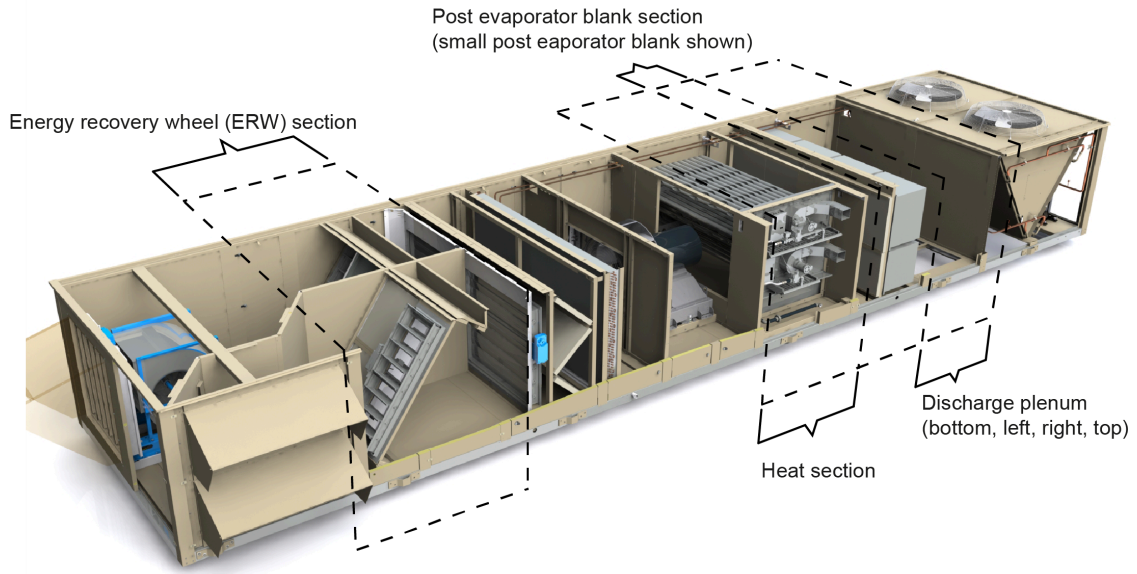

LD27643

Figure 15: 25 ton to 30 ton dimensional drawing

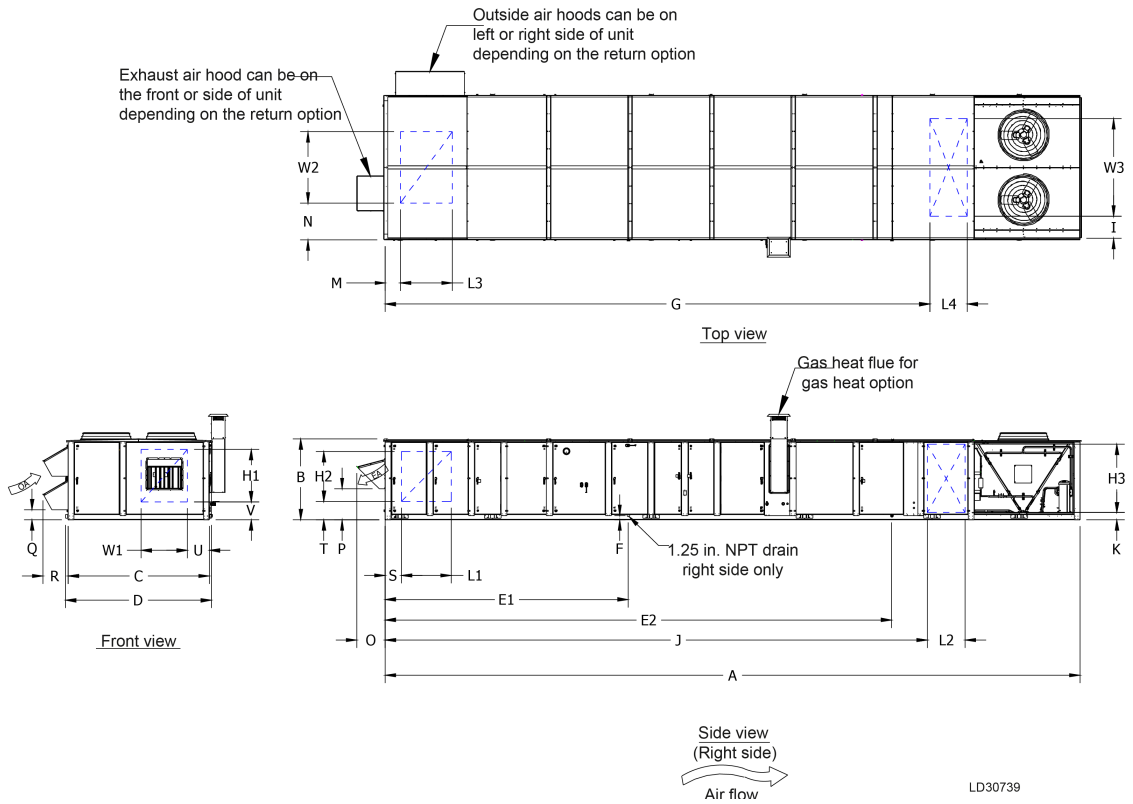

**Table 205: 25 ton to 30 ton unit dimensions (in.) for return options with an ERW**

Unit configuration	If unit has an exhaust fan with backdraft damper or modulating damper							
Dimension set	M	L3	W2	N	O	P	Q	R
Bottom return, right OA, side exhaust	86.63	51.36	31.94	59.92	19.26	21.00	7.00	17.17
Bottom return, right OA, front exhaust	86.63	51.36	31.94	59.92	19.26	21.00	7.00	17.17

**Table 206: 25 ton to 30 ton unit dimensions (in.) for return options without an ERW**

Unit configuration	If unit has a return fan with modulating damper								If unit has an exhaust fan with backdraft damper or modulating damper							
	M	L3	W2	N	O	P	Q	R	M	L3	W2	N	O	P	Q	R
Bottom return, right OA, side exhaust	13.76	33.73	37.61	44.37	35.45	10.22	7.00	17.17	13.76	33.73	51.00	33.45	19.26	21.00	7.00	17.17
Bottom return, right OA, front exhaust	13.76	33.73	37.61	44.37	35.45	10.22	7.00	17.17	13.76	33.73	51.00	33.45	19.26	21.00	7.00	17.17
Bottom return, left OA, side exhaust	13.76	33.73	37.61	14.07	35.45	10.22	7.00	17.17	13.76	33.73	51.00	11.70	19.26	21.00	7.00	17.17
Bottom return, left OA, front exhaust	13.76	33.73	37.61	14.07	35.45	10.22	7.00	17.17	13.76	33.73	51.00	11.70	19.26	21.00	7.00	17.17
Top return, right OA, side exhaust	N/A	N/A	N/A	N/A	N/A	N/A	N/A	N/A	8.98	38.00	45.26	25.50	19.26	21.00	7.00	17.17
Top return, right OA, front exhaust	N/A	N/A	N/A	N/A	N/A	N/A	N/A	N/A	8.98	38.00	45.26	25.50	19.26	21.00	7.00	17.17
Top return, left OA, side exhaust	N/A	N/A	N/A	N/A	N/A	N/A	N/A	N/A	8.98	38.00	45.26	25.50	19.26	21.00	7.00	17.17
Top return, left OA, front exhaust	N/A	N/A	N/A	N/A	N/A	N/A	N/A	N/A	8.98	38.00	45.26	25.50	19.26	21.00	7.00	17.17
Dimension set	S	L1	H2	T	O	P	Q	R	S	L1	H2	T	O	P	Q	R
Left return, right OA, front exhaust	11.01	39.00	39.00	10.34	35.45	10.22	7.00	17.17	10.51	40.00	40.00	8.19	19.26	21.00	7.00	17.17
Right return, left OA, front exhaust	11.01	39.00	39.00	10.34	35.45	10.22	7.00	17.17	10.51	40.00	40.00	8.19	19.26	21.00	7.00	17.17
Dimension set	U	W1	H1	V	O	P	Q	R	U	W1	H1	V	O	P	Q	R
Front return, left OA, right exhaust	11.01	39.00	39.00	10.34	35.45	10.22	7.00	17.17	10.51	40.00	40.00	8.19	19.26	21.00	7.00	17.17
Front return, right OA, left exhaust	46.24	39.00	39.00	10.34	35.45	10.22	7.00	17.17	45.74	40.00	40.00	8.19	19.26	21.00	7.00	17.17

Unit configuration	If unit has no fan and barometric damper							
Dimension set	M	L3	W2	N	O	P	Q	R
Bottom return, right OA, side exhaust	13.76	33.73	51.00	33.45	22.45	16.55	7.00	17.17
Bottom return, right OA, front exhaust	13.76	33.73	51.00	33.45	22.45	16.55	7.00	17.17
Bottom return, left OA, side exhaust	13.76	33.73	51.00	11.70	22.45	16.55	7.00	17.17
Bottom return, left OA, front exhaust	13.76	33.73	51.00	11.70	22.45	16.55	7.00	17.17
Bottom return, no OA, no EA	13.76	33.73	51.00	33.45	N/A	N/A	N/A	N/A
Top return, right OA, side exhaust	8.98	38.00	45.26	25.50	22.45	16.55	7.00	17.17
Top return, right OA, front exhaust	8.98	38.00	45.26	25.50	22.45	16.55	7.00	17.17
Top return, left OA, side exhaust	8.98	38.00	45.26	25.50	22.45	16.55	7.00	17.17
Top return, left OA, front exhaust	8.98	38.00	45.26	25.50	22.45	16.55	7.00	17.17
Top return, no OA, no EA	8.98	38.00	45.26	25.50	N/A	N/A	N/A	N/A
Dimension set	S	L1	H2	T	O	P	Q	R
Left return, right OA, front exhaust	10.51	40.00	40.00	8.19	22.45	16.55	7.00	17.17
Left return, no OA, no EA	10.51	40.00	40.00	8.19	N/A	N/A	N/A	N/A
Right return, left OA, front exhaust	10.51	40.00	40.00	8.19	22.45	16.55	7.00	17.17
Right return, no OA, no EA	10.51	40.00	40.00	8.19	N/A	N/A	N/A	N/A
Dimension set	U	W1	H1	V	O	P	Q	R
Front return, left OA, right exhaust	10.51	40.00	40.00	8.19	22.45	16.55	7.00	17.17
Front return, right OA, left exhaust	45.74	40.00	40.00	8.19	22.45	16.55	7.00	17.17
Front return, no OA, no EA	10.51	40.00	40.00	8.19	N/A	N/A	N/A	N/A

**Table 207: 25 ton to 30 ton unit dimensions (in.)**

		Unit configuration	Unit length (A)	Unit height (B)	Unit width (C)	Unit width lifting lug to lifting lug (D)	Evaporator drain length (E1)	Evaporator drain height (F)
No ERW	No heat	SU with vertical filter 4 in., DP (B, L, R, T)	264.40	55.00	96.05	100.00	95.50	2.50
		SU with DP (B, L, R, T)	281.40	55.00	96.05	100.00	112.50	2.50
		SU with pre-evap blank, small post-evap blank, DP (B, L, R, T)	379.40	55.00	96.05	100.00	165.50	2.50
		SU with pre-evap blank, large post-evap blank, DP (B, L, R, T)	421.40	55.00	96.05	100.00	165.50	2.50
		SU with small post-evap blank, DP (B, L, R, T)	326.40	55.00	96.05	100.00	112.50	2.50
	SU with large post-evap blank, DP (B, L, R, T)	374.90	55.00	96.05	100.00	112.50	2.50	
	Heat	SU with vertical filter 4 in., discharge through heat section (B, L)	281.40	55.00	96.05	100.00	95.50	2.50
		SU with discharge through heat section (B, L)	298.40	55.00	96.05	100.00	112.50	2.50
		SU with heat, DP (B, L, R, T)	333.00	55.00	96.05	100.00	112.50	2.50
		SU with pre-evap blank, discharge through heat section (B, L)	351.40	55.00	96.05	100.00	165.50	2.50
		SU with pre-evap blank, heat, DP (B, L, R, T)	386.00	55.00	96.05	100.00	165.50	2.50
		SU with pre-evap blank, heat, small post-evap blank, DP (B,L,R,T)	431.00	55.00	96.05	100.00	165.50	2.50
		SU with pre-evap blank, heat, large post-evap blank, DP (B,L,R,T)	473.00	55.00	96.05	100.00	165.50	2.50
		SU with heat, small post-evap blank, DP (B, L, R, T)	379.40	55.00	96.05	100.00	112.50	2.50
SU with heat, large post-evap blank, DP (B, L, R, T)	421.40	55.00	96.05	100.00	112.50	2.50		
ERW	No heat	SU with pre-evap blank, small post-evap blank, DP (B, L, R, T)	455.90	55.00	96.05	100.00	242.00	2.50
		SU with pre-evap blank, large post-evap blank, DP (B, L, R, T)	497.90	55.00	96.05	100.00	242.00	2.50
		SU with small post-evap blank, DP (B, L, R, T)	402.90	55.00	96.05	100.00	189.00	2.50
		SU with large post-evap blank, DP (B, L, R, T)	444.90	55.00	96.05	100.00	189.00	2.50
	Heat	SU with discharge through heat section (B, L)	374.90	55.00	96.05	100.00	189.00	2.50
		SU with heat, DP (B, L, R, T)	409.50	55.00	96.05	100.00	189.00	2.50
		SU with pre-evap blank, discharge through heat section (B, L)	431.00	55.00	96.05	100.00	245.10	2.50
		SU with pre-evap blank, heat, DP (B, L, R, T)	462.50	55.00	96.05	100.00	242.00	2.50
		SU with pre-evap blank, heat, small post-evap blank, DP (B, L, R, T)	507.50	55.00	96.05	100.00	242.00	2.50
		SU with pre-evap blank, heat, large post-evap blank, DP (B, L, R, T)	549.50	55.00	96.05	100.00	242.00	2.50
		SU with heat, small post-evap blank, DP (B, L, R, T)	455.90	55.00	96.05	100.00	189.00	2.50
		SU with heat, large post-evap blank, DP (B, L, R, T)	497.90	55.00	96.05	100.00	189.00	2.50

**Table 208: 25 ton to 30 ton unit dimensions (in.) with bottom and top discharge**

		Unit configuration	Bottom discharge				Top discharge			
			G	L4	I	W3	G	L4	I	W3
No ERW	No heat	SU with vertical filter 4 in., DP (B, L, R, T)	158.09	30.13	9.53	77.00	158.09	30.13	9.53	77.00
		SU with DP (B, L, R, T)	175.09	30.13	9.53	77.00	175.09	30.13	9.53	77.00
		SU with pre-evap blank, small post-evap blank, DP (B, L, R, T)	273.09	30.13	9.53	77.00	273.09	30.13	9.53	77.00
		SU with pre-evap blank, large post-evap blank, DP (B, L, R, T)	315.09	30.13	9.53	77.00	315.09	30.13	9.53	77.00
		SU with small post-evap blank, DP (B, L, R, T)	220.09	30.13	9.53	77.00	220.09	30.13	9.53	77.00
		SU with large post-evap blank, DP (B, L, R, T)	268.59	30.13	9.53	77.00	268.59	30.13	9.53	77.00
	Heat	SU with vertical filter 4 in., discharge through heat section (B, L)	162.75	40.00	25.89	50.00	N/A	N/A	N/A	N/A
		SU with discharge through heat section (B, L)	179.75	40.00	25.89	50.00	N/A	N/A	N/A	N/A
		SU with heat, DP (B, L, R, T)	226.69	30.13	9.53	77.00	226.69	30.13	9.53	77.00
		SU with pre-evap blank, discharge through heat section (B, L)	232.75	40.00	25.89	50.00	N/A	N/A	N/A	N/A
		SU with pre-evap blank, heat, DP (B, L, R, T)	279.69	30.13	9.53	77.00	279.69	30.13	9.53	77.00
		SU with pre-evap blank, heat, small post-evap blank, DP (B,L,R,T)	324.69	30.13	9.53	77.00	324.69	30.13	9.53	77.00
		SU with pre-evap blank, heat, large post-evap blank, DP (B,L,R,T)	366.69	30.13	9.53	77.00	366.69	30.13	9.53	77.00
		SU with heat, small post-evap blank, DP (B, L, R, T)	273.09	30.13	9.53	77.00	273.09	30.13	9.53	77.00
SU with heat, large post-evap blank, DP (B, L, R, T)	315.09	30.13	9.53	77.00	315.09	30.13	9.53	77.00		

**Table 208: 25 ton to 30 ton unit dimensions (in.) with bottom and top discharge**

		Unit configuration	Bottom discharge				Top discharge			
			G	L4	I	W3	G	L4	I	W3
ERW	No heat	SU with pre-evap blank, small post-evap blank, DP (B, L, R, T)	349.59	30.13	9.53	77.00	349.59	30.13	9.53	77.00
		SU with pre-evap blank, large post-evap blank, DP (B, L, R, T)	391.59	30.13	9.53	77.00	391.59	30.13	9.53	77.00
		SU with small post-evap blank, DP (B, L, R, T)	296.59	30.13	9.53	77.00	296.59	30.13	9.53	77.00
		SU with large post-evap blank, DP (B, L, R, T)	338.59	30.13	9.53	77.00	338.59	30.13	9.53	77.00
	Heat	SU with discharge through heat section (B, L)	256.25	40.00	25.89	50.00	N/A	N/A	N/A	N/A
		SU with heat, DP (B, L, R, T)	303.19	30.13	9.53	77.00	303.19	30.13	9.53	77.00
		SU with pre-evap blank, discharge through heat section (B, L)	312.35	40.00	25.89	50.00	N/A	N/A	N/A	N/A
		SU with pre-evap blank, heat, DP (B, L, R, T)	356.19	30.13	9.53	77.00	356.19	30.13	9.53	77.00
		SU with pre-evap blank, heat, small post-evap blank, DP (B, L, R, T)	401.19	30.13	9.53	77.00	401.19	30.13	9.53	77.00
		SU with pre-evap blank, heat, large post-evap blank, DP (B, L, R, T)	443.19	30.13	9.53	77.00	443.19	30.13	9.53	77.00
		SU with heat, small post-evap blank, DP (B, L, R, T)	349.59	30.13	9.53	77.00	349.59	30.13	9.53	77.00
		SU with heat, large post-evap blank, DP (B, L, R, T)	391.59	30.13	9.53	77.00	391.59	30.13	9.53	77.00

**Table 209: 25 ton to 30 ton unit dimensions (in.) with left and right discharge**

		Unit configuration	Left discharge				Right discharge			
			J	L2	K	H3	J	L2	K	H3
No ERW	No heat	SU with vertical filter 4 in., DP (B, L, R, T)	159.06	28.21	4.65	47.04	159.06	28.21	4.65	47.04
		SU with DP (B, L, R, T)	176.06	28.21	4.65	47.04	176.06	28.21	4.65	47.04
		SU with pre-evap blank, small post-evap blank, DP (B, L, R, T)	274.06	28.21	4.65	47.04	274.06	28.21	4.65	47.04
		SU with pre-evap blank, large post-evap blank, DP (B, L, R, T)	316.06	28.21	4.65	47.04	316.06	28.21	4.65	47.04
		SU with small post-evap blank, DP (B, L, R, T)	221.06	28.21	4.65	47.04	221.06	28.21	4.65	47.04
		SU with large post-evap blank, DP (B, L, R, T)	269.56	28.21	4.65	47.04	269.56	28.21	4.65	47.04
	Heat	SU with vertical filter 4 in., discharge through heat section (B, L)	160.75	43.00	15.09	34.00	N/A	N/A	N/A	N/A
		SU with discharge through heat section (B, L)	177.75	43.00	15.09	34.00	N/A	N/A	N/A	N/A
		SU with heat, DP (B, L, R, T)	227.66	28.21	4.65	47.04	227.66	28.21	4.65	47.04
		SU with pre-evap blank, discharge through heat section (B, L)	230.75	43.00	15.09	34.00	N/A	N/A	N/A	N/A
		SU with pre-evap blank, heat, DP (B, L, R, T)	280.66	28.21	4.65	47.04	280.66	28.21	4.65	47.04
		SU with pre-evap blank, heat, small post-evap blank, DP (B,L,R,T)	325.66	28.21	4.65	47.04	325.66	28.21	4.65	47.04
		SU with pre-evap blank, heat, large post-evap blank, DP (B,L,R,T)	367.66	28.21	4.65	47.04	367.66	28.21	4.65	47.04
		SU with heat, small post-evap blank, DP (B, L, R, T)	274.06	28.21	4.65	47.04	274.06	28.21	4.65	47.04
		SU with heat, large post-evap blank, DP (B, L, R, T)	316.06	28.21	4.65	47.04	316.06	28.21	4.65	47.04
		ERW	No heat	SU with pre-evap blank, small post-evap blank, DP (B, L, R, T)	350.56	28.21	4.65	47.04	350.56	28.21
SU with pre-evap blank, large post-evap blank, DP (B, L, R, T)	392.56			28.21	4.65	47.04	392.56	28.21	4.65	47.04
SU with small post-evap blank, DP (B, L, R, T)	297.56			28.21	4.65	47.04	297.56	28.21	4.65	47.04
SU with large post-evap blank, DP (B, L, R, T)	339.56			28.21	4.65	47.04	339.56	28.21	4.65	47.04
Heat	SU with discharge through heat section (B, L)		254.25	43.00	15.09	34.00	N/A	N/A	N/A	N/A
	SU with heat, DP (B, L, R, T)		304.16	28.21	4.65	47.04	304.16	28.21	4.65	47.04
	SU with pre-evap blank, discharge through heat section (B, L)		310.35	43.00	15.09	34.00	N/A	N/A	N/A	N/A
	SU with pre-evap blank, heat, DP (B, L, R, T)		357.16	28.21	4.65	47.04	357.16	28.21	4.65	47.04
	SU with pre-evap blank, heat, small post-evap blank, DP (B, L, R, T)		402.16	28.21	4.65	47.04	402.16	28.21	4.65	47.04
	SU with pre-evap blank, heat, large post-evap blank, DP (B, L, R, T)		444.16	28.21	4.65	47.04	444.16	28.21	4.65	47.04
	SU with heat, small post-evap blank, DP (B, L, R, T)		350.56	28.21	4.65	47.04	350.56	28.21	4.65	47.04
	SU with heat, large post-evap blank, DP (B, L, R, T)		392.56	28.21	4.65	47.04	392.56	28.21	4.65	47.04

**Note:**

1. A SU includes length for economizer, draw-through filter, cooling coil, supply fan, and condenser. A SU includes a draw-through (pre-evaporator) filter with 2 in. angle filter or 2 in. + 12 in. (or 18 in.) filter. Units with a vertical 4 in. draw-through filter in place of the standard 2 in. angle or 2 in. + 12 in. (or 18 in.) filter are listed as *SU with Vertical Filter 4 in.*
2. The heat section includes either gas, hot water, steam, or electric.
3. SU = Standard Unit, DP = Discharge Plenum, B = Bottom Discharge, L = Left Discharge, R = Right Discharge, T = Top Discharge
4. Dimensions are  $\pm 1$  in.

**Figure 16: 40 ton to 50 ton dimensional drawing**

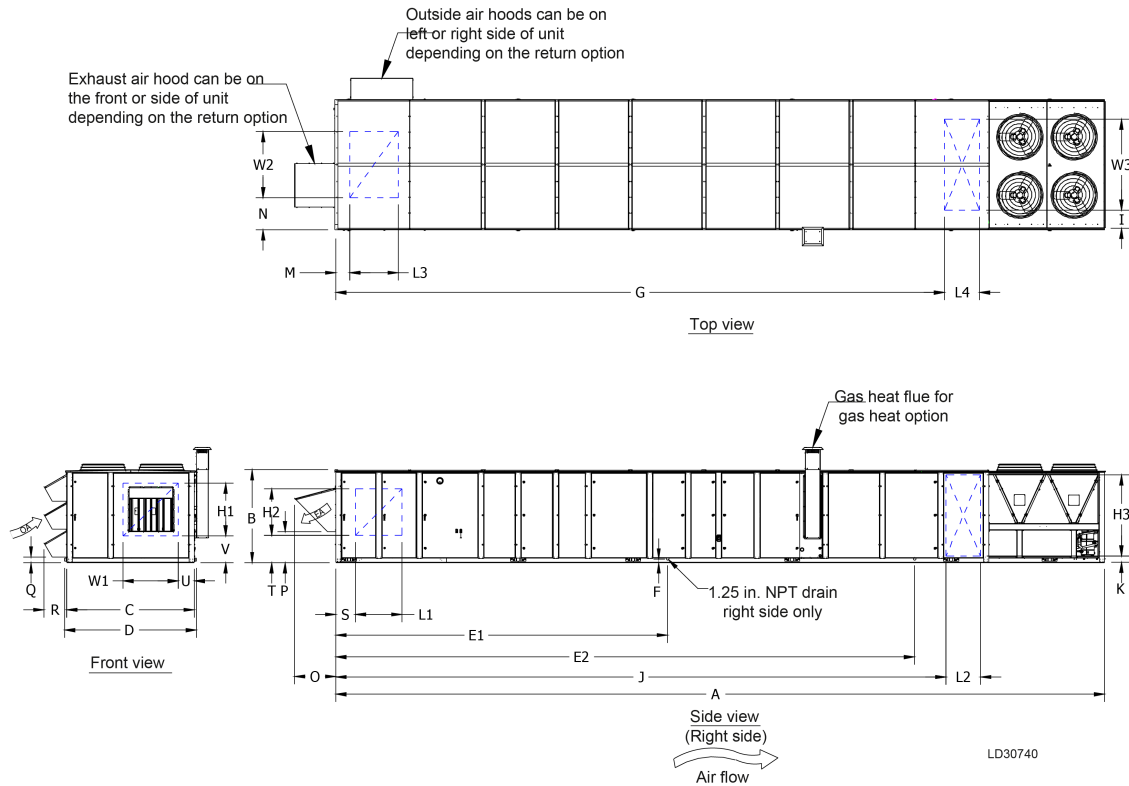

**Table 210: 40 ton to 50 ton unit dimensions (in.) for return options with an ERW**

Unit configuration	ERW only available with an exhaust fan with backdraft damper or modulating damper								
	Dimension set	M	L3	W2	N	O	P	Q	R
Bottom return, right OA, side exhaust		93.57	52.86	45.00	46.86	31.13	23.40	4.10	17.17
Bottom return, right OA, front exhaust		93.57	52.86	45.00	46.86	31.13	23.40	4.10	17.17

**Table 211: 40 to to 50 ton unit dimensions (in.) for return options without an ERW**

Unit configuration	If unit has a return fan with modulating damper								If unit has an exhaust fan with backdraft damper or modulating damper								
	Dimension set	M	L3	W2	N	O	P	Q	R	M	L3	W2	N	O	P	Q	R
Bottom return, right OA, side exhaust		13.76	37.63	41.51	42.82	46.77	14.46	4.10	17.17	13.76	37.63	72.99	18.88	31.13	23.40	4.10	17.17
Bottom return, right OA, front exhaust		13.76	37.63	41.51	42.82	46.77	14.46	4.10	17.17	13.76	37.63	72.99	18.88	31.13	23.40	4.10	17.17
Bottom return, left OA, side exhaust		13.76	37.63	41.51	11.71	46.77	14.46	4.10	17.17	13.76	37.63	72.99	4.18	31.13	23.40	4.10	17.17
Bottom return, left OA, front exhaust		13.76	37.63	41.51	11.71	46.77	14.46	4.10	17.17	13.76	37.63	72.99	4.18	31.13	23.40	4.10	17.17
Top return, right OA, side exhaust		N/A	N/A	N/A	N/A	N/A	N/A	N/A	N/A	4.31	47.34	58.04	19.10	31.13	23.40	4.10	17.17

**Table 211: 40 to to 50 ton unit dimensions (in.) for return options without an ERW**

Unit configuration	If unit has a return fan with modulating damper								If unit has an exhaust fan with backdraft damper or modulating damper							
	N/A	N/A	N/A	N/A	N/A	N/A	N/A	N/A	4.31	47.34	58.04	19.10	31.13	23.40	4.10	17.17
Top return, right OA, front exhaust	N/A	N/A	N/A	N/A	N/A	N/A	N/A	N/A	4.31	47.34	58.04	19.10	31.13	23.40	4.10	17.17
Top return, left OA, side exhaust	N/A	N/A	N/A	N/A	N/A	N/A	N/A	N/A	4.31	47.34	58.04	19.10	31.13	23.40	4.10	17.17
Top return, left OA, front exhaust	N/A	N/A	N/A	N/A	N/A	N/A	N/A	N/A	4.31	47.34	58.04	19.10	31.13	23.40	4.10	17.17
<b>Dimension set</b>	<b>S</b>	<b>L1</b>	<b>H2</b>	<b>T</b>	<b>O</b>	<b>P</b>	<b>Q</b>	<b>R</b>	<b>S</b>	<b>L1</b>	<b>H2</b>	<b>T</b>	<b>O</b>	<b>P</b>	<b>Q</b>	<b>R</b>
Left return, right OA, front exhaust	11.13	43.00	43.00	10.34	46.77	14.46	4.10	17.17	7.63	50.00	55.00	8.19	31.13	23.40	4.10	17.17
Right return, left OA, front exhaust	11.13	43.00	43.00	10.34	46.77	14.46	4.10	17.17	7.63	50.00	55.00	8.19	31.13	23.40	4.10	17.17
<b>Dimension set</b>	<b>U</b>	<b>W1</b>	<b>H1</b>	<b>V</b>	<b>O</b>	<b>P</b>	<b>Q</b>	<b>R</b>	<b>U</b>	<b>W1</b>	<b>H1</b>	<b>V</b>	<b>O</b>	<b>P</b>	<b>Q</b>	<b>R</b>
Front return, left OA, right exhaust	11.13	43.00	43.00	10.34	46.77	14.46	4.10	17.17	7.63	50.00	55.00	8.19	31.13	23.40	4.10	17.17
Front return, right OA, left exhaust	42.12	43.00	43.00	10.34	46.77	14.46	4.10	17.17	38.62	50.00	55.00	8.19	31.13	23.40	4.10	17.17

Unit configuration	If unit has no fan and barometric damper							
	M	L3	W2	N	O	P	Q	R
<b>Dimension set</b>	<b>M</b>	<b>L3</b>	<b>W2</b>	<b>N</b>	<b>O</b>	<b>P</b>	<b>Q</b>	<b>R</b>
Bottom return, right OA, side exhaust	13.76	37.63	72.99	18.88	29.16	20.18	4.10	17.17
Bottom return, right OA, front exhaust	13.76	37.63	72.99	18.88	29.16	20.18	4.10	17.17
Bottom return, left OA, side exhaust	13.76	37.63	72.99	4.18	29.16	20.18	4.10	17.17
Bottom return, left OA, front exhaust	13.76	37.63	72.99	4.18	29.16	20.18	4.10	17.17
Bottom return, no OA, no EA	13.76	37.63	72.99	18.88	N/A	N/A	N/A	N/A
Top return, right OA, side exhaust	4.31	47.34	58.04	19.10	29.16	20.18	4.10	17.17
Top return, right OA, front exhaust	4.31	47.34	58.04	19.10	29.16	20.18	4.10	17.17
Top return, left OA, side exhaust	4.31	47.34	58.04	19.10	29.16	20.18	4.10	17.17
Top return, left OA, front exhaust	4.31	47.34	58.04	19.10	29.16	20.18	4.10	17.17
Top return, no OA, no EA	4.31	47.34	58.04	19.10	N/A	N/A	N/A	N/A
<b>Dimension set</b>	<b>S</b>	<b>L1</b>	<b>H2</b>	<b>T</b>	<b>O</b>	<b>P</b>	<b>Q</b>	<b>R</b>
Left return, right OA, front exhaust	7.63	50.00	55.00	8.19	29.16	20.18	4.10	17.17
Left return, no OA, no EA	7.63	50.00	55.00	8.19	N/A	N/A	N/A	N/A
Right return, left OA, front exhaust	7.63	50.00	55.00	8.19	29.16	20.18	4.10	17.17
Right return, no OA, no EA	7.63	50.00	55.00	8.19	N/A	N/A	N/A	N/A
<b>Dimension set</b>	<b>U</b>	<b>W1</b>	<b>H1</b>	<b>V</b>	<b>O</b>	<b>P</b>	<b>Q</b>	<b>R</b>
Front return, left OA, right exhaust	7.63	50.00	55.00	8.19	29.16	20.18	4.10	17.17
Front return, right OA, left exhaust	38.62	50.00	55.00	8.19	29.16	20.18	4.10	17.17
Front return, no OA, no EA	7.63	50.00	55.00	8.19	N/A	N/A	N/A	N/A

**Table 212: 40 ton to 50 ton unit dimensions (in.)**

Unit configuration		Unit length (A)	Unit height (B)	Unit width (C)	Unit width lifting lug to lifting lug (D)	Evaporator drain length (E)	Evaporator drain height (F)	
No ERW	No heat	SU with vertical filter 4 in., DP (B, L, R, T)	297.20	70.00	96.05	100.00	106.00	2.50
		SU with DP (B, L, R, T)	314.20	70.00	96.05	100.00	123.00	2.50
		SU with pre-evap blank, small post-evap blank, DP (B, L, R, T)	412.20	70.00	96.05	100.00	176.00	2.50
		SU with pre-evap blank, large post-evap blank, DP (B, L, R, T)	454.20	70.00	96.05	100.00	176.00	2.50
		SU with small post-evap blank, DP (B, L, R, T)	359.20	70.00	96.05	100.00	123.00	2.50
		SU with large post-evap blank, DP (B, L, R, T)	405.70	70.00	96.05	100.00	123.00	2.50
	Heat	SU with vertical filter 4 in., discharge through heat section (B, L)	314.20	70.00	96.05	100.00	106.00	2.50
		SU with discharge through heat section (B, L)	331.20	70.00	96.05	100.00	123.00	2.50
		SU with heat, DP (B, L, R, T)	365.80	70.00	96.05	100.00	123.00	2.50
		SU with pre-evap blank, discharge through heat section (B, L)	384.20	70.00	96.05	100.00	176.00	2.50
		SU with pre-evap blank, heat, DP (B, L, R, T)	418.80	70.00	96.05	100.00	176.00	2.50
		SU with pre-evap blank, heat, small post-evap blank, DP (B,L,R,T)	463.80	70.00	96.05	100.00	176.00	2.50
		SU with pre-evap blank, heat, large post-evap blank, DP (B,L,R,T)	505.80	70.00	96.05	100.00	176.00	2.50
		SU with heat, small post-evap blank, DP (B, L, R, T)	412.20	70.00	96.05	100.00	123.00	2.50
SU with heat, large post-evap blank, DP (B, L, R, T)	454.20	70.00	96.05	100.00	123.00	2.50		

**Table 212: 40 ton to 50 ton unit dimensions (in.)**

		Unit configuration	Unit length (A)	Unit height (B)	Unit width (C)	Unit width lifting lug to lifting lug (D)	Evaporator drain length (E)	Evaporator drain height (F)
ERW	No heat	SU with pre-evap blank, small post-evap blank, DP (B, L, R, T)	486.70	70.00	96.05	100.00	250.50	2.50
		SU with pre-evap blank, large post-evap blank, DP (B, L, R, T)	528.70	70.00	96.05	100.00	250.50	2.50
		SU with small post-evap blank, DP (B, L, R, T)	433.70	70.00	96.05	100.00	197.50	2.50
		SU with large post-evap blank, DP (B, L, R, T)	475.70	70.00	96.05	100.00	197.50	2.50
	Heat	SU with discharge through heat section (B, L)	405.70	70.00	96.05	100.00	197.50	2.50
		SU with heat, DP (B, L, R, T)	440.30	70.00	96.05	100.00	197.50	2.50
		SU with pre-evap blank, discharge through heat section (B, L)	463.80	70.00	96.05	100.00	255.60	2.50
		SU with pre-evap blank, heat, DP (B, L, R, T)	493.30	70.00	96.05	100.00	250.50	2.50
		SU with pre-evap blank, heat, small post-evap blank, DP (B, L, R, T)	538.30	70.00	96.05	100.00	250.50	2.50
		SU with pre-evap blank, heat, large post-evap blank, DP (B, L, R, T)	580.30	70.00	96.05	100.00	250.50	2.50
		SU with heat, small post-evap blank, DP (B, L, R, T)	486.70	70.00	96.05	100.00	197.50	2.50
		SU with heat, large post-evap blank, DP (B, L, R, T)	528.70	70.00	96.05	100.00	197.50	2.50

**Table 213: 40 ton to 50 ton unit dimensions (in.) with bottom and top discharge**

		Unit configuration	Bottom discharge				Top discharge			
			G	L4	I	W3	G	L4	I	W3
No ERW	No heat	SU with vertical filter 4 in., DP (B, L, R, T)	175.59	30.13	9.53	77.00	175.59	30.13	9.53	77.00
		SU with DP (B, L, R, T)	192.59	30.13	9.53	77.00	192.59	30.13	9.53	77.00
		SU with pre-evap blank, small post-evap blank, DP (B, L, R, T)	290.59	30.13	9.53	77.00	290.59	30.13	9.53	77.00
		SU with pre-evap blank, large post-evap blank, DP (B, L, R, T)	332.59	30.13	9.53	77.00	332.59	30.13	9.53	77.00
		SU with small post-evap blank, DP (B, L, R, T)	237.59	30.13	9.53	77.00	237.59	30.13	9.53	77.00
		SU with large post-evap blank, DP (B, L, R, T)	284.09	30.13	9.53	77.00	284.09	30.13	9.53	77.00
	Heat	SU with vertical filter 4 in., discharge through heat section (B, L)	180.25	40.00	25.89	50.00	N/A	N/A	N/A	N/A
		SU with discharge through heat section (B, L)	197.25	40.00	25.89	50.00	N/A	N/A	N/A	N/A
		SU with heat, DP (B, L, R, T)	244.19	30.13	9.53	77.00	244.19	30.13	9.53	77.00
		SU with pre-evap blank, discharge through heat section (B, L)	250.25	40.00	25.89	50.00	N/A	N/A	N/A	N/A
		SU with pre-evap blank, heat, DP (B, L, R, T)	297.19	30.13	9.53	77.00	297.19	30.13	9.53	77.00
		SU with pre-evap blank, heat, small post-evap blank, DP (B,L,R,T)	342.19	30.13	9.53	77.00	342.19	30.13	9.53	77.00
		SU with pre-evap blank, heat, large post-evap blank, DP (B,L,R,T)	384.19	30.13	9.53	77.00	384.19	30.13	9.53	77.00
		SU with heat, small post-evap blank, DP (B, L, R, T)	290.59	30.13	9.53	77.00	290.59	30.13	9.53	77.00
SU with heat, large post-evap blank, DP (B, L, R, T)	332.59	30.13	9.53	77.00	332.59	30.13	9.53	77.00		
ERW	No heat	SU with pre-evap blank, small post-evap blank, DP (B, L, R, T)	365.09	30.13	9.53	77.00	365.09	30.13	9.53	77.00
		SU with pre-evap blank, large post-evap blank, DP (B, L, R, T)	407.09	30.13	9.53	77.00	407.09	30.13	9.53	77.00
		SU with small post-evap blank, DP (B, L, R, T)	312.09	30.13	9.53	77.00	312.09	30.13	9.53	77.00
		SU with large post-evap blank, DP (B, L, R, T)	354.09	30.13	9.53	77.00	354.09	30.13	9.53	77.00
	Heat	SU with discharge through heat section (B, L)	271.75	40.00	25.89	50.00	N/A	N/A	N/A	N/A
		SU with heat, DP (B, L, R, T)	318.69	30.13	9.53	77.00	318.69	30.13	9.53	77.00
		SU with pre-evap blank, discharge through heat section (B, L)	329.85	40.00	25.89	50.00	N/A	N/A	N/A	N/A
		SU with pre-evap blank, heat, DP (B, L, R, T)	371.69	30.13	9.53	77.00	371.69	30.13	9.53	77.00
		SU with pre-evap blank, heat, small post-evap blank, DP (B, L, R, T)	416.69	30.13	9.53	77.00	416.69	30.13	9.53	77.00
		SU with pre-evap blank, heat, large post-evap blank, DP (B, L, R, T)	458.69	30.13	9.53	77.00	458.69	30.13	9.53	77.00
SU with heat, small post-evap blank, DP (B, L, R, T)	365.09	30.13	9.53	77.00	365.09	30.13	9.53	77.00		
SU with heat, large post-evap blank, DP (B, L, R, T)	407.09	30.13	9.53	77.00	407.09	30.13	9.53	77.00		

**Table 214: 40 ton to 50 ton unit dimensions (in.) with left and right discharge**

		Unit configuration	Left discharge				Right discharge			
			J	L2	K	H3	J	L2	K	H3
No ERW	No heat	SU with vertical filter 4 in., DP (B, L, R, T)	176.56	28.21	4.65	62.04	176.56	28.21	4.65	62.04
		SU with DP (B, L, R, T)	193.56	28.21	4.65	62.04	193.56	28.21	4.65	62.04
		SU with pre-evap blank, small post-evap blank, DP (B, L, R, T)	291.56	28.21	4.65	62.04	291.56	28.21	4.65	62.04
		SU with pre-evap blank, large post-evap blank, DP (B, L, R, T)	333.56	28.21	4.65	62.04	333.56	28.21	4.65	62.04
		SU with small post-evap blank, DP (B, L, R, T)	238.56	28.21	4.65	62.04	238.56	28.21	4.65	62.04
		SU with large post-evap blank, DP (B, L, R, T)	285.06	28.21	4.65	62.04	285.06	28.21	4.65	62.04
	Heat	SU with vertical filter 4 in., discharge through heat section (B, L)	180.25	40.00	14.09	50.00	N/A	N/A	N/A	N/A
		SU with discharge through heat section (B, L)	197.25	40.00	14.09	50.00	N/A	N/A	N/A	N/A
		SU with heat, DP (B, L, R, T)	245.16	28.21	4.65	62.04	245.16	28.21	4.65	62.04
		SU with pre-evap blank, discharge through heat section (B, L)	250.25	40.00	14.09	50.00	N/A	N/A	N/A	N/A
		SU with pre-evap blank, heat, DP (B, L, R, T)	298.16	28.21	4.65	62.04	298.16	28.21	4.65	62.04
		SU with pre-evap blank, heat, small post-evap blank, DP (B,L,R,T)	343.16	28.21	4.65	62.04	343.16	28.21	4.65	62.04
		SU with pre-evap blank, heat, large post-evap blank, DP (B,L,R,T)	385.16	28.21	4.65	62.04	385.16	28.21	4.65	62.04
		SU with heat, small post-evap blank, DP (B, L, R, T)	291.56	28.21	4.65	62.04	291.56	28.21	4.65	62.04
SU with heat, large post-evap blank, DP (B, L, R, T)	333.56	28.21	4.65	62.04	333.56	28.21	4.65	62.04		
ERW	No heat	SU with pre-evap blank, small post-evap blank, DP (B, L, R, T)	366.06	28.21	4.65	62.04	366.06	28.21	4.65	62.04
		SU with pre-evap blank, large post-evap blank, DP (B, L, R, T)	408.06	28.21	4.65	62.04	408.06	28.21	4.65	62.04
		SU with small post-evap blank, DP (B, L, R, T)	313.06	28.21	4.65	62.04	313.06	28.21	4.65	62.04
		SU with large post-evap blank, DP (B, L, R, T)	355.06	28.21	4.65	62.04	355.06	28.21	4.65	62.04
	Heat	SU with discharge through heat section (B, L)	271.75	40.00	14.09	50.00	N/A	N/A	N/A	N/A
		SU with heat, DP (B, L, R, T)	319.66	28.21	4.65	62.04	319.66	28.21	4.65	62.04
		SU with pre-evap blank, discharge through heat section (B, L)	329.85	40.00	14.09	50.00	N/A	N/A	N/A	N/A
		SU with pre-evap blank, heat, DP (B, L, R, T)	372.66	28.21	4.65	62.04	372.66	28.21	4.65	62.04
		SU with pre-evap blank, heat, small post-evap blank, DP (B, L, R, T)	417.66	28.21	4.65	62.04	417.66	28.21	4.65	62.04
		SU with pre-evap blank, heat, large post-evap blank, DP (B, L, R, T)	459.66	28.21	4.65	62.04	459.66	28.21	4.65	62.04
		SU with heat, small post-evap blank, DP (B, L, R, T)	366.06	28.21	4.65	62.04	366.06	28.21	4.65	62.04
		SU with heat, large post-evap blank, DP (B, L, R, T)	408.06	28.21	4.65	62.04	408.06	28.21	4.65	62.04

**Note:**

1. A SU includes length for economizer, draw-through filter, cooling coil, supply fan, and condenser. A SU includes a draw-through (pre-evaporator) filter with 2 in. angle filter or 2 in. + 12 in. (or 18 in.) filter. Units with a vertical 4 in. draw-through filter in place of the standard 2 in. angle or 2 in. + 12 in. (or 18 in.) filter are listed as *SU with Vertical Filter 4 in.*
2. Basic economizer unit does not include an exhaust fan or return fan option.
3. The heat section includes either gas, hot water, steam, or electric.
4. SU = Standard Unit, DP = Discharge Plenum, B = Bottom Discharge, L = Left Discharge, R = Right Discharge, T = Top Discharge.
5. Dimensions are ± 1 in.

**Figure 17: 60 ton dimensional drawing**

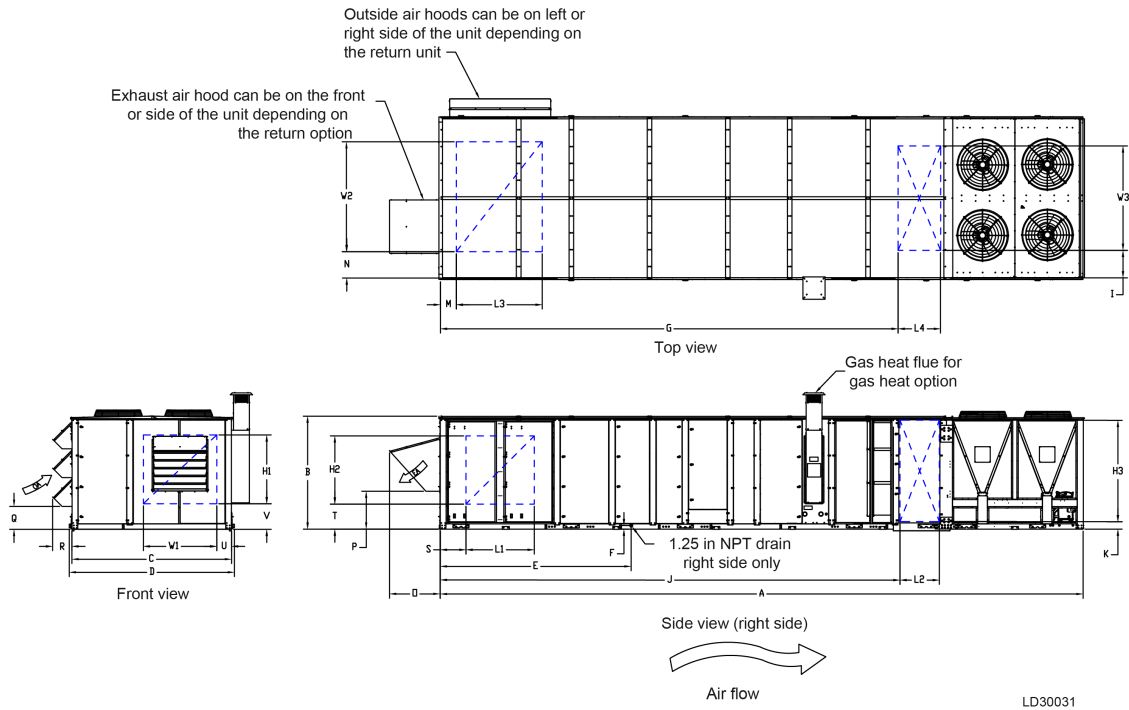

**Table 215: 60 ton unit dimensions (in.) for return options with an ERW**

Unit configuration	If unit has an exhaust fan with backdraft damper or modulating damper							
Dimension set	M	L3	W2	N	O	P	Q	R
Bottom return, right OA, side exhaust	111.48	53.92	54.48	54.39	24.29	21.48	16.17	13.93
Bottom return, right OA, front exhaust	111.48	53.92	54.48	54.39	24.29	21.48	16.17	13.93

**Table 216: 60 ton unit dimensions (in.) for return options without an ERW**

Unit configuration	If unit has a return fan with modulating damper								If unit has an exhaust fan with backdraft damper or modulating damper							
	M	L3	W2	N	O	P	Q	R	M	L3	W2	N	O	P	Q	R
Bottom return, right OA, side exhaust	13.66	41.63	45.51	54.71	47.06	15.98	16.17	13.93	13.66	56.91	71.31	31.05	35.95	26.92	16.17	13.93
Bottom return, right OA, front exhaust	13.66	41.63	45.51	54.71	47.06	15.98	16.17	13.93	13.66	56.91	77.87	31.05	35.95	26.92	16.17	13.93
Bottom return, left OA, side exhaust	13.66	41.63	45.51	12.83	47.06	15.98	16.17	13.93	13.66	56.91	71.31	10.69	35.95	26.92	16.17	13.93
Bottom return, left OA, front exhaust	13.66	41.63	45.51	12.83	47.06	15.98	16.17	13.93	13.66	56.91	77.87	4.13	35.95	26.92	16.17	13.93
Top return, right OA, side exhaust	-	-	-	-	-	-	-	-	3.23	49.30	82.59	28.69	35.95	26.92	16.17	13.93
Top return, right OA, front exhaust	-	-	-	-	-	-	-	-	3.23	49.30	82.59	28.69	35.95	26.92	16.17	13.93
Top return, left OA, side exhaust	-	-	-	-	-	-	-	-	3.23	49.30	82.59	1.8	35.95	26.92	16.17	13.93
Top return, left OA, front exhaust	-	-	-	-	-	-	-	-	3.23	49.30	82.59	1.8	35.95	26.92	16.17	13.93
<b>Dimension set</b>	<b>S</b>	<b>L1</b>	<b>H2</b>	<b>T</b>	<b>O</b>	<b>P</b>	<b>Q</b>	<b>R</b>	<b>S</b>	<b>L1</b>	<b>H2</b>	<b>T</b>	<b>O</b>	<b>P</b>	<b>Q</b>	<b>R</b>
Left return, right OA, front exhaust	18.99	47	47	10.34	47.06	15.98	16.17	13.93	5.09	74.78	66.11	7.64	35.95	26.92	16.17	13.93
Right return, left OA, front exhaust	18.99	47	47	10.34	47.06	15.98	16.17	13.93	5.09	74.78	66.11	7.64	35.95	26.92	16.17	13.93
<b>Dimension set</b>	<b>S</b>	<b>W1</b>	<b>H1</b>	<b>V</b>	<b>O</b>	<b>P</b>	<b>Q</b>	<b>R</b>	<b>S</b>	<b>W1</b>	<b>H1</b>	<b>V</b>	<b>O</b>	<b>P</b>	<b>Q</b>	<b>R</b>
Front Return, left OA, right exhaust	12.79	47	47	10.34	47.06	15.98	16.17	13.93	5.09	62.40	66.11	7.64	35.95	26.92	16.17	13.93
Front return, right OA, left exhaust	53.25	47	47	10.34	47.06	15.98	16.17	13.93	45.56	62.40	66.11	7.64	35.95	26.92	16.17	13.93

**Table 217: 60 ton unit dimensions (in.) for return options without an ERW**

Unit configuration	If unit has no fan and barometric damper							
	M	L3	W2	N	O	P	Q	R
Bottom return, right OA, side exhaust	6.13	54.28	65.00	43.92	33.23	23.08	11.27	13.93
Bottom return, right OA, front exhaust	6.13	54.28	65.00	43.92	33.23	23.08	11.27	13.93
Bottom return, left OA, side exhaust	6.13	54.28	65.00	4.13	33.23	23.08	11.27	13.93
Bottom return, left OA, front exhaust	6.13	54.28	65.00	4.13	33.23	23.08	11.27	13.93
Bottom return, no OA, no EA	6.13	54.28	65.00	43.92	-	-	-	-
Top return, right OA, side exhaust	3.23	49.30	71.29	40.01	33.23	23.08	11.27	17.46
Top return, right OA, front exhaust	3.23	49.30	71.29	40.01	33.23	23.08	11.27	17.46
Top return, left OA, side exhaust	3.23	49.30	71.29	1.76	33.23	23.08	11.27	17.46
Top return, left OA, front exhaust	3.23	49.30	71.29	1.76	33.23	23.08	11.27	17.46
Top return, no OA, no EA	3.23	49.30	71.29	40.01	-	-	-	-
<b>Dimension set</b>	<b>S</b>	<b>L1</b>	<b>H2</b>	<b>T</b>	<b>O</b>	<b>P</b>	<b>Q</b>	<b>R</b>
Left return, right OA, front exhaust	5.09	50.78	66.05	7.67	33.23	23.08	11.27	13.93
Left return, no OA, no EA	5.09	50.78	66.05	7.67	-	-	-	-
Right return, left OA, front exhaust	5.09	50.78	66.05	7.67	33.23	23.08	11.27	17.46
Right return, no OA, no EA	5.09	50.78	66.05	7.67	-	-	-	-
<b>Dimension set</b>	<b>U</b>	<b>W1</b>	<b>H1</b>	<b>V</b>	<b>O</b>	<b>P</b>	<b>Q</b>	<b>R</b>
Front return, left OA, right exhaust	5.09	62.40	66.10	7.64	33.23	23.08	11.27	17.46
Front return, right OA, left exhaust	45.56	62.40	66.10	7.64	33.23	23.08	11.27	17.46
Front return, no OA, no EA	45.56	62.40	66.10	7.64	-	-	-	-

**Table 218: 60 ton unit dimensions (in.)**

		Unit configuration	Unit length (A)	Unit height (B)	Unit width (C)	Unit width lifting lug to lifting lug (D)	Evaporator drain length (E)	Evaporator drain height (F)
Basic economizer - no ERW	No heat - 55 in. supply fan	SU with 4 in. vertical filter, discharge plenum (B,L,R,T)	298.54	80.00	113.36	117.00	94.50	2.50
		SU with discharge plenum (B,L,R,T)	315.54	80.00	113.36	117.00	111.50	2.50
		SU with small post-evap blank, discharge plenum (B,L,R,T)	360.54	80.00	113.36	117.06	111.50	2.50
		SU with pre-evap blank, small post-evap blank, discharge plenum (B,L,R,T)	413.54	80.00	113.36	117.06	164.50	2.50
		SU with large post-evap blank, discharge plenum (B,L,R,T)	402.54	80.00	113.36	117.06	111.50	2.50
		SU with pre-evap blank, large post-evap blank, discharge plenum (B,L,R,T)	455.54	80.00	113.36	117.06	164.50	2.50
	No heat - 74 in. supply fan	SU with small post-evap blank, discharge plenum (B,L,R,T)	379.54	80.00	113.36	117.00	111.50	2.50
		SU with pre-evap blank, small post-evap blank, discharge plenum (B,L,R,T)	432.54	80.00	113.36	117.06	164.50	2.50
		SU with large post-evap blank, discharge plenum (B,L,R,T)	421.54	80.00	113.36	117.06	111.50	2.50
		SU with pre-evap blank, large post-evap blank, discharge plenum (B,L,R,T)	474.54	80.00	113.36	117.06	164.50	2.50
	Heat	SU with 4 in. vertical filter, discharge through heat section (B,L)	334.54	80.00	113.36	117.00	94.50	2.50
		SU, discharge through heat section (B,L)	351.54	80.00	113.36	117.00	111.50	2.50
		SU with pre-evap blank, discharge through heat section (B,L)	404.54	80.00	113.36	117.06	164.50	2.50
		SU with heat, discharge plenum (B,L,R,T)	387.54	80.00	113.36	117.00	111.50	2.50
		SU with pre-evap blank, heat, discharge plenum (B,L,R,T)	440.54	80.00	113.36	117.06	164.50	2.50
		SU with heat, small post-evap blank, discharge plenum (B,L,R,T)	432.54	80.00	113.36	117.00	111.50	2.50
		SU with pre-evap blank, heat, small post-evap blank, discharge plenum (B,L,R,T)	485.54	80.00	113.36	117.06	164.50	2.50
		SU with heat, large post-evap blank, discharge plenum (B,L,R,T)	474.54	80.00	113.36	117.06	111.50	2.50
	SU with pre-evap blank, heat, large post-evap blank, discharge plenum (B,L,R,T)	527.54	80.00	113.36	117.06	164.50	2.50	

**Table 218: 60 ton unit dimensions (in.)**

		Unit configuration	Unit length (A)	Unit height (B)	Unit width (C)	Unit width lifting lug to lifting lug (D)	Evaporator drain length (E)	Evaporator drain height (F)	
Standard economizer - no ERW	No heat - 55 in. supply fan	SU with 4 in. vertical filter, discharge plenum (B,L,R,T)	322.54	80.00	113.36	117.00	118.50	2.50	
		SU with discharge plenum (B,L,R,T)	339.54	80.00	113.36	117.00	135.50	2.50	
		SU with small post-evap blank, discharge plenum (B,L,R,T)	384.54	80.00	113.36	117.06	135.50	2.50	
		SU with pre-evap blank, small post-evap blank, discharge plenum (B,L,R,T)	437.54	80.00	113.36	117.06	188.50	2.50	
		SU with large post-evap blank, discharge plenum (B,L,R,T)	426.54	80.00	113.36	117.06	135.50	2.50	
	No heat - 74 in. supply fan	SU with pre-evap blank, large post-evap blank, discharge plenum (B,L,R,T)	479.54	80.00	113.36	117.06	188.50	2.50	
		SU with small post-evap blank, discharge plenum (B,L,R,T)	403.54	80.00	113.36	117.00	135.50	2.50	
		SU with pre-evap blank, small post-evap blank, discharge plenum (B,L,R,T)	456.54	80.00	113.36	117.06	188.50	2.50	
		SU with large post-evap blank, discharge plenum (B,L,R,T)	445.54	80.00	113.36	117.06	135.50	2.50	
	Heat	SU with pre-evap blank, large post-evap blank, discharge plenum (B,L,R,T)	498.54	80.00	113.36	117.06	188.50	2.50	
		SU with 4 in. vertical filter, discharge through heat section (B,L)	358.54	80.00	113.36	117.00	118.50	2.50	
		SU, discharge through heat section (B,L)	375.54	80.00	113.36	117.00	135.50	2.50	
		SU with pre-evap blank, discharge through heat section (B,L)	428.54	80.00	113.36	117.06	188.50	2.50	
		SU with heat, discharge plenum (B,L,R,T)	411.54	80.00	113.36	117.00	135.50	2.50	
		SU with pre-evap blank, heat, discharge plenum (B,L,R,T)	464.54	80.00	113.36	117.06	188.50	2.50	
		SU with heat, small post-evap blank, discharge plenum (B,L,R,T)	456.54	80.00	113.36	117.00	135.50	2.50	
		SU with pre-evap blank, heat, small post-evap blank, discharge plenum (B,L,R,T)	509.54	80.00	113.36	117.06	188.50	2.50	
	Standard economizer - ERW	No heat - 55 in. supply fan	SU with heat, large post-evap blank, discharge plenum (B,L,R,T)	498.54	80.00	113.36	117.06	135.50	2.50
			SU with pre-evap blank, heat, large post-evap blank, discharge plenum (B,L,R,T)	551.54	80.00	113.36	117.06	188.50	2.50
			SU with small post-evap blank, discharge plenum (B,L,R,T)	465.54	80.00	113.36	117.06	216.50	2.50
		No heat - 74 in. supply fan	SU with pre-evap blank, small post-evap blank, discharge plenum (B,L,R,T)	518.54	80.00	113.36	117.06	269.50	2.50
SU with large post-evap blank, discharge plenum (B,L,R,T)			507.54	80.00	113.36	117.06	216.50	2.50	
SU with pre-evap blank, large post-evap blank, discharge plenum (B,L,R,T)			560.54	80.00	113.36	117.06	269.50	2.50	
Heat		SU with small post-evap blank, discharge plenum (B,L,R,T)	484.54	80.00	113.36	117.06	216.50	2.50	
		SU with pre-evap blank, small post-evap blank, discharge plenum (B,L,R,T)	537.54	80.00	113.36	117.06	269.50	2.50	
		SU with large post-evap blank, discharge plenum (B,L,R,T)	526.54	80.00	113.36	117.06	216.50	2.50	
		SU with pre-evap blank, large post-evap blank, discharge plenum (B,L,R,T)	579.54	80.00	113.36	117.06	269.50	2.50	
		SU, discharge through heat section (B,L)	456.54	80.00	113.36	117.06	216.50	2.50	
		SU with pre-evap blank, discharge through heat section (B,L)	509.54	80.00	113.36	117.06	269.50	2.50	
		SU with heat, discharge plenum (B,L,R,T)	492.54	80.00	113.36	117.06	216.50	2.50	
SU with pre-evap blank, heat, discharge plenum (B,L,R,T)		545.54	80.00	113.36	117.06	269.50	2.50		
SU with heat, small post-evap blank, discharge plenum (B,L,R,T)	537.54	80.00	113.36	117.06	216.50	2.50			
SU with pre-evap blank, heat, small post-evap blank, discharge plenum (B,L,R,T)	590.54	80.00	113.36	117.06	269.50	2.50			
SU with heat, large post-evap blank, discharge plenum (B,L,R,T)	579.54	80.00	113.36	117.06	216.50	2.50			
SU with pre-evap blank, heat, large post-evap blank, discharge plenum (B,L,R,T)	632.54	80.00	113.36	117.06	269.50	2.50			

**Table 219: 60 ton unit dimensions (in.) with bottom and top discharge**

		Unit configuration	Bottom discharge				Top discharge				
			G	L4	I	W3	G	L4	I	W3	
Basic economizer - no ERW	No heat - 55 in. supply fan	SU with 4 in. vertical filter, discharge plenum (B,L,R,T)	167.19	30.00	19.52	74.00	167.19	30.00	19.52	74.00	
		SU with discharge plenum (B,L,R,T)	184.19	30.00	19.52	74.00	184.19	30.00	19.52	74.00	
		SU with small post-evap blank, discharge plenum (B,L,R,T)	229.19	30.00	19.52	74.00	229.19	30.00	19.52	74.00	
		SU with pre-evap blank, small post-evap blank, discharge plenum (B,L,R,T)	282.19	30.00	19.52	74.00	282.19	30.00	19.52	74.00	
		SU with large post-evap blank, discharge plenum (B,L,R,T)	271.19	30.00	19.52	74.00	271.19	30.00	19.52	74.00	
	No heat - 74 in. supply fan	SU with pre-evap blank, large post-evap blank, discharge plenum (B,L,R,T)	324.19	30.00	19.52	74.00	324.19	30.00	19.52	74.00	
		SU with small post-evap blank, discharge plenum (B,L,R,T)	248.19	30.00	19.52	74.00	248.19	30.00	19.52	74.00	
		SU with pre-evap blank, small post-evap blank, discharge plenum (B,L,R,T)	301.19	30.00	19.52	74.00	301.19	30.00	19.52	74.00	
		SU with large post-evap blank, discharge plenum (B,L,R,T)	290.19	30.00	19.52	74.00	290.19	30.00	19.52	74.00	
	Heat	SU with pre-evap blank, large post-evap blank, discharge plenum (B,L,R,T)	343.19	30.00	19.52	74.00	343.19	30.00	19.52	74.00	
		SU with 4 in. vertical filter, discharge through heat section (B,L)	190.85	40.00	26.51	60.00	-	-	-	-	
		SU, discharge through heat section (B,L)	207.85	40.00	26.51	60.00	-	-	-	-	
		SU with pre-evap blank, discharge through heat section (B,L)	260.85	40.00	26.51	60.00	-	-	-	-	
		SU with heat, discharge plenum (B,L,R,T)	256.19	30.00	19.52	74.00	256.19	30.00	19.52	74.00	
		SU with pre-evap blank, heat, discharge plenum (B,L,R,T)	309.19	30.00	19.52	74.00	309.19	30.00	19.52	74.00	
		SU with heat, small post-evap blank, discharge plenum (B,L,R,T)	301.19	30.00	19.52	74.00	301.19	30.00	19.52	74.00	
		SU with pre-evap blank, heat, small post-evap blank, discharge plenum (B,L,R,T)	354.19	30.00	19.52	74.00	354.19	30.00	19.52	74.00	
	Standard economizer - no ERW	No heat - 55 in. supply fan	SU with heat, large post-evap blank, discharge plenum (B,L,R,T)	343.19	30.00	19.52	74.00	343.19	30.00	19.52	74.00
			SU with pre-evap blank, heat, large post-evap blank, discharge plenum (B,L,R,T)	396.19	30.00	19.52	74.00	396.19	30.00	19.52	74.00
			SU with 4 in. vertical filter, discharge plenum (B,L,R,T)	191.19	30.00	19.52	74.00	191.19	30.00	19.52	74.00
SU with discharge plenum (B,L,R,T)			208.19	30.00	19.52	74.00	208.19	30.00	19.52	74.00	
SU with small post-evap blank, discharge plenum (B,L,R,T)			253.19	30.00	19.52	74.00	253.19	30.00	19.52	74.00	
No heat - 74 in. supply fan		SU with pre-evap blank, small post-evap blank, discharge plenum (B,L,R,T)	306.19	30.00	19.52	74.00	306.19	30.00	19.52	74.00	
		SU with large post-evap blank, discharge plenum (B,L,R,T)	295.19	30.00	19.52	74.00	295.19	30.00	19.52	74.00	
		SU with pre-evap blank, large post-evap blank, discharge plenum (B,L,R,T)	348.19	30.00	19.52	74.00	348.19	30.00	19.52	74.00	
		SU with small post-evap blank, discharge plenum (B,L,R,T)	272.19	30.00	19.52	74.00	272.19	30.00	19.52	74.00	
Heat		SU with pre-evap blank, small post-evap blank, discharge plenum (B,L,R,T)	325.19	30.00	19.52	74.00	325.19	30.00	19.52	74.00	
		SU with large post-evap blank, discharge plenum (B,L,R,T)	314.19	30.00	19.52	74.00	314.19	30.00	19.52	74.00	
		SU with pre-evap blank, large post-evap blank, discharge plenum (B,L,R,T)	367.19	30.00	19.52	74.00	367.19	30.00	19.52	74.00	
	SU with 4 in. vertical filter, discharge through heat section (B,L)	214.85	40.00	26.51	60.00	-	-	-	-		
	SU, discharge through heat section (B,L)	231.85	40.00	26.51	60.00	-	-	-	-		
	SU with pre-evap blank, discharge through heat section (B,L)	284.85	40.00	26.51	60.00	-	-	-	-		
	SU with heat, discharge plenum (B,L,R,T)	280.19	30.00	19.52	74.00	280.19	30.00	19.52	74.00		
	SU with pre-evap blank, heat, discharge plenum (B,L,R,T)	333.19	30.00	19.52	74.00	333.19	30.00	19.52	74.00		
SU with heat, small post-evap blank, discharge plenum (B,L,R,T)	325.19	30.00	19.52	74.00	325.19	30.00	19.52	74.00			
Heat	SU with pre-evap blank, heat, small post-evap blank, discharge plenum (B,L,R,T)	378.19	30.00	19.52	74.00	378.19	30.00	19.52	74.00		
	SU with heat, large post-evap blank, discharge plenum (B,L,R,T)	367.19	30.00	19.52	74.00	367.19	30.00	19.52	74.00		
	SU with pre-evap blank, heat, large post-evap blank, discharge plenum (B,L,R,T)	420.19	30.00	19.52	74.00	420.19	30.00	19.52	74.00		
	SU with heat, large post-evap blank, discharge plenum (B,L,R,T)	420.19	30.00	19.52	74.00	420.19	30.00	19.52	74.00		

**Table 219: 60 ton unit dimensions (in.) with bottom and top discharge**

		Unit configuration	Bottom discharge				Top discharge			
			G	L4	I	W3	G	L4	I	W3
Standard economizer - ERW	No heat - 55 in. supply fan	SU with small post-evap blank, discharge plenum (B,L,R,T)	334.19	30.00	19.52	74.00	334.19	30.00	19.52	74.00
		SU with pre-evap blank, small post-evap blank, discharge plenum (B,L,R,T)	387.19	30.00	19.52	74.00	387.19	30.00	19.52	74.00
		SU with large post-evap blank, discharge plenum (B,L,R,T)	376.19	30.00	19.52	74.00	376.19	30.00	19.52	74.00
		SU with pre-evap blank, large post-evap blank, discharge plenum (B,L,R,T)	429.19	30.00	19.52	74.00	429.19	30.00	19.52	74.00
	No heat - 74 in. supply fan	SU with small post-evap blank, discharge plenum (B,L,R,T)	353.19	30.00	19.52	74.00	353.19	30.00	19.52	74.00
		SU with pre-evap blank, small post-evap blank, discharge plenum (B,L,R,T)	406.19	30.00	19.52	74.00	406.19	30.00	19.52	74.00
		SU with large post-evap blank, discharge plenum (B,L,R,T)	395.19	30.00	19.52	74.00	395.19	30.00	19.52	74.00
		SU with pre-evap blank, large post-evap blank, discharge plenum (B,L,R,T)	448.19	30.00	19.52	74.00	448.19	30.00	19.52	74.00
	Heat	SU, discharge through heat section (B,L)	312.85	40.00	26.51	60.00	-	-	-	-
		SU with pre-evap blank, discharge through heat section (B,L)	365.85	40.00	26.51	60.00	-	-	-	-
		SU with heat, discharge plenum (B,L,R,T)	361.19	30.00	19.52	74.00	361.19	30.00	19.52	74.00
		SU with pre-evap blank, heat, discharge plenum (B,L,R,T)	414.19	30.00	19.52	74.00	414.19	30.00	19.52	74.00
		SU with heat, small post-evap blank, discharge plenum (B,L,R,T)	406.19	30.00	19.52	74.00	406.19	30.00	19.52	74.00
		SU with pre-evap blank, heat, small post-evap blank, discharge plenum (B,L,R,T)	459.19	30.00	19.52	74.00	459.19	30.00	19.52	74.00
		SU with heat, large post-evap blank, discharge plenum (B,L,R,T)	448.19	30.00	19.52	74.00	448.19	30.00	19.52	74.00
		SU with pre-evap blank, heat, large post-evap blank, discharge plenum (B,L,R,T)	501.19	30.00	19.52	74.00	501.19	30.00	19.52	74.00

**Table 220: 60 ton unit dimensions (in.) with left and right discharge**

		Unit configuration	Left discharge				Right discharge			
			J	L2	K	H3	J	L2	K	H3
Basic economizer - no ERW	No heat - 55 in. supply fan	SU with 4 in. vertical filter, discharge plenum (B,L,R,T)	168.06	28.21	4.65	72.04	168.06	28.21	4.65	72.04
		SU with discharge plenum (B,L,R,T)	185.06	28.21	4.65	72.04	185.06	28.21	4.65	72.04
		SU with small post-evap blank, discharge plenum (B,L,R,T)	230.06	28.21	4.65	72.04	230.06	28.21	4.65	72.04
		SU with pre-evap blank, small post-evap blank, discharge plenum (B,L,R,T)	283.06	28.21	4.65	72.04	283.06	28.21	4.65	72.04
		SU with large post-evap blank, discharge plenum (B,L,R,T)	272.06	28.21	4.65	72.04	272.06	28.21	4.65	72.04
		SU with pre-evap blank, large post-evap blank, discharge plenum (B,L,R,T)	325.06	28.21	4.65	72.04	325.06	28.21	4.65	72.04
	No heat - 74 in. supply fan	SU with small post-evap blank, discharge plenum (B,L,R,T)	249.06	28.21	4.65	72.04	249.06	28.21	4.65	72.04
		SU with pre-evap blank, small post-evap blank, discharge plenum (B,L,R,T)	302.06	28.21	4.65	72.04	302.06	28.21	4.65	72.04
		SU with large post-evap blank, discharge plenum (B,L,R,T)	291.06	28.21	4.65	72.04	291.06	28.21	4.65	72.04
		SU with pre-evap blank, large post-evap blank, discharge plenum (B,L,R,T)	344.06	28.21	4.65	72.04	344.06	28.21	4.65	72.04
	Heat	SU with 4 in. vertical filter, discharge through heat section (B,L)	190.75	40.00	9.19	60.00	-	-	-	-
		SU, discharge through heat section (B,L)	207.75	40.00	9.19	60.00	-	-	-	-
		SU with pre-evap blank, discharge through heat section (B,L)	260.75	40.00	9.19	60.00	-	-	-	-
		SU with heat, discharge plenum (B,L,R,T)	257.06	28.21	4.65	72.04	257.06	28.21	4.65	72.04
		SU with pre-evap blank, heat, discharge plenum (B,L,R,T)	310.06	28.21	4.65	72.04	310.06	28.21	4.65	72.04
		SU with heat, small post-evap blank, discharge plenum (B,L,R,T)	302.06	28.21	4.65	72.04	302.06	28.21	4.65	72.04
		SU with pre-evap blank, heat, small post-evap blank, discharge plenum (B,L,R,T)	355.06	28.21	4.65	72.04	355.06	28.21	4.65	72.04
		SU with heat, large post-evap blank, discharge plenum (B,L,R,T)	344.06	28.21	4.65	72.04	344.06	28.21	4.65	72.04
	SU with pre-evap blank, heat, large post-evap blank, discharge plenum (B,L,R,T)	397.06	28.21	4.65	72.04	397.06	28.21	4.65	72.04	

**Table 220: 60 ton unit dimensions (in.) with left and right discharge**

		Unit configuration	Left discharge				Right discharge				
			J	L2	K	H3	J	L2	K	H3	
Standard economizer - no ERW	No heat - 55 in. supply fan	SU with 4 in. vertical filter, discharge plenum (B,L,R,T)	192.06	28.21	4.65	72.04	192.06	28.21	4.65	72.04	
		SU with discharge plenum (B,L,R,T)	209.06	28.21	4.65	72.04	209.06	28.21	4.65	72.04	
		SU with small post-evap blank, discharge plenum (B,L,R,T)	254.06	28.21	4.65	72.04	254.06	28.21	4.65	72.04	
		SU with pre-evap blank, small post-evap blank, discharge plenum (B,L,R,T)	307.06	28.21	4.65	72.04	307.06	28.21	4.65	72.04	
		SU with large post-evap blank, discharge plenum (B,L,R,T)	296.06	28.21	4.65	72.04	296.06	28.21	4.65	72.04	
		SU with pre-evap blank, large post-evap blank, discharge plenum (B,L,R,T)	349.06	28.21	4.65	72.04	349.06	28.21	4.65	72.04	
	No heat - 74 in. supply fan	SU with small post-evap blank, discharge plenum (B,L,R,T)	273.06	28.21	4.65	72.04	273.06	28.21	4.65	72.04	
		SU with pre-evap blank, small post-evap blank, discharge plenum (B,L,R,T)	326.06	28.21	4.65	72.04	326.06	28.21	4.65	72.04	
		SU with large post-evap blank, discharge plenum (B,L,R,T)	315.06	28.21	4.65	72.04	315.06	28.21	4.65	72.04	
	Heat	SU with pre-evap blank, large post-evap blank, discharge plenum (B,L,R,T)	368.06	28.21	4.65	72.04	368.06	28.21	4.65	72.04	
		SU with 4 in. vertical filter, discharge through heat section (B,L)	214.75	40.00	9.19	60.00	-	-	-	-	
		SU, discharge through heat section (B,L)	231.75	40.00	9.19	60.00	-	-	-	-	
		SU with pre-evap blank, discharge through heat section (B,L)					-	-	-	-	
		SU with heat, discharge plenum (B,L,R,T)	281.06	28.21	4.65	72.04	281.06	28.21	4.65	72.04	
		SU with pre-evap blank, heat, discharge plenum (B,L,R,T)	334.06	28.21	4.65	72.04	334.06	28.21	4.65	72.04	
		SU with heat, small post-evap blank, discharge plenum (B,L,R,T)	326.06	28.21	4.65	72.04	326.06	28.21	4.65	72.04	
		SU with pre-evap blank, heat, small post-evap blank, discharge plenum (B,L,R,T)	379.06	28.21	4.65	72.04	379.06	28.21	4.65	72.04	
	Standard economizer - ERW	No heat - 55 in. supply fan	SU with heat, large post-evap blank, discharge plenum (B,L,R,T)	368.06	28.21	4.65	72.04	368.06	28.21	4.65	72.04
			SU with pre-evap blank, heat, large post-evap blank, discharge plenum (B,L,R,T)	421.06	28.21	4.65	72.04	421.06	28.21	4.65	72.04
			SU with small post-evap blank, discharge plenum (B,L,R,T)	335.06	28.21	4.65	72.04	335.06	28.21	4.65	72.04
SU with pre-evap blank, small post-evap blank, discharge plenum (B,L,R,T)			388.06	28.21	4.65	72.04	388.06	28.21	4.65	72.04	
No heat - 74 in. supply fan		SU with large post-evap blank, discharge plenum (B,L,R,T)	377.06	28.21	4.65	72.04	377.06	28.21	4.65	72.04	
		SU with pre-evap blank, large post-evap blank, discharge plenum (B,L,R,T)	430.06	28.21	4.65	72.04	430.06	28.21	4.65	72.04	
		SU with small post-evap blank, discharge plenum (B,L,R,T)	354.06	28.21	4.65	72.04	354.06	28.21	4.65	72.04	
		SU with pre-evap blank, small post-evap blank, discharge plenum (B,L,R,T)	407.06	28.21	4.65	72.04	407.06	28.21	4.65	72.04	
		SU with large post-evap blank, discharge plenum (B,L,R,T)	396.06	28.21	4.65	72.04	396.06	28.21	4.65	72.04	
		SU with pre-evap blank, large post-evap blank, discharge plenum (B,L,R,T)	449.06	28.21	4.65	72.04	449.06	28.21	4.65	72.04	
Heat	SU, discharge through heat section (B,L)	312.85	40.00	9.19	60.00	-	-	-	-		
	SU with pre-evap blank, discharge through heat section (B,L)	365.85	40.00	9.19	60.00	-	-	-	-		
	SU with heat, discharge plenum (B,L,R,T)	362.06	28.21	4.65	72.04	362.06	28.21	4.65	72.04		
	SU with pre-evap blank, heat, discharge plenum (B,L,R,T)	415.06	28.21	4.65	72.04	415.06	28.21	4.65	72.04		
	SU with heat, small post-evap blank, discharge plenum (B,L,R,T)	407.06	28.21	4.65	72.04	407.06	28.21	4.65	72.04		
	SU with pre-evap blank, heat, small post-evap blank, discharge plenum (B,L,R,T)	460.06	28.21	4.65	72.04	460.06	28.21	4.65	72.04		
	SU with heat, large post-evap blank, discharge plenum (B,L,R,T)	449.06	28.21	4.65	72.04	449.06	28.21	4.65	72.04		
	SU with pre-evap blank, heat, large post-evap blank, discharge plenum (B,L,R,T)	502.06	28.21	4.65	72.04	502.06	28.21	4.65	72.04		

**Note:**

1. A SU includes length for economizer, draw-through filter, cooling coil, supply fan, and condenser. A SU includes a draw-through (pre-evaporator) filter with 2 in. angle filter or 2 in. + 12 in. (or 18 in.) filter. Units with a vertical 4 in. draw-through filter in place of the standard 2 in. angle or 2 in. + 12 in. (or 18 in.) filter are listed as *SU with Vertical Filter 4 in.*
2. Basic economizer unit does not include an exhaust fan or return fan option.
3. The heat section includes either gas, hot water, steam, or electric.
4. SU = Standard Unit, DP = Discharge Plenum, B = Bottom Discharge, L = Left Discharge, R = Right Discharge, T = Top Discharge.
5. Dimensions are ± 1 in..
6. For units that are shipped split, please contact your local sales office or use the Selection Navigator to get the individual air handler and condenser unit lengths.

**Figure 18: 70 ton to 80 ton dimensional drawing**

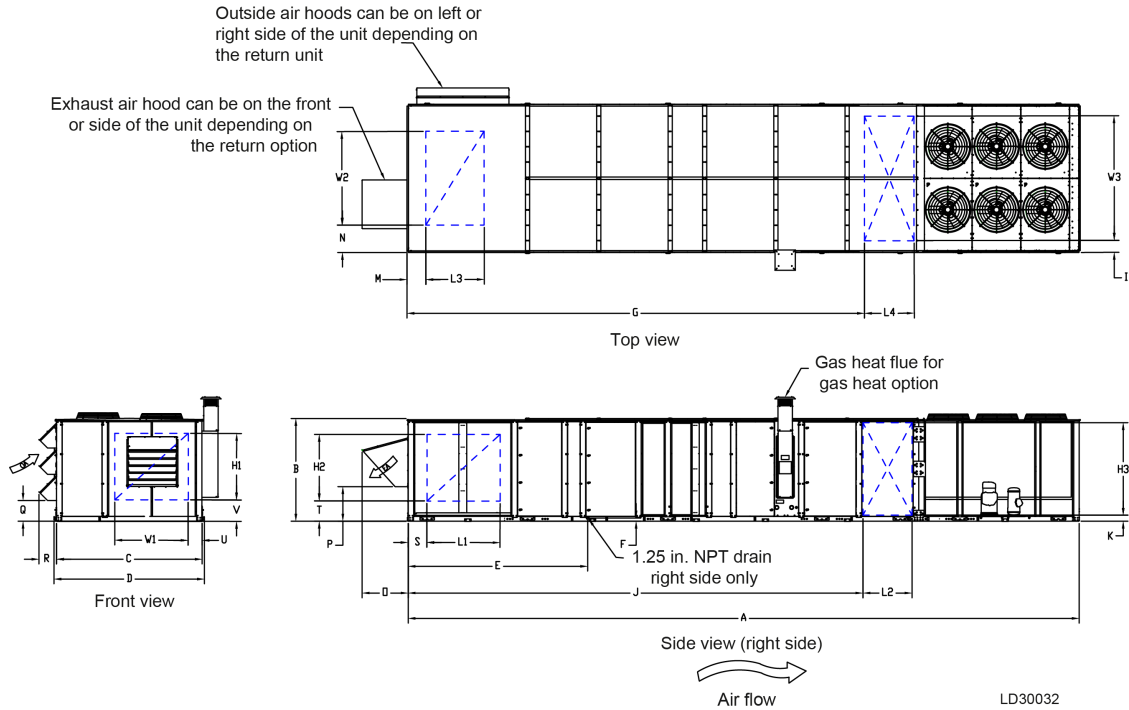

**Table 221: 70 ton to 80 ton unit dimensions (in.) for return options with an ERW**

Unit configuration	ERW only available with an exhaust fan with backdraft damper or modulating damper							
	M	L3	W2	N	O	P	Q	R
Bottom return, right OA, side exhaust	111.48	72.92	54.50	54.42	26.71	22.48	16.17	13.93
Bottom return, right OA, front exhaust	111.48	72.92	54.50	54.42	26.71	22.48	16.17	13.93

**Table 222: 70 ton to 80 ton unit dimensions (in.) for return options without an ERW**

Unit configuration	If unit has a return fan with modulating damper								If unit has an exhaust fan with backdraft damper or modulating damper							
	M	L3	W2	N	O	P	Q	R	M	L3	W2	N	O	P	Q	R
Bottom return, right OA, side exhaust	13.66	41.63	45.51	54.71	52.68	13.07	16.17	13.93	13.66	56.94	71.31	31.05	35.95	26.92	16.17	13.93
Bottom return, right OA, front exhaust	13.66	41.63	45.51	54.71	52.68	13.07	16.17	13.93	13.66	56.91	77.87	31.05	35.95	26.92	16.17	13.93
Bottom return, left OA, side exhaust	13.66	41.63	45.51	12.83	52.68	13.07	16.17	13.93	13.66	56.91	71.31	10.67	35.95	26.92	16.17	13.93
Bottom return, left OA, front exhaust	13.66	41.63	45.51	12.83	52.68	13.07	16.17	13.93	13.66	56.91	77.87	4.13	35.95	26.92	16.17	13.93
Top return, right OA, side exhaust	-	-	-	-	-	-	-	-	3.23	49.30	82.59	28.70	35.95	26.92	16.17	13.93
Top return, right OA, front exhaust	-	-	-	-	-	-	-	-	3.23	49.30	82.59	28.70	35.95	26.92	16.17	13.93
Top return, left OA, side exhaust	-	-	-	-	-	-	-	-	3.23	49.30	82.59	1.76	35.95	26.92	16.17	13.93
Top return, left OA, front exhaust	-	-	-	-	-	-	-	-	3.23	49.30	82.59	1.76	35.95	26.92	16.17	13.93
<b>Dimension set</b>	<b>S</b>	<b>L1</b>	<b>H2</b>	<b>T</b>	<b>O</b>	<b>P</b>	<b>Q</b>	<b>R</b>	<b>S</b>	<b>L1</b>	<b>H2</b>	<b>T</b>	<b>O</b>	<b>P</b>	<b>Q</b>	<b>R</b>
Left return, right OA, front exhaust	18.99	47	47	10.34	52.68	13.07	16.17	13.93	5.09	74.78	66.11	7.64	35.95	26.92	16.17	13.93
Right return, left OA, front exhaust	18.99	47	47	10.34	52.68	13.07	16.17	13.93	5.09	74.78	66.11	7.64	35.95	26.92	16.17	13.93
<b>Dimension set</b>	<b>U</b>	<b>W1</b>	<b>H1</b>	<b>V</b>	<b>O</b>	<b>P</b>	<b>Q</b>	<b>R</b>	<b>U</b>	<b>W1</b>	<b>H1</b>	<b>V</b>	<b>O</b>	<b>P</b>	<b>Q</b>	<b>R</b>
Front return, left OA, right exhaust	12.80	47	47	10.34	52.68	13.07	16.17	13.93	5.09	62.40	66.10	7.64	35.95	26.92	16.17	13.93
Front return, right OA, left exhaust	53.25	47	47	10.34	52.68	13.07	16.17	13.93	45.56	62.40	66.10	7.64	35.95	26.92	16.17	13.93

Unit configuration	If unit has no fan and barometric damper							
	M	L3	W2	N	O	P	Q	R
Bottom return, right OA, side exhaust	6.13	54.28	65.00	43.92	38.08	20.58	11.27	13.93
Bottom return, right OA, front exhaust	6.13	54.28	65.00	43.92	38.08	20.58	11.27	13.93
Bottom return, left OA, side exhaust	6.13	54.28	65.00	4.13	38.08	20.58	11.27	13.93
Bottom return, left OA, front exhaust	6.13	54.28	65.00	4.13	38.08	20.58	11.27	13.93

Unit configuration	If unit has no fan and barometric damper							
Bottom return, no OA, no EA	6.13	54.28	65.00	43.92	-	-	-	-
Top return, right OA, side exhaust	3.23	49.30	71.29	40.01	38.08	20.58	11.27	17.46
Top return, right OA, front exhaust	3.23	49.30	71.29	40.01	38.08	20.58	11.27	17.46
Top return, left OA, side exhaust	3.23	49.30	71.29	1.76	38.08	20.58	11.27	17.46
Top return, left OA, front exhaust	3.23	49.30	71.29	1.76	38.08	20.58	11.27	17.46
Top return, no OA, no EA	3.23	49.30	71.29	40.01	-	-	-	-
<b>Dimension set</b>	<b>S</b>	<b>L1</b>	<b>H2</b>	<b>T</b>	<b>O</b>	<b>P</b>	<b>Q</b>	<b>R</b>
Left return, right OA, front exhaust	5.09	50.78	66.05	7.67	38.08	20.58	11.27	13.93
Left return, no OA, no EA	5.09	50.78	66.05	7.67	-	-	-	-
Right return, left OA, front exhaust	5.09	50.78	66.04	7.67	38.08	20.58	11.27	17.46
Right return, no OA, no EA	5.09	50.78	66.04	7.67	-	-	-	-
<b>Dimension set</b>	<b>U</b>	<b>W1</b>	<b>H1</b>	<b>V</b>	<b>O</b>	<b>P</b>	<b>Q</b>	<b>R</b>
Front return, left OA, right exhaust	5.09	62.40	66.10	7.64	38.08	20.58	11.27	17.46
Front return, right OA, left exhaust	45.56	62.40	66.10	7.64	38.08	20.58	11.27	17.46
Front return, no OA, no EA	45.56	62.40	66.10	7.64	-	-	-	-

**Table 223: 70 ton to 80 ton unit dimensions (in.)**

		Unit configuration	Unit length (A)	Unit height (B)	Unit width (C)	Unit width lifting lug to lifting lug (D)	Evaporator or drain length (E)	Evaporator drain height (F)
Basic economizer - no ERW	No heat - 55 in. supply fan	SU with 4 in. vertical filter, discharge plenum (B,L,R,T)	365.04	80.00	113.36	117.00	98.80	2.50
		SU with discharge plenum (B,L,R,T)	382.04	80.00	113.36	117.00	115.80	2.50
		SU with small post-evap blank, discharge plenum (B,L,R,T)	427.04	80.00	113.36	117.06	115.80	2.50
		SU with pre-evap blank, small post-evap blank, discharge plenum (B,L,R,T)	480.04	80.00	113.36	117.06	168.80	2.50
		SU with large post-evap blank, discharge plenum (B,L,R,T)	469.04	80.00	113.36	117.06	115.80	2.50
	No heat - 74 in. supply fan	SU with pre-evap blank, large post-evap blank, discharge plenum (B,L,R,T)	522.04	80.00	113.36	117.06	168.80	2.50
		SU with small post-evap blank, discharge plenum (B,L,R,T)	446.04	80.00	113.36	117.00	115.80	2.50
		SU with pre-evap blank, small post-evap blank, discharge plenum (B,L,R,T)	499.04	80.00	113.36	117.06	168.80	2.50
		SU with large post-evap blank, discharge plenum (B,L,R,T)	488.04	80.00	113.36	117.06	115.80	2.50
	Heat	SU with pre-evap blank, large post-evap blank, discharge plenum (B,L,R,T)	541.04	80.00	113.36	117.06	168.80	2.50
		SU with 4 in. vertical filter, discharge through heat section (B,L)	391.04	80.00	113.36	117.00	98.80	2.50
		SU, discharge through heat section (B,L)	408.04	80.00	113.36	117.00	115.80	2.50
		SU with pre-evap blank, discharge through heat section (B,L)	461.04	80.00	113.36	117.06	168.8	2.50
		SU with heat, discharge plenum (B,L,R,T)	454.04	80.00	113.36	117.00	115.80	2.50
		SU with pre-evap blank, heat, discharge plenum (B,L,R,T)	507.04	80.00	113.36	117.06	168.8	2.50
		SU with heat, small post-evap blank, discharge plenum (B,L,R,T)	499.04	80.00	113.36	117.00	115.80	2.50
		SU with pre-evap blank, heat, small post-evap blank, discharge plenum (B,L,R,T)	552.04	80.00	113.36	117.06	168.8	2.50
	SU with heat, large post-evap blank, discharge plenum (B,L,R,T)	541.04	80.00	113.36	117.06	115.80	2.50	
	SU with pre-evap blank, heat, large post-evap blank, discharge plenum (B,L,R,T)	594.04	80.00	113.36	117.06	168.8	2.50	

**Table 223: 70 ton to 80 ton unit dimensions (in.)**

		Unit configuration	Unit length (A)	Unit height (B)	Unit width (C)	Unit width lifting lug to lifting lug (D)	Evaporator or drain length (E)	Evaporator drain height (F)	
Standard economizer - no ERW	No heat - 55 in. supply fan	SU with 4 in. vertical filter, discharge plenum (B,L,R,T)	389.04	80.00	113.36	117.00	122.80	2.50	
		SU with discharge plenum (B,L,R,T)	406.04	80.00	113.36	117.00	139.80	2.50	
		SU with small post-evap blank, discharge plenum (B,L,R,T)	451.04	80.00	113.36	117.06	139.80	2.50	
		SU with pre-evap blank, small post-evap blank, discharge plenum (B,L,R,T)	504.04	80.00	113.36	117.06	192.80	2.50	
		SU with large post-evap blank, discharge plenum (B,L,R,T)	493.04	80.00	113.36	117.06	139.80	2.50	
		SU with pre-evap blank, large post-evap blank, discharge plenum (B,L,R,T)	546.04	80.00	113.36	117.06	192.80	2.50	
	No heat - 74 in. supply fan	SU with small post-evap blank, discharge plenum (B,L,R,T)	470.04	80.00	113.36	117.00	139.80	2.50	
		SU with pre-evap blank, small post-evap blank, discharge plenum (B,L,R,T)	523.04	80.00	113.36	117.06	192.80	2.50	
		SU with large post-evap blank, discharge plenum (B,L,R,T)	512.04	80.00	113.36	117.06	139.80	2.50	
		SU with pre-evap blank, large post-evap blank, discharge plenum (B,L,R,T)	565.04	80.00	113.36	117.06	192.80	2.50	
	Heat	SU with 4 in. vertical filter, discharge through heat section (B,L)	415.04	80.00	113.36	117.00	122.80	2.50	
		SU, discharge through heat section (B,L)	432.04	80.00	113.36	117.00	139.80	2.50	
		SU with pre-evap blank, discharge through heat section (B,L)	485.04	80.00	113.36	117.06	192.80	2.50	
		SU with heat, discharge plenum (B,L,R,T)	478.04	80.00	113.36	117.00	139.80	2.50	
		SU with pre-evap blank, heat, discharge plenum (B,L,R,T)	531.04	80.00	113.36	117.06	192.80	2.50	
		SU with heat, small post-evap blank, discharge plenum (B,L,R,T)	523.04	80.00	113.36	117.00	139.80	2.50	
		SU with pre-evap blank, heat, small post-evap blank, discharge plenum (B,L,R,T)	576.04	80.00	113.36	117.06	192.80	2.50	
		SU with heat, large post-evap blank, discharge plenum (B,L,R,T)	565.04	80.00	113.36	117.06	139.80	2.50	
	SU with pre-evap blank, heat, large post-evap blank, discharge plenum (B,L,R,T)	618.04	80.00	113.36	117.06	192.80	2.50		
	Standard economizer - ERW	No heat - 55 in. supply fan	SU with small post-evap blank, discharge plenum (B,L,R,T)	551.04	80.00	113.36	117.06	239.80	2.50
			SU with pre-evap blank, small post-evap blank, discharge plenum (B,L,R,T)	604.04	80.00	113.36	117.06	292.80	2.50
			SU with large post-evap blank, discharge plenum (B,L,R,T)	593.04	80.00	113.36	117.06	239.80	2.50
			SU with pre-evap blank, large post-evap blank, discharge plenum (B,L,R,T)	646.04	80.00	113.36	117.06	292.80	2.50
		No heat - 74 in. supply fan	SU with small post-evap blank, discharge plenum (B,L,R,T)	570.04	80.00	113.36	117.06	239.80	2.50
SU with pre-evap blank, small post-evap blank, discharge plenum (B,L,R,T)			623.04	80.00	113.36	117.06	292.80	2.50	
SU with large post-evap blank, discharge plenum (B,L,R,T)			612.04	80.00	113.36	117.06	239.80	2.50	
SU with pre-evap blank, large post-evap blank, discharge plenum (B,L,R,T)			665.04	80.00	113.36	117.06	292.80	2.50	
Heat		SU, discharge through heat section (B,L)	532.04	80.00	113.36	117.06	239.80	2.50	
		SU with pre-evap blank, discharge through heat section (B,L)	585.04	80.00	113.36	117.06	292.80	2.50	
		SU with heat, discharge plenum (B,L,R,T)	578.04	80.00	113.36	117.06	239.80	2.50	
		SU with pre-evap blank, heat, discharge plenum (B,L,R,T)	631.04	80.00	113.36	117.06	292.80	2.50	
		SU with heat, small post-evap blank, discharge plenum (B,L,R,T)	623.04	80.00	113.36	117.06	239.80	2.50	
		SU with pre-evap blank, heat, small post-evap blank, discharge plenum (B,L,R,T)	676.04	80.00	113.36	117.06	292.80	2.50	
		SU with heat, large post-evap blank, discharge plenum (B,L,R,T)	665.04	80.00	113.36	117.06	239.80	2.50	
		SU with pre-evap blank, heat, large post-evap blank, discharge plenum (B,L,R,T)	718.04	80.00	113.36	117.06	292.80	2.50	

**Table 224: 70 ton to 80 ton unit dimensions (in.) with bottom and top discharge**

		Unit configuration	Bottom discharge				Top discharge			
			G	L4	I	W3	G	L4	I	W3
Basic economizer - no ERW	No heat - 55 in. supply fan	SU with 4 in. vertical filter, discharge plenum (B,L,R,T)	195.69	40.00	19.52	74.00	195.69	40.00	19.52	74.00
		SU with discharge plenum (B,L,R,T)	212.69	40.00	19.52	74.00	212.69	40.00	19.52	74.00
		SU with small post-evap blank, discharge plenum (B,L,R,T)	257.69	40.00	19.52	74.00	257.69	40.00	19.52	74.00
		SU with pre-evap blank, small post-evap blank, discharge plenum (B,L,R,T)	310.69	40.00	19.52	74.00	310.69	40.00	19.52	74.00
		SU with large post-evap blank, discharge plenum (B,L,R,T)	299.69	40.00	19.52	74.00	299.69	40.00	19.52	74.00
	No heat - 74 in. supply fan	SU with pre-evap blank, large post-evap blank, discharge plenum (B,L,R,T)	352.69	40.00	19.52	74.00	352.69	40.00	19.52	74.00
		SU with small post-evap blank, discharge plenum (B,L,R,T)	276.69	40.00	19.52	74.00	276.69	40.00	19.52	74.00
		SU with pre-evap blank, small post-evap blank, discharge plenum (B,L,R,T)	329.69	40.00	19.52	74.00	329.69	40.00	19.52	74.00
		SU with large post-evap blank, discharge plenum (B,L,R,T)	318.69	40.00	19.52	74.00	318.69	40.00	19.52	74.00
		SU with pre-evap blank, large post-evap blank, discharge plenum (B,L,R,T)	371.69	40.00	19.52	74.00	371.69	40.00	19.52	74.00
	Heat	SU with 4 in. vertical filter, discharge through heat section (B,L)	219.35	40.00	26.50	60.00	-	-	-	-
		SU, discharge through heat section (B,L)	236.35	40.00	26.50	60.00	-	-	-	-
		SU with pre-evap blank, discharge through heat section (B,L)	289.35	40.00	26.50	60.00	-	-	-	-
		SU with heat, discharge plenum (B,L,R,T)	284.69	40.00	19.52	74.00	284.69	40.00	19.52	74.00
		SU with pre-evap blank, heat, discharge plenum (B,L,R,T)	337.69	40.00	19.52	74.00	337.69	40.00	19.52	74.00
		SU with heat, small post-evap blank, discharge plenum (B,L,R,T)	329.69	40.00	19.52	74.00	329.69	40.00	19.52	74.00
		SU with pre-evap blank, heat, small post-evap blank, discharge plenum (B,L,R,T)	382.69	40.00	19.52	74.00	382.69	40.00	19.52	74.00
		SU with heat, large post-evap blank, discharge plenum (B,L,R,T)	371.69	40.00	19.52	74.00	371.69	40.00	19.52	74.00
	SU with pre-evap blank, heat, large post-evap blank, discharge plenum (B,L,R,T)	424.69	40.00	19.52	74.00	424.69	40.00	19.52	74.00	
	Standard economizer - no ERW	No heat - 55 in. supply fan	SU with 4 in. vertical filter, discharge plenum (B,L,R,T)	219.69	40.00	19.52	74.00	219.69	40.00	19.52
SU with discharge plenum (B,L,R,T)			236.69	40.00	19.52	74.00	236.69	40.00	19.52	74.00
SU with small post-evap blank, discharge plenum (B,L,R,T)			281.69	40.00	19.52	74.00	281.69	40.00	19.52	74.00
SU with pre-evap blank, small post-evap blank, discharge plenum (B,L,R,T)			334.69	40.00	19.52	74.00	334.69	40.00	19.52	74.00
SU with large post-evap blank, discharge plenum (B,L,R,T)			323.69	40.00	19.52	74.00	323.69	40.00	19.52	74.00
No heat - 74 in. supply fan		SU with pre-evap blank, large post-evap blank, discharge plenum (B,L,R,T)	376.69	40.00	19.52	74.00	376.69	40.00	19.52	74.00
		SU with small post-evap blank, discharge plenum (B,L,R,T)	300.69	40.00	19.52	74.00	300.69	40.00	19.52	74.00
		SU with pre-evap blank, small post-evap blank, discharge plenum (B,L,R,T)	353.69	40.00	19.52	74.00	353.69	40.00	19.52	74.00
		SU with large post-evap blank, discharge plenum (B,L,R,T)	342.69	40.00	19.52	74.00	342.69	40.00	19.52	74.00
		SU with pre-evap blank, large post-evap blank, discharge plenum (B,L,R,T)	395.69	40.00	19.52	74.00	395.69	40.00	19.52	74.00
Heat		SU with 4 in. vertical filter, discharge through heat section (B,L)	243.35	40.00	26.50	60.00	-	-	-	-
		SU, discharge through heat section (B,L)	260.35	40.00	26.50	60.00	-	-	-	-
		SU with pre-evap blank, discharge through heat section (B,L)	313.35	40.00	26.50	60.00	-	-	-	-
		SU with heat, discharge plenum (B,L,R,T)	308.69	40.00	19.52	74.00	308.69	40.00	19.52	74.00
		SU with pre-evap blank, heat, discharge plenum (B,L,R,T)	361.69	40.00	19.52	74.00	361.69	40.00	19.52	74.00
		SU with heat, small post-evap blank, discharge plenum (B,L,R,T)	353.69	40.00	19.52	74.00	353.69	40.00	19.52	74.00
		SU with pre-evap blank, heat, small post-evap blank, discharge plenum (B,L,R,T)	406.69	40.00	19.52	74.00	406.69	40.00	19.52	74.00
		SU with heat, large post-evap blank, discharge plenum (B,L,R,T)	395.69	40.00	19.52	74.00	395.69	40.00	19.52	74.00
SU with pre-evap blank, heat, large post-evap blank, discharge plenum (B,L,R,T)		448.69	40.00	19.52	74.00	448.69	40.00	19.52	74.00	

**Table 224: 70 ton to 80 ton unit dimensions (in.) with bottom and top discharge**

		Unit configuration	Bottom discharge				Top discharge			
			G	L4	I	W3	G	L4	I	W3
Standard economizer - ERW	No heat - 55 in. supply fan	SU with small post-evap blank, discharge plenum (B,L,R,T)	381.69	40.00	19.52	74.00	281.69	40.00	19.52	74.00
		SU with pre-evap blank, small post-evap blank, discharge plenum (B,L,R,T)	434.69	40.00	19.52	74.00	334.69	40.00	19.52	74.00
		SU with large post-evap blank, discharge plenum (B,L,R,T)	423.69	40.00	19.52	74.00	323.69	40.00	19.52	74.00
		SU with pre-evap blank, large post-evap blank, discharge plenum (B,L,R,T)	476.69	40.00	19.52	74.00	376.69	40.00	19.52	74.00
	No heat - 74 in. supply fan	SU with small post-evap blank, discharge plenum (B,L,R,T)	400.69	40.00	19.52	74.00	400.69	40.00	19.52	74.00
		SU with pre-evap blank, small post-evap blank, discharge plenum (B,L,R,T)	453.69	40.00	19.52	74.00	453.69	40.00	19.52	74.00
		SU with large post-evap blank, discharge plenum (B,L,R,T)	442.69	40.00	19.52	74.00	442.69	40.00	19.52	74.00
		SU with pre-evap blank, large post-evap blank, discharge plenum (B,L,R,T)	495.69	40.00	19.52	74.00	495.69	40.00	19.52	74.00
	Heat	SU, discharge through heat section (B,L)	360.35	40.00	26.50	60.00	-	-	-	-
		SU with pre-evap blank, discharge through heat section (B,L)	413.35	40.00	26.50	60.00	-	-	-	-
		SU with heat, discharge plenum (B,L,R,T)	408.35	40.00	26.50	60.00	408.35	40.00	26.50	60.00
		SU with pre-evap blank, heat, discharge plenum (B,L,R,T)	461.69	40.00	19.52	74.00	461.69	40.00	19.52	74.00
		SU with heat, small post-evap blank, discharge plenum (B,L,R,T)	453.69	40.00	19.52	74.00	453.69	40.00	19.52	74.00
		SU with pre-evap blank, heat, small post-evap blank, discharge plenum (B,L,R,T)	506.69	40.00	19.52	74.00	506.69	40.00	19.52	74.00
		SU with heat, large post-evap blank, discharge plenum (B,L,R,T)	495.69	40.00	19.52	74.00	495.69	40.00	19.52	74.00
		SU with pre-evap blank, heat, large post-evap blank, discharge plenum (B,L,R,T)	548.69	40.00	19.52	74.00	548.69	40.00	19.52	74.00

**Table 225: 70 ton to 80 ton unit dimensions (in.) with left and right discharge**

		Unit configuration	Left discharge				Right discharge			
			J	L2	K	H3	J	L2	K	H3
Basic economizer - no ERW	No heat - 55 in. supply fan	SU with 4 in. vertical filter, discharge plenum (B,L,R,T)	196.56	38.21	4.65	72.04	196.56	38.21	4.65	72.04
		SU with discharge plenum (B,L,R,T)	213.56	38.21	4.65	72.04	213.56	38.21	4.65	72.04
		SU with small post-evap blank, discharge plenum (B,L,R,T)	258.56	38.21	4.65	72.04	258.56	38.21	4.65	72.04
		SU with pre-evap blank, small post-evap blank, discharge plenum (B,L,R,T)	311.56	38.21	4.65	72.04	311.56	38.21	4.65	72.04
	No heat - 74 in. supply fan	SU with large post-evap blank, discharge plenum (B,L,R,T)	300.56	38.21	4.65	72.04	300.56	38.21	4.65	72.04
		SU with pre-evap blank, large post-evap blank, discharge plenum (B,L,R,T)	353.56	38.21	4.65	72.04	353.56	38.21	4.65	72.04
		SU with small post-evap blank, discharge plenum (B,L,R,T)	277.56	38.21	4.65	72.04	277.56	38.21	4.65	72.04
		SU with pre-evap blank, small post-evap blank, discharge plenum (B,L,R,T)	330.56	38.21	4.65	72.04	330.56	38.21	4.65	72.04
	No heat - 55 in. supply fan	SU with large post-evap blank, discharge plenum (B,L,R,T)	319.56	38.21	4.65	72.04	319.56	38.21	4.65	72.04
		SU with pre-evap blank, large post-evap blank, discharge plenum (B,L,R,T)	372.56	38.21	4.65	72.04	372.56	38.21	4.65	72.04
		SU with 4 in. vertical filter, discharge through heat section (B,L)	219.25	40.00	9.19	60.00	-	-	-	-
		SU, discharge through heat section (B,L)	236.25	40.00	9.19	60.00	-	-	-	-
	Heat	SU with pre-evap blank, discharge through heat section (B,L)	289.25	40.00	9.19	60.00	-	-	-	-
		SU with heat, discharge plenum (B,L,R,T)	285.56	38.21	4.65	72.04	285.56	38.21	4.65	72.04
		SU with pre-evap blank, heat, discharge plenum (B,L,R,T)	338.56	38.21	4.65	72.04	338.56	38.21	4.65	72.04
		SU with heat, small post-evap blank, discharge plenum (B,L,R,T)	330.56	38.21	4.65	72.04	330.56	38.21	4.65	72.04
		SU with pre-evap blank, heat, small post-evap blank, discharge plenum (B,L,R,T)	383.56	38.21	4.65	72.04	383.56	38.21	4.65	72.04
		SU with heat, large post-evap blank, discharge plenum (B,L,R,T)	372.56	38.21	4.65	72.04	372.56	38.21	4.65	72.04
		SU with pre-evap blank, heat, large post-evap blank, discharge plenum (B,L,R,T)	425.56	38.21	4.65	72.04	425.56	38.21	4.65	72.04

**Table 225: 70 ton to 80 ton unit dimensions (in.) with left and right discharge**

		Unit configuration	Left discharge				Right discharge				
			J	L2	K	H3	J	L2	K	H3	
Standard economizer - no ERW	No heat - 55 in. supply fan	SU with 4 in. vertical filter, discharge plenum (B,L,R,T)	220.56	38.21	4.65	72.04	220.56	38.21	4.65	72.04	
		SU with discharge plenum (B,L,R,T)	237.56	38.21	4.65	72.04	237.56	38.21	4.65	72.04	
		SU with small post-evap blank, discharge plenum (B,L,R,T)	282.56	38.21	4.65	72.04	282.56	38.21	4.65	72.04	
		SU with pre-evap blank, small post-evap blank, discharge plenum (B,L,R,T)	335.56	38.21	4.65	72.04	335.56	38.21	4.65	72.04	
		SU with large post-evap blank, discharge plenum (B,L,R,T)	324.56	38.21	4.65	72.04	324.56	38.21	4.65	72.04	
		SU with pre-evap blank, large post-evap blank, discharge plenum (B,L,R,T)	377.56	38.21	4.65	72.04	377.56	38.21	4.65	72.04	
	No heat - 74 in. supply fan	SU with small post-evap blank, discharge plenum (B,L,R,T)	301.56	38.21	4.65	72.04	301.56	38.21	4.65	72.04	
		SU with pre-evap blank, small post-evap blank, discharge plenum (B,L,R,T)	354.56	38.21	4.65	72.04	354.56	38.21	4.65	72.04	
		SU with large post-evap blank, discharge plenum (B,L,R,T)	343.56	38.21	4.65	72.04	343.56	38.21	4.65	72.04	
	Heat	SU with pre-evap blank, large post-evap blank, discharge plenum (B,L,R,T)	396.56	38.21	4.65	72.04	396.56	38.21	4.65	72.04	
		SU with 4 in. vertical filter, discharge through heat section (B,L)	243.25	40.00	9.19	60.00	-	-	-	-	
		SU, discharge through heat section (B,L)	260.25	40.00	9.19	60.00	-	-	-	-	
		SU with pre-evap blank, discharge through heat section (B,L)	313.25	40.00	9.19	60.00	-	-	-	-	
		SU with heat, discharge plenum (B,L,R,T)	309.56	38.21	4.65	72.04	309.56	38.21	4.65	72.04	
		SU with pre-evap blank, heat, discharge plenum (B,L,R,T)	362.56	38.21	4.65	72.04	362.56	38.21	4.65	72.04	
		SU with heat, small post-evap blank, discharge plenum (B,L,R,T)	354.56	38.21	4.65	72.04	354.56	38.21	4.65	72.04	
		SU with pre-evap blank, heat, small post-evap blank, discharge plenum (B,L,R,T)	407.56	38.21	4.65	72.04	407.56	38.21	4.65	72.04	
	Standard economizer - ERW	No heat - 55 in. supply fan	SU with heat, large post-evap blank, discharge plenum (B,L,R,T)	396.56	38.21	4.65	72.04	396.56	38.21	4.65	72.04
			SU with pre-evap blank, heat, large post-evap blank, discharge plenum (B,L,R,T)	449.56	38.21	4.65	72.04	449.56	38.21	4.65	72.04
			SU with small post-evap blank, discharge plenum (B,L,R,T)	282.56	38.21	4.65	72.04	282.56	38.21	4.65	72.04
			SU with pre-evap blank, small post-evap blank, discharge plenum (B,L,R,T)	335.56	38.21	4.65	72.04	335.56	38.21	4.65	72.04
No heat - 74 in. supply fan		SU with large post-evap blank, discharge plenum (B,L,R,T)	324.56	38.21	4.65	72.04	324.56	38.21	4.65	72.04	
		SU with pre-evap blank, large post-evap blank, discharge plenum (B,L,R,T)	377.56	38.21	4.65	72.04	377.56	38.21	4.65	72.04	
		SU with small post-evap blank, discharge plenum (B,L,R,T)	401.56	38.21	4.65	72.04	401.56	38.21	4.65	72.04	
Heat		SU with pre-evap blank, small post-evap blank, discharge plenum (B,L,R,T)	454.56	38.21	4.65	72.04	454.56	38.21	4.65	72.04	
		SU with large post-evap blank, discharge plenum (B,L,R,T)	443.56	38.21	4.65	72.04	443.56	38.21	4.65	72.04	
		SU with pre-evap blank, large post-evap blank, discharge plenum (B,L,R,T)	496.56	38.21	4.65	72.04	496.56	38.21	4.65	72.04	
	SU, discharge through heat section (B,L)	360.25	40.00	9.19	60.00	-	-	-	-		
	SU with pre-evap blank, discharge through heat section (B,L)	413.25	40.00	9.19	60.00	-	-	-	-		
	SU with heat, discharge plenum (B,L,R,T)	409.56	40.00	9.19	60.00	409.56	40.00	9.19	60.00		
	SU with pre-evap blank, heat, discharge plenum (B,L,R,T)	462.56	38.21	4.65	72.04	462.56	38.21	4.65	72.04		
SU with heat, small post-evap blank, discharge plenum (B,L,R,T)	454.56	38.21	4.65	72.04	454.56	38.21	4.65	72.04			
Heat	SU with pre-evap blank, heat, small post-evap blank, discharge plenum (B,L,R,T)	407.56	38.21	4.65	72.04	407.56	38.21	4.65	72.04		
	SU with heat, large post-evap blank, discharge plenum (B,L,R,T)	496.56	38.21	4.65	72.04	496.56	38.21	4.65	72.04		
	SU with pre-evap blank, heat, large post-evap blank, discharge plenum (B,L,R,T)	449.56	38.21	4.65	72.04	449.56	38.21	4.65	72.04		
	SU with heat, large post-evap blank, discharge plenum (B,L,R,T)	496.56	38.21	4.65	72.04	496.56	38.21	4.65	72.04		

**Note:**

1. A SU includes length for economizer, draw-through filter, cooling coil, supply fan, and condenser. A SU includes a draw-through (pre-evaporator) filter with 2 in. angle filter or 2 in. + 12 in. (or 18 in.) filter. Units with a vertical 4 in. draw-through filter in place of the standard 2 in. angle or 2 in. + 12 in. (or 18 in.) filter are listed as *SU with Vertical Filter 4 in.*
2. Basic economizer unit does not include an exhaust fan or return fan option.
3. The heat section includes either gas, hot water, steam, or electric.
4. SU = Standard Unit, DP = Discharge Plenum, B = Bottom Discharge, L = Left Discharge, R = Right Discharge, T = Top Discharge.
5. Dimensions are ± 1 in..
6. For units that are shipped split, please contact your local sales office or use the Selection Navigator to get the individual air handler and condenser unit lengths.

**Table 226: Blank sections**

Post-evaporator blank options		Pre-evaporator blank options
Small blank	Large blank	
Empty	Empty	Empty
Humidifier	Humidifier	Air blender
Sound attenuator	Sound attenuator	-
Final filter	Final filter	-
-	Sound attenuator and final filter	-
-	Sound attenuator and humidifier	-

## Example to determine unit length

G Z B 1 C - 1 B 5 G A - 1 A 6 0 A - E 2 0 2 B - E 2 A D G - 2 C 0 E 0 - D M A A 3 - 1 0 0 1 A - 0 0 0 C G - 0 0 0 1

③ ⑤                      ①① ①②                      ②⑦ ③⑩                      ④①

The following options are critical when determining unit length for any selected unit:

Digit 3 – Capacity: 30 ton

Digit 5 – Heat source: staged gas stainless steel

Digit 11 – Discharge location: bottom discharge

Digit 12 – Supply configuration (small or large post evaporator blank sections): none

Digit 27 – Draw-through filter options: angled filter rack, 2 in. MERV 8 filters

Digit 30 – Energy recovery options: none

Digit 41 – Pre-evap options (pre-evap blank section): none

Using the model number given as an example above, determine the unit length from [Table 205](#) through [Table 226](#)

. Unit length = [tonnage of the unit (30 ton) + economizer + draw-through filter (2 in.) + cooling coil + supply fan + condenser]\* + no ERW (refer to the no ERW section of the dimensions tables) + no pre-evap blank

① **Note:**

A standard unit includes length for economizer, draw-through filter, cooling coil, supply fan, and condenser. A standard unit includes a draw-through (pre-evaporator) filter with 2 in. angle filter or 2 in. + 12 in. (or 18 in.) filter. Units with a vertical 4 in. draw-through filter in place of the standard 2 in. angle or 2 in. + 12 in. (or 18 in.) filter are listed as SU with vertical filter 4 in.

Based on the unit options selected, the configuration is a standard unit with heat, discharge plenum (B, L, R, T). For this example, the length of the unit is 333.00 in.

# Roof curb dimensions

**Figure 19: 25 ton to 80 ton roof curbs: left bottom return opening and bottom supply opening with ERW**

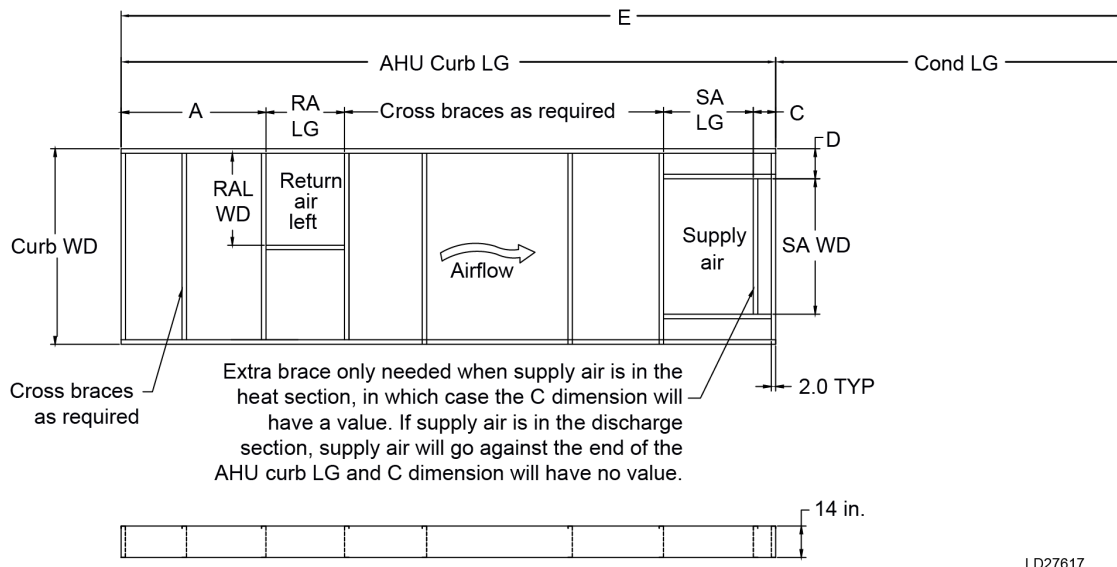

**Table 227: 25 ton to 30 ton roof curbs: left bottom return opening and bottom supply opening with ERW (in.)**

Unit configuration		AHU LG	Unit WD	AHU Curb LG	Curb WD	Cond LG	Total LG (E)	A
No heat	SU with pre-evap blank, small post-evap blank, DP (B, L, R, T)	See SU with heat, small post-evap blank, DP (B, L, R, T)						
	SU with pre-evap blank, large post-evap blank, DP (B, L, R, T)	See SU with heat, large post-evap blank, DP (B, L, R, T)						
	SU with small post-evap blank, DP (B, L, R, T)	330.90	96.05	326.4	91.55	72	398.40	84.38
	SU with large post-evap blank, DP (B, L, R, T)	372.90	96.05	368.4	91.55	72	440.40	84.38
Heat	SU with discharge through heat section (B, L)	302.90	96.05	298.40	91.55	72	370.40	84.38
	SU with heat, DP (B, L, R, T)	337.50	96.05	333.00	91.55	72	405.00	84.38
	SU with pre-evap blank, with discharge through heat section (B, L)	359.00	96.05	354.50	91.55	72	426.50	84.38
	SU with pre-evap blank, heat, DP (B, L, R, T)	390.50	96.05	386.00	91.55	72	458.00	84.38
	SU with pre-evap blank, heat, small post-evap blank, DP (B, L, R, T)	435.50	96.05	431.00	91.55	72	503.00	84.38
	SU with pre-evap blank, heat, large post-evap blank, DP (B, L, R, T)	477.50	96.05	473.00	91.55	72	545.00	84.38
	SU with heat, small post-evap blank, DP (B, L, R, T)	383.90	96.05	379.40	91.55	72	451.40	84.38
	SU with heat, large post-evap blank, DP (B, L, R, T)	425.90	96.05	421.40	91.55	72	493.40	84.38

Unit configuration		RAL WD	RA LG	C	D	SA LG	SA WD
No heat	SU with pre-evap blank, small post-evap blank, DP (B, L, R, T)	See SU with heat, small post-evap blank, DP (B, L, R, T)					
	SU with pre-evap blank, large post-evap blank, DP (B, L, R, T)	See SU with heat, large post-evap blank, DP (B, L, R, T)					
	SU with small post-evap blank, DP (B, L, R, T)	31.94	51.36	-	7.27	30.13	77.00
	SU with large post-evap blank, DP (B, L, R, T)	31.94	51.36	-	7.27	30.13	77.00

Unit configuration		RAL WD	RA LG	C	D	SA LG	SA WD
Heat	SU with discharge through heat section (B, L)	31.94	51.36	4.40	17.90	40.00	50.00
	SU with heat, DP (B, L, R, T)	31.94	51.36	-	7.27	30.13	77.00
	SU with pre-evap blank, with discharge through heat section (B, L)	31.94	51.36	4.40	17.90	40.00	50.00
	SU with pre-evap blank, heat, DP (B, L, R, T)	31.94	51.36	-	7.27	30.13	77.00
	SU with pre-evap blank, heat, small post-evap blank, DP (B, L, R, T)	31.94	51.36	-	7.27	30.13	77.00
	SU with pre-evap blank, heat, large post-evap blank, DP (B, L, R, T)	31.94	51.36	-	7.27	30.13	77.00
	SU with heat, small post-evap blank, DP (B, L, R, T)	31.94	51.36	-	7.27	30.13	77.00
	SU with heat, large post-evap blank, DP (B, L, R, T)	31.94	51.36	-	7.27	30.13	77.00

**Table 228: 40 ton to 50 ton left bottom return opening and bottom supply opening with ERW (in.)**

Unit configuration		AHU LG	Unit WD	AHU curb LG	Curb WD	Cond LG	Total LG (E)	A
No heat	SU with pre-evap blank, small post-evap blank, DP (B, L, R, T)	See SU with heat, small post-evap blank, DP (B, L, R, T)						
	SU with pre-evap blank, large post-evap blank, DP (B, L, R, T)	See SU with heat, large post-evap blank, DP (B, L, R, T)						
	SU with small post-evap blank, DP (B, L, R, T)	346.40	96.05	341.90	91.55	87.30	429.20	91.32
	SU with large post-evap blank, DP (B, L, R, T)	388.40	96.05	383.90	91.55	87.30	471.20	91.32
Heat	SU with discharge through heat section (B, L)	318.40	96.05	313.90	91.55	87.30	401.20	91.32
	SU with heat, DP (B, L, R, T)	353.00	96.05	348.50	91.55	87.30	435.80	91.32
	SU with pre-evap blank, with discharge through heat section (B, L)	376.50	96.05	372.00	91.55	87.30	459.30	91.32
	SU with pre-evap blank, heat, DP (B, L, R, T)	406.00	96.05	401.50	91.55	87.30	488.80	91.32
	SU with pre-evap blank, heat, small post-evap blank, DP (B, L, R, T)	451.00	96.05	446.50	91.55	87.30	533.80	91.32
	SU with pre-evap blank, heat, large post-evap blank, DP (B, L, R, T)	493.00	96.05	488.50	91.55	87.30	575.80	91.32
	SU with heat, small post-evap blank, DP (B, L, R, T)	399.40	96.05	394.90	91.55	87.30	482.20	91.32
	SU with heat, large post-evap blank, DP (B, L, R, T)	441.40	96.05	436.90	91.55	87.30	524.20	91.32

Unit configuration		RAL WD	RA LG	C	D	SA LG	SA WD
No heat	SU with pre-evap blank, small post-evap blank, DP (B, L, R, T)	See SU with heat, small post-evap blank, DP (B, L, R, T)					
	SU with pre-evap blank, large post-evap blank, DP (B, L, R, T)	See SU with heat, large post-evap blank, DP (B, L, R, T)					
	SU with small post-evap blank, DP (B, L, R, T)	45.00	52.86	-	7.27	30.13	77.00
	SU with large post-evap blank, DP (B, L, R, T)	45.00	52.86	-	7.27	30.13	77.00
Heat	SU with discharge through heat section (B, L)	45.00	52.86	4.40	17.90	40.00	50.00
	SU with heat, DP (B, L, R, T)	45.00	52.86	-	7.27	30.13	77.00
	SU with pre-evap blank, with discharge through heat section (B, L)	45.00	52.86	4.40	17.90	40.00	50.00
	SU with pre-evap blank, heat, DP (B, L, R, T)	45.00	52.86	-	7.27	30.13	77.00
	SU with pre-evap blank, heat, small post-evap blank, DP (B, L, R, T)	45.00	52.86	-	7.27	30.13	77.00
	SU with pre-evap blank, heat, large post-evap blank, DP (B, L, R, T)	45.00	52.86	-	7.27	30.13	77.00
	SU with heat, small post-evap blank, DP (B, L, R, T)	45.00	52.86	-	7.27	30.13	77.00
	SU with heat, large post-evap blank, DP (B, L, R, T)	45.00	52.86	-	7.27	30.13	77.00

**Table 229: 60 ton left bottom return opening with bottom supply opening with ERW (in.)**

Unit configuration		AHU LG	Unit WD	AHU curb LG	Curb WD	Cond LG	Total LG (E)	A
No heat + 55 in. SU	SU with pre-evap blank, small post-evap blank, DP (B, L, R, T) with ext eco	421.4	113.0	416.8	108.49	97.2	514.0	109.2
	SU with pre-evap blank, large post-evap blank, DP (B, L, R, T) with ext eco	463.4	113.0	458.8	108.49	97.2	556.0	109.2
	SU with small post-evap blank, DP (B, L, R, T) with ext eco	368.4	113.0	363.8	108.49	97.2	461.0	109.2
	SU with large post-evap blank, DP (B, L, R, T) with ext eco	410.4	113.0	405.8	108.49	97.2	503.0	109.2
No heat + 74 in. SU	SU with pre-evap blank, small post-evap blank, DP (B, L, R, T) with ext eco	440.4	113.0	435.8	108.49	97.2	533.0	109.2
	SU with pre-evap blank, large post-evap blank, DP (B, L, R, T) with ext eco	482.4	113.0	477.8	108.49	97.2	575.0	109.2
	SU with small post-evap blank, DP (B, L, R, T) with ext eco	387.4	113.0	382.8	108.49	97.2	480.0	109.2
	SU with large post-evap blank, DP (B, L, R, T) with ext eco	429.4	113.0	424.8	108.49	97.2	522.0	109.2
Heat	SU with discharge through heat section (B, L) with ext eco	359.4	113.0	354.8	108.49	97.2	452.0	109.2
	SU with heat, DP (B, L, R, T) with ext eco	395.4	113.0	390.8	108.49	97.2	488.0	109.2
	SU with pre-evap blank, discharge through heat section (B, L) with ext eco	412.4	113.0	407.8	108.49	97.2	505.0	109.2
	SU with pre-evap blank, heat, DP (B, L, R, T) with ext eco	448.4	113.0	443.8	108.49	97.2	541.0	109.2
	SU with pre-evap blank, heat, small post-evap blank, DP (B, L, R, T) with ext eco	493.4	113.0	488.8	108.49	97.2	586.0	109.2
	SU with pre-evap blank, heat, large post-evap blank, DP (B, L, R, T) with ext eco	535.4	113.0	530.8	108.49	97.2	628.0	109.2
	SU with heat, small post-evap blank, DP (B, L, R, T) with ext eco	440.4	113.0	435.8	108.49	97.2	533.0	109.2
	SU with heat, large post-evap blank, DP (B, L, R, T) with ext eco	482.4	113.0	477.8	108.49	97.2	575.0	109.2

**Table 230: 60 ton left bottom return opening with bottom supply opening with ERW (in.)**

Unit configuration		B	RA WD	RA LG	C	D	SA LG	SA WD
No heat + 55 in. SU	SU with pre-evap blank, small post-evap blank, DP (B, L, R, T) with ext eco	48.6	54.4	53.9	-	17.2	30.0	74.0
	SU with pre-evap blank, large post-evap blank, DP (B, L, R, T) with ext eco	48.6	54.4	53.9	-	17.2	30.0	74.0
	SU with small post-evap blank, DP (B, L, R, T) with ext eco	48.6	54.4	53.9	-	17.2	30.0	74.0
	SU with large post-evap blank, DP (B, L, R, T) with ext eco	48.6	54.4	53.9	-	17.2	30.0	74.0
No heat + 74 in. SU	SU with pre-evap blank, small post-evap blank, DP (B, L, R, T) with ext eco	48.6	54.4	53.9	-	17.2	30.0	74.0
	SU with pre-evap blank, large post-evap blank, DP (B, L, R, T) with ext eco	48.6	54.4	53.9	-	17.2	30.0	74.0
	SU with small post-evap blank, DP (B, L, R, T) with ext eco	48.6	54.4	53.9	-	17.2	30.0	74.0
	SU with large post-evap blank, DP (B, L, R, T) with ext eco	48.6	54.4	53.9	-	17.2	30.0	74.0
Heat	SU with discharge through heat section (B, L) with ext eco	48.6	54.4	53.9	-	17.2	30.0	74.0
	SU with heat, DP (B, L, R, T) with ext eco	48.6	54.4	53.9	-	17.2	30.0	74.0
	SU with pre-evap blank, discharge through heat section (B, L) with ext eco	48.6	54.4	53.9	-	17.2	30.0	74.0
	SU with pre-evap blank, heat, DP (B, L, R, T) with ext eco	48.6	54.4	53.9	-	17.2	30.0	74.0
	SU with pre-evap blank, heat, small post-evap blank, DP (B, L, R, T) with ext eco	48.6	54.4	53.9	-	17.2	30.0	74.0
	SU with pre-evap blank, heat, large post-evap blank, DP (B, L, R, T) with ext eco	48.6	54.4	53.9	-	17.2	30.0	74.0
	SU with heat, small post-evap blank, DP (B, L, R, T) with ext eco	48.6	54.4	53.9	-	17.2	30.0	74.0
	SU with heat, large post-evap blank, DP (B, L, R, T) with ext eco	48.6	54.4	53.9	-	17.2	30.0	74.0

**Table 231: 70 ton to 80 ton left bottom return opening with bottom supply opening with ERW (in.)**

Unit configuration		AHU LG	Unit WD	AHU Curb LG	Curb WD	Cond LG	Total LG (E)	A
No heat + 55 in. SU	SU with pre-evap blank, small post-evap blank, DP (B, L, R, T) with ext eco	478.9	113.0	474.3	108.49	125.2	599.5	109.2
	SU with pre-evap blank, large post-evap blank, DP (B, L, R, T) with ext eco	520.9	113.0	516.3	108.49	125.2	641.5	109.2
	SU with small post-evap blank, DP (B, L, R, T) with ext eco	425.9	113.0	421.3	108.49	125.2	546.5	109.2
	SU with large post-evap blank, DP (B, L, R, T) with ext eco	467.9	113.0	463.3	108.49	125.2	588.5	109.2
No heat + 74 in. SU	SU with pre-evap blank, small post-evap blank, DP (B, L, R, T) with ext eco	497.9	113.0	493.3	108.49	125.2	618.5	109.2
	SU with pre-evap blank, large post-evap blank, DP (B, L, R, T) with ext eco	539.9	113.0	535.3	108.49	125.2	660.5	109.2
	SU with small post-evap blank, DP (B, L, R, T) with ext eco	444.9	113.0	440.3	108.49	125.2	565.5	109.2
	SU with large post-evap blank, DP (B, L, R, T) with ext eco	486.9	113.0	482.3	108.49	125.2	607.5	109.2

**Table 231: 70 ton to 80 ton left bottom return opening with bottom supply opening with ERW (in.)**

Unit configuration		AHU LG	Unit WD	AHU Curb LG	Curb WD	Cond LG	Total LG (E)	A
Heat	SU with discharge through heat section (B, L) with ext eco	406.9	113.0	402.3	108.49	125.2	527.5	109.2
	SU with Heat, DP (B, L, R, T) with ext eco	452.9	113.0	448.3	108.49	125.2	573.5	109.2
	SU with pre-evap blank, discharge through heat section (B, L) with ext eco	459.9	113.0	455.3	108.49	125.2	580.5	109.2
	SU with pre-evap blank, heat, DP (B, L, R, T) with ext eco	505.9	113.0	501.3	108.49	125.2	626.5	109.2
	SU with pre-evap blank, heat, small post-evap blank, DP (B, L, R, T) with ext eco	550.9	113.0	546.3	108.49	125.2	671.5	109.2
	SU with pre-evap blank, heat, large post-evap blank, DP (B, L, R, T) with ext eco	592.9	113.0	588.3	108.49	125.2	713.5	109.2
	SU with heat, small post-evap blank, DP (B, L, R, T) with ext eco	497.9	113.0	493.3	108.49	125.2	618.5	109.2
	SU with heat, large post-evap blank, DP (B, L, R, T) with ext eco	539.9	113.0	535.3	108.49	125.2	660.5	109.2

**Table 232: 70 ton to 80 ton left bottom return opening with bottom supply opening with ERW (in.)**

Unit Configuration		B	RA WD	RA LG	C	D	SA LG	SA WD
No heat + 55 in. SU	SU with pre-evap blank, small post-evap blank, DP (B, L, R, T) with ext eco	62.6	54.4	72.9	-	17.2	40.0	74.0
	SU with pre-evap blank, large post-evap blank, DP (B, L, R, T) with ext eco	62.6	54.4	72.9	-	17.2	40.0	74.0
	SU with small post-evap blank, DP (B, L, R, T) with ext eco	62.6	54.4	72.9	-	17.2	40.0	74.0
	SU with large post-evap blank, DP (B, L, R, T) with ext eco	62.6	54.4	72.9	-	17.2	40.0	74.0
No heat + 74 in. SU	SU with pre-evap blank, small post-evap blank, DP (B, L, R, T) with ext eco	62.6	54.4	72.9	-	17.2	40.0	74.0
	SU with pre-evap blank, large post-evap blank, DP (B, L, R, T) with ext eco	62.6	54.4	72.9	-	17.2	40.0	74.0
	SU with small post-evap blank, DP (B, L, R, T) with ext eco	62.6	54.4	72.9	-	17.2	40.0	74.0
	SU with large post-evap blank, DP (B, L, R, T) with ext eco	62.6	54.4	72.9	-	17.2	40.0	74.0
Heat	SU with discharge through heat section (B, L) with ext eco	62.6	54.4	72.9	-	17.2	40.0	74.0
	SU with heat, DP (B, L, R, T) with ext eco	62.6	54.4	72.9	-	17.2	40.0	74.0
	SU with pre-evap blank, discharge through heat section (B, L) with ext eco	62.6	54.4	72.9	-	17.2	40.0	74.0
	SU with pre-evap blank, heat, DP (B, L, R, T) with ext eco	62.6	54.4	72.9	-	17.2	40.0	74.0
	SU with pre-evap blank, heat, small post-evap blank, DP (B, L, R, T) with ext eco	62.6	54.4	72.9	-	17.2	40.0	74.0
	SU with pre-evap blank, heat, large post-evap blank, DP (B, L, R, T) with ext eco	62.6	54.4	72.9	-	17.2	40.0	74.0
	SU with heat, small post-evap blank, DP (B, L, R, T) with ext eco	62.6	54.4	72.9	-	17.2	40.0	74.0
	SU with heat, large post-evap blank, DP (B, L, R, T) with ext eco	62.6	54.4	72.9	-	17.2	40.0	74.0

**Note:**

1. AHU = Air Handling Unit, LG = Length, WD = Width, Cond = Condenser, RA = Return Air, RAL = RA Left, SA = Supply Air, SU = Standard Unit

2. DP = Discharge Plenum, B = Bottom, L = Left, R = Right, T = Top

**Figure 20: 25 ton to 50 ton roof curbs: left bottom return opening and bottom supply opening without ERW**

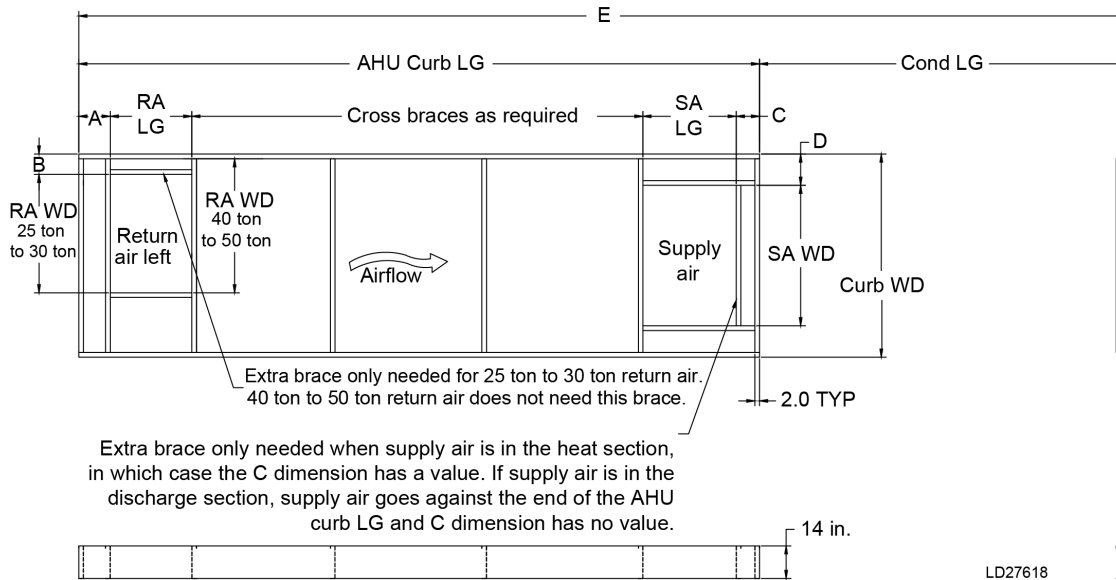

LD27618

**Table 233: 25 ton to 30 ton roof curbs: left bottom return opening and bottom supply opening without ERW (in.)**

Unit configuration		AHU LG	Unit WD	AHU Curb LG	Curb WD	Cond LG	Total LG (E)	A
No heat	SU with vertical filter 4 in., DP (B, L, R, T)	192.40	96.05	187.90	91.55	72.00	259.90	11.41
	SU with DP (B, L, R, T)	209.40	96.05	204.90	91.55	72.00	276.90	11.41
	SU with pre-evap blank, small post-evap blank, DP (B, L, R, T)	See SU with heat, small post-evap blank, DP (B, L, R, T)						
	SU with pre-evap blank, large post-evap blank, DP (B, L, R, T)	See SU with heat, large post-evap blank, DP (B, L, R, T)						
	SU with small post-evap blank, DP (B, L, R, T)	254.40	96.05	249.90	91.55	72.00	321.90	11.41
	SU with large post-evap blank, DP (B, L, R, T)	302.90	96.05	298.40	91.55	72.00	370.40	11.41
Heat	SU with vertical filter 4 in., with discharge through heat section (B, L)	209.40	96.05	204.90	91.55	72.00	276.90	11.41
	SU with discharge through heat section (B, L)	226.40	96.05	221.90	91.55	72.00	293.90	11.41
	SU with heat, DP (B, L, R, T)	261.00	96.05	256.50	91.55	72.00	328.50	11.41
	SU with pre-evap blank, with discharge through heat section (B, L)	279.40	96.05	274.90	91.55	72.00	346.90	11.41
	SU with pre-evap blank, heat, DP (B, L, R, T)	314.00	96.05	309.50	91.55	72.00	381.50	11.41
	SU with pre-evap blank, heat, small post-evap blank, DP (B, L, R, T)	359.00	96.05	354.50	91.55	72.00	426.50	11.41
	SU with pre-evap blank, heat, large post-evap blank, DP (B, L, R, T)	401.00	96.05	396.50	91.55	72.00	468.50	11.41
	SU with heat, small post-evap blank, DP (B, L, R, T)	307.40	96.05	302.90	91.55	72.00	374.90	11.41
	SU with heat, large post-evap blank, DP (B, L, R, T)	349.40	96.05	344.90	91.55	72.00	416.90	11.41

**Table 234: 25 ton to 30 ton left bottom return opening with bottom supply opening without ERW (in.)**

Unit configuration		B	RA WD	RA LG	C	D	SA LG	SA WD
No heat	SU with vertical filter 4 in., DP (B, L, R, T)	9.35	51.00	33.73	-	7.27	30.13	77.00
	SU with DP (B, L, R, T)	9.35	51.00	33.73	-	7.27	30.13	77.00
	SU with pre-evap blank, small post-evap blank, DP (B, L, R, T)	See SU with heat, small post-evap blank, DP (B, L, R, T)						
	SU with pre-evap blank, large post-evap blank, DP (B, L, R, T)	See SU with heat, small post-evap blank, DP (B, L, R, T)						
	SU with small post-evap blank, DP (B, L, R, T)	9.35	51.00	33.73	-	7.27	30.13	77.00
	SU with large post-evap blank, DP (B, L, R, T)	9.35	51.00	33.73	-	7.27	30.13	77.00
Heat	SU with vertical filter 4 in., with discharge through heat section (B, L)	9.35	51.00	33.73	4.40	17.90	40.00	50.00
	SU with discharge through heat section (B, L)	9.35	51.00	33.73	4.40	17.90	40.00	50.00
	SU with heat, DP (B, L, R, T)	9.35	51.00	33.73	-	7.27	30.13	77.00
	SU with pre-evap blank, with discharge through heat section (B, L)	9.35	51.00	33.73	4.40	17.90	40.00	50.00
	SU with pre-evap blank, heat, DP (B, L, R, T)	9.35	51.00	33.73	-	7.27	30.13	77.00
	SU with pre-evap blank, heat, small post-evap blank, DP (B, L, R, T)	9.35	51.00	33.73	-	7.27	30.13	77.00
	SU with pre-evap blank, heat, large post-evap blank, DP (B, L, R, T)	9.35	51.00	33.73	-	7.27	30.13	77.00
	SU with heat, small post-evap blank, DP (B, L, R, T)	9.35	51.00	33.73	-	7.27	30.13	77.00
	SU with heat, large post-evap blank, DP (B, L, R, T)	9.35	51.00	33.73	-	7.27	30.13	77.00

**Table 235: 40 ton to 50 ton left bottom return opening with bottom supply opening without ERW (in.)**

Unit configuration		AHU LG	Unit WD	AHU curb LG	Curb WD	Cond LG	Total LG (E)	A
No heat	SU with vertical filter 4 in., DP (B, L, R, T)	209.90	96.05	205.40	91.55	87.30	292.70	11.41
	SU with DP (B, L, R, T)	226.90	96.05	222.40	91.55	87.30	309.70	11.41
	SU with pre-evap blank, small post-evap blank, DP (B, L, R, T)	See SU with heat, small post-evap blank, DP (B, L, R, T)						
	SU with pre-evap blank, large post-evap blank, DP (B, L, R, T)	See SU with heat, large post-evap blank, DP (B, L, R, T)						
	SU with small post-evap blank, DP (B, L, R, T)	271.90	96.05	267.40	91.55	87.30	354.70	11.41
	SU with large post-evap blank, DP (B, L, R, T)	318.40	96.05	313.90	91.55	87.30	401.20	11.41
Heat	SU with vertical filter 4 in., with discharge through heat section (B, L)	226.90	96.05	222.40	91.55	87.30	309.70	11.41
	SU with discharge through heat section (B, L)	243.90	96.05	239.40	91.55	87.30	326.70	11.41
	SU with heat, DP (B, L, R, T)	278.50	96.05	274.00	91.55	87.30	361.30	11.41
	SU with pre-evap blank, with discharge through heat section (B, L)	296.90	96.05	292.40	91.55	87.30	379.70	11.41
	SU with pre-evap blank, heat, DP (B, L, R, T)	331.50	96.05	327.00	91.55	87.30	414.30	11.41
	SU with pre-evap blank, heat, small post-evap blank, DP (B, L, R, T)	376.50	96.05	372.00	91.55	87.30	459.30	11.41
	SU with pre-evap blank, heat, large post-evap blank, DP (B, L, R, T)	418.50	96.05	414.00	91.55	87.30	501.30	11.41
	SU with heat, small post-evap blank, DP (B, L, R, T)	324.90	96.05	320.40	91.55	87.30	407.70	11.41
	SU with heat, large post-evap blank, DP (B, L, R, T)	366.90	96.05	362.40	91.55	87.30	449.70	11.41

**Table 236: 40 ton to 50 ton left bottom return opening with bottom supply opening without ERW (in.)**

Unit configuration		B	RA WD	RA LG	C	D	SA LG	SA WD
No heat	SU with vertical filter 4 in., DP (B, L, R, T)	-	72.99	37.63	-	7.27	30.13	77.00
	SU with DP (B, L, R, T)	-	72.99	37.63	-	7.27	30.13	77.00
	SU with pre-evap blank, small post-evap blank, DP (B, L, R, T)	See SU with heat, small post-evap blank, DP (B, L, R, T)						
	SU with pre-evap blank, large post-evap blank, DP (B, L, R, T)	See SU with heat, large post-evap blank, DP (B, L, R, T)						
	SU with small post-evap blank, DP (B, L, R, T)	-	72.99	37.63	-	7.27	30.13	77.00
	SU with large post-evap blank, DP (B, L, R, T)	-	72.99	37.63	-	7.27	30.13	77.00
Heat	SU with vertical filter 4 in., with discharge through heat section (B, L)	-	72.99	37.63	4.40	17.90	40.00	50.00
	SU with discharge through heat section (B, L)	-	72.99	37.63	4.40	17.90	40.00	50.00
	SU with heat, DP (B, L, R, T)	-	72.99	37.63	-	7.27	30.13	77.00
	SU with pre-evap blank, with discharge through heat section (B, L)	-	72.99	37.63	4.40	17.90	40.00	50.00
	SU with pre-evap blank, heat, DP (B, L, R, T)	-	72.99	37.63	-	7.27	30.13	77.00
	SU with pre-evap blank, heat, small post-evap blank, DP (B, L, R, T)	-	72.99	37.63	-	7.27	30.13	77.00
	SU with pre-evap blank, heat, large post-evap blank, DP (B, L, R, T)	-	72.99	37.63	-	7.27	30.13	77.00
	SU with heat, small post-evap blank, DP (B, L, R, T)	-	72.99	37.63	-	7.27	30.13	77.00
	SU with heat, large post-evap blank, DP (B, L, R, T)	-	72.99	37.63	-	7.27	30.13	77.00

**Note:**

- AHU = Air Handling Unit, LG = Length, WD = Width, Cond = Condenser, RA = Return Air, RAR = RA Right, RAL = RA Left, SA = Supply Air
- SU = Standard Unit, DP = Discharge Plenum, B = Bottom, L = Left, R = Right, T = Top

**Figure 21: 25 ton to 50 ton roof curbs: right bottom return opening and bottom supply opening without ERW**

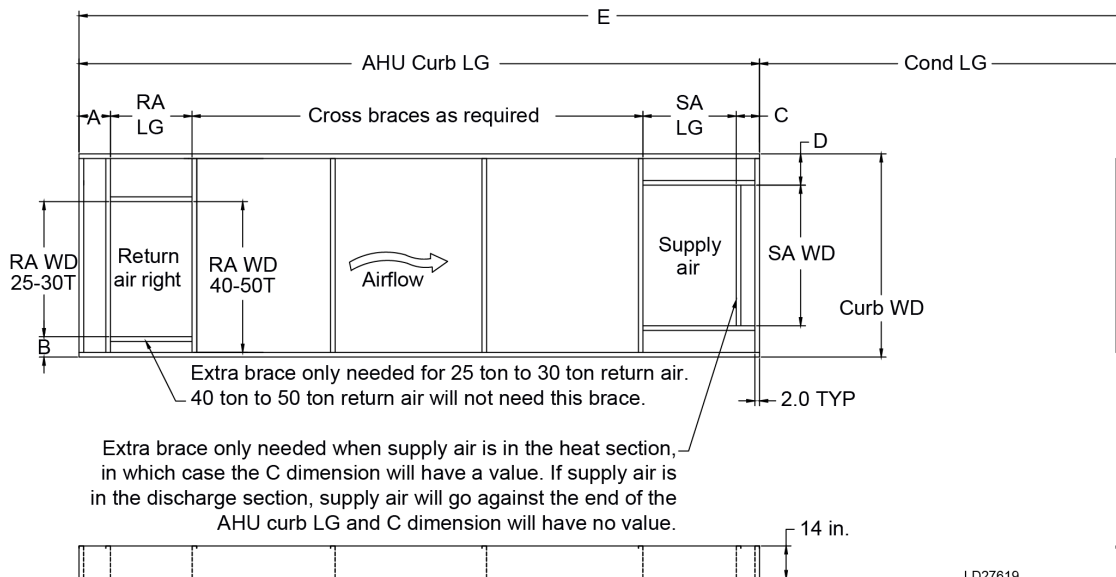

**Table 237: 25 ton to 30 ton roof curbs: right bottom return opening and bottom supply opening without ERW (in.)**

Unit configuration		AHU LG	Unit WD	AHU curb LG	Curb WD	Cond LG	Total LG (E)	A
No heat	SU with vertical filter 4 in., DP (B, L, R, T)	192.40	96.05	187.90	91.55	72.00	259.90	11.41
	SU with DP (B, L, R, T)	209.40	96.05	204.90	91.55	72.00	276.90	11.41
	SU with pre-evap blank, small post-evap blank, DP (B, L, R, T)	See SU with heat, small post-evap blank, DP (B, L, R, T)						
	SU with pre-evap blank, large post-evap blank, DP (B, L, R, T)	See SU with heat, large post-evap blank, DP (B, L, R, T)						
	SU with small post-evap blank, DP (B, L, R, T)	254.40	96.05	249.90	91.55	72.00	321.90	11.41
	SU with large post-evap blank, DP (B, L, R, T)	302.90	96.05	298.40	91.55	72.00	370.40	11.41
Heat	SU with vertical filter 4 in., with discharge through heat section (B, L)	209.40	96.05	204.90	91.55	72.00	276.90	11.41
	SU with discharge through heat section (B, L)	226.40	96.05	221.90	91.55	72.00	293.90	11.41
	SU with Heat, DP (B, L, R, T)	261.00	96.05	256.50	91.55	72.00	328.50	11.41
	SU with pre-evap blank, with discharge through heat section (B, L)	279.40	96.05	274.90	91.55	72.00	346.90	11.41
	SU with pre-evap blank, heat, DP (B, L, R, T)	314.00	96.05	309.50	91.55	72.00	381.50	11.41
	SU with pre-evap blank, heat, small post-evap blank, DP (B, L, R, T)	359.00	96.05	354.50	91.55	72.00	426.50	11.41
	SU with pre-evap blank, heat, large post-evap blank, DP (B, L, R, T)	401.00	96.05	396.50	91.55	72.00	468.50	11.41
	SU with heat, small post-evap blank, DP (B, L, R, T)	307.40	96.05	302.90	91.55	72.00	374.90	11.41
	SU with heat, large post-evap blank, DP (B, L, R, T)	349.40	96.05	344.90	91.55	72.00	416.90	11.41

Unit configuration		B	RA WD	RA LG	C	D	SA LG	SA WD
No heat	SU with vertical filter 4 in., DP (B, L, R, T)	9.35	51.00	33.73	-	7.27	30.13	77.00
	SU with DP (B, L, R, T)	9.35	51.00	33.73	-	7.27	30.13	77.00
	SU with pre-evap blank, small post-evap blank, DP (B, L, R, T)	See SU with heat, small post-evap blank, DP (B, L, R, T)						
	SU with pre-evap blank, large post-evap blank, DP (B, L, R, T)	See SU with heat, small post-evap blank, DP (B, L, R, T)						
	SU with small post-evap blank, DP (B, L, R, T)	9.35	51.00	33.73	-	7.27	30.13	77.00
	SU with large post-evap blank, DP (B, L, R, T)	9.35	51.00	33.73	-	7.27	30.13	77.00
Heat	SU with vertical filter 4 in., with discharge through heat section (B, L)	9.35	51.00	33.73	4.40	17.90	40.00	50.00
	SU with discharge through heat section (B, L)	9.35	51.00	33.73	4.40	17.90	40.00	50.00
	SU with heat, DP (B, L, R, T)	9.35	51.00	33.73	-	7.27	30.13	77.00
	SU with pre-evap blank, with discharge through heat section (B, L)	9.35	51.00	33.73	4.40	17.90	40.00	50.00
	SU with pre-evap blank, heat, DP (B, L, R, T)	9.35	51.00	33.73	-	7.27	30.13	77.00
	SU with pre-evap blank, heat, small post-evap blank, DP (B, L, R, T)	9.35	51.00	33.73	-	7.27	30.13	77.00
	SU with pre-evap blank, heat, large post-evap blank, DP (B, L, R, T)	9.35	51.00	33.73	-	7.27	30.13	77.00
	SU with heat, small post-evap blank, DP (B, L, R, T)	9.35	51.00	33.73	-	7.27	30.13	77.00
	SU with heat, large post-evap blank, DP (B, L, R, T)	9.35	51.00	33.73	-	7.27	30.13	77.00

**Table 238: 40 ton to 50 ton right bottom return opening with bottom supply opening without ERW (in.)**

Unit configuration		AHU LG	Unit WD	AHU curb LG	Curb WD	Cond LG	Total LG (E)	A
No heat	SU with vertical filter 4 in., DP (B, L, R, T)	209.90	96.05	205.40	91.55	87.30	292.70	11.41
	SU with DP (B, L, R, T)	226.90	96.05	222.40	91.55	87.30	309.70	11.41
	SU with pre-evap blank, small post-evap blank, DP (B, L, R, T)	See SU with heat, small post-evap blank, DP (B, L, R, T)						
	SU with pre-evap blank, large post-evap blank, DP (B, L, R, T)	See SU with heat, large post-evap blank, DP (B, L, R, T)						
	SU with small post-evap blank, DP (B, L, R, T)	271.90	96.05	267.40	91.55	87.30	354.70	11.41
	SU with large post-evap blank, DP (B, L, R, T)	318.40	96.05	313.90	91.55	87.30	401.20	11.41
Heat	SU with vertical filter 4 in., with discharge through heat section (B, L)	226.90	96.05	222.40	91.55	87.30	309.70	11.41
	SU with discharge through heat section (B, L)	243.90	96.05	239.40	91.55	87.30	326.70	11.41
	SU with heat, DP (B, L, R, T)	278.50	96.05	274.00	91.55	87.30	361.30	11.41
	SU with pre-evap blank, with discharge through heat section (B, L)	296.90	96.05	292.40	91.55	87.30	379.70	11.41
	SU with pre-evap blank, heat, DP (B, L, R, T)	331.50	96.05	327.00	91.55	87.30	414.30	11.41
	SU with pre-evap blank, heat, small post-evap blank, DP (B, L, R, T)	376.50	96.05	372.00	91.55	87.30	459.30	11.41
	SU with pre-evap blank, heat, large post-evap blank, DP (B, L, R, T)	418.50	96.05	414.00	91.55	87.30	501.30	11.41
	SU with heat, small post-evap blank, DP (B, L, R, T)	324.90	96.05	320.40	91.55	87.30	407.70	11.41
	SU with heat, large post-evap blank, DP (B, L, R, T)	366.90	96.05	362.40	91.55	87.30	449.70	11.41

Unit configuration		B	RA WD	RA LG	C	D	SA LG	SA WD
No heat	SU with vertical filter 4 in., DP (B, L, R, T)	-	72.99	37.63	-	7.27	30.13	77.00
	SU with DP (B, L, R, T)	-	72.99	37.63	-	7.27	30.13	77.00
	SU with pre-evap blank, small post-evap blank, DP (B, L, R, T)	See SU with heat, small post-evap blank, DP (B, L, R, T)						
	SU with pre-evap blank, large post-evap blank, DP (B, L, R, T)	See SU with heat, large post-evap blank, DP (B, L, R, T)						
	SU with small post-evap blank, DP (B, L, R, T)	-	72.99	37.63	-	7.27	30.13	77.00
	SU with large post-evap blank, DP (B, L, R, T)	-	72.99	37.63	-	7.27	30.13	77.00
Heat	SU with vertical filter 4 in., with discharge through heat section (B, L)	-	72.99	37.63	4.40	17.90	40.00	50.00
	SU with discharge through heat section (B, L)	-	72.99	37.63	4.40	17.90	40.00	50.00
	SU with heat, DP (B, L, R, T)	-	72.99	37.63	-	7.27	30.13	77.00
	SU with pre-evap blank, with discharge through heat section (B, L)	-	72.99	37.63	4.40	17.90	40.00	50.00
	SU with pre-evap blank, heat, DP (B, L, R, T)	-	72.99	37.63	-	7.27	30.13	77.00
	SU with pre-evap blank, heat, small post-evap blank, DP (B, L, R, T)	-	72.99	37.63	-	7.27	30.13	77.00
	SU with pre-evap blank, heat, large post-evap blank, DP (B, L, R, T)	-	72.99	37.63	-	7.27	30.13	77.00
	SU with heat, small post-evap blank, DP (B, L, R, T)	-	72.99	37.63	-	7.27	30.13	77.00
SU with heat, large post-evap blank, DP (B, L, R, T)	-	72.99	37.63	-	7.27	30.13	77.00	

**Figure 22: 60 ton to 80 ton roof curbs left bottom return opening and bottom supply opening without ERW**

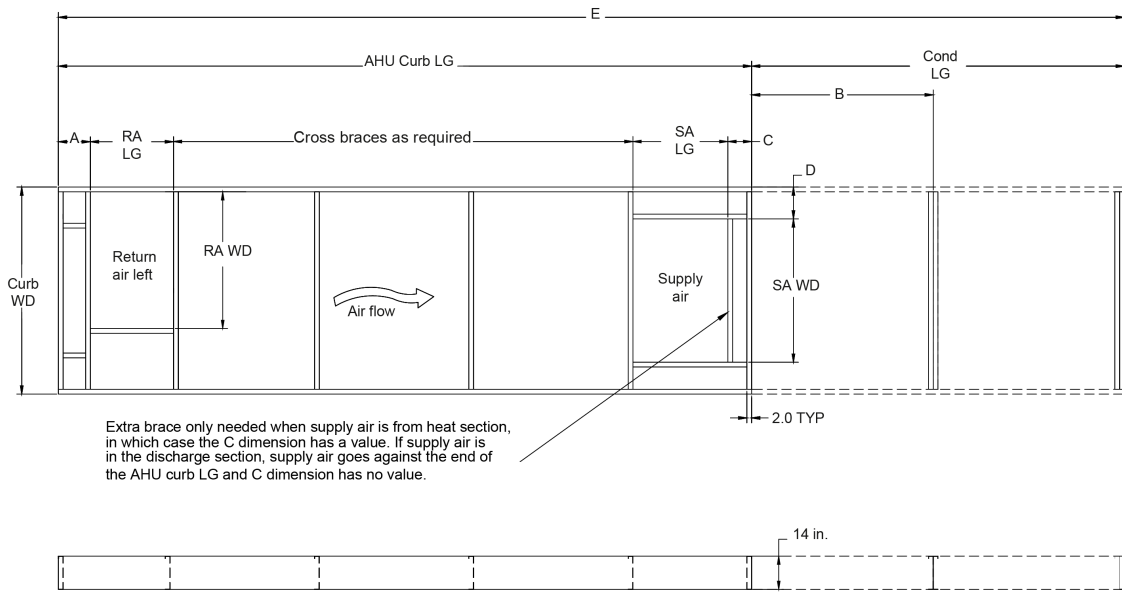

LD30033

**Table 239: 60 ton left bottom return opening with bottom supply opening without ERW (in.)**

Unit configuration		AHU LG	Unit WD	AHU Curb LG	Curb WD	Cond LG	Total LG (E)	A
No heat + 55 in. SU	SU with vertical filter 4 in., DP (B, L, R, T) with basic eco	201.4	113.0	196.8	108.49	97.2	294.0	3.8
	SU with vertical filter 4 in., DP (B, L, R, T) with standard eco	225.4	113.0	220.8	108.49	97.2	318.0	11.4
	SU with DP (B, L, R, T) with basic eco	218.4	113.0	213.8	108.49	97.2	311.0	3.8
	SU with DP (B, L, R, T) with standard eco	242.4	113.0	237.8	108.49	97.2	335.0	11.4
	SU with pre-evap blank, small post-evap blank, DP (B, L, R, T) with basic eco	316.4	113.0	311.8	108.49	97.2	409	3.8
	SU with pre-evap blank, small post-evap blank, DP (B, L, R, T) with std eco	340.4	113.0	335.8	108.49	97.2	433	11.4
	SU with pre-evap blank, large post-evap blank, DP (B, L, R, T) with basic eco	358.4	113.0	353.8	108.49	97.2	451	3.8
	SU with pre-evap blank, large post-evap blank, DP (B, L, R, T) with std eco	382.4	113.0	377.8	108.49	97.2	475	11.4
	SU with small post-evap blank, DP (B, L, R, T) with basic eco	263.4	113.0	258.8	108.49	97.2	356	3.8
	SU with small post-evap blank, DP (B, L, R, T) with std eco	287.4	113.0	282.8	108.49	97.2	380	11.4
	SU with large post-evap blank, DP (B, L, R, T) with basic eco	305.4	113.0	300.8	108.49	97.2	398	3.8
	SU with large post-evap blank, DP (B, L, R, T) with std eco	329.4	113.0	324.8	108.49	97.2	422	11.4

**Table 239: 60 ton left bottom return opening with bottom supply opening without ERW (in.)**

Unit configuration		AHU LG	Unit WD	AHU Curb LG	Curb WD	Cond LG	Total LG (E)	A
No heat + 74 in. SU	SU with pre-evap blank, small post-evap blank, DP (B, L, R, T) with basic eco	335.4	113.0	330.8	108.49	97.2	428	3.8
	SU with pre-evap blank, small post-evap blank, DP (B, L, R, T) with std eco	359.4	113.0	354.8	108.49	97.2	452	11.4
	SU with pre-evap blank, large post-evap blank, DP (B, L, R, T) with basic eco	377.4	113.0	372.8	108.49	97.2	470	3.8
	SU with pre-evap blank, large post-evap blank, DP (B, L, R, T) with std eco	401.4	113.0	396.8	108.49	97.2	494	11.4
	SU with small post-evap blank, DP (B, L, R, T) with basic eco	282.4	113.0	277.8	108.49	97.2	375.0	3.8
	SU with small post-evap blank, DP (B, L, R, T) with standard eco	306.4	113.0	301.8	108.49	97.2	399.0	11.4
	SU with large post-evap blank, DP (B, L, R, T) with basic eco	324.4	113.0	319.8	108.49	97.2	417	3.8
	SU with large post-evap blank, DP (B, L, R, T) with std eco	348.4	113.0	343.8	108.49	97.2	441	11.4

**Table 239: 60 ton left bottom return opening with bottom supply opening without ERW (in.)**

Unit configuration		AHU LG	Unit WD	AHU Curb LG	Curb WD	Cond LG	Total LG (E)	A
Heat	SU with vertical filter 4 in., with discharge through heat section (B, L) with basic eco	237.4	113.0	232.8	108.49	97.2	330.0	3.8
	SU with vertical filter 4 in., with discharge through heat section (B, L) with standard eco	261.4	113.0	256.8	108.49	97.2	354.0	11.4
	SU with discharge through heat section (B, L) with basic eco	254.4	113.0	249.8	108.49	97.2	347.0	3.8
	SU with discharge through heat section (B, L) with standard eco	278.4	113.0	273.8	108.49	97.2	371.0	11.4
	SU with heat, DP (B, L, R, T) with basic eco	290.4	113.0	285.8	108.49	97.2	383.0	3.8
	SU with heat, DP (B, L, R, T) with standard eco	314.4	113.0	309.8	108.49	97.2	407.0	11.4
	SU with pre-evap blank, discharge through heat section (B, L) with basic eco	307.4	113.0	302.8	108.49	97.2	400	3.8
	SU with pre-evap blank, discharge through heat section (B, L) with std eco	331.4	113.0	326.8	108.49	97.2	424	11.4
	SU with pre-evap blank, heat, DP (B, L, R, T) with basic eco	343.4	113.0	338.8	108.49	97.2	436	3.8
	SU with pre-evap blank, heat, DP (B, L, R, T) with std eco	367.4	113.0	362.8	108.49	97.2	460	11.4
	SU with pre-evap blank, heat, small post-evap blank, DP (B, L, R, T) with basic eco	388.4	113.0	383.8	108.49	97.2	481	3.8
	SU with pre-evap blank, heat, small post-evap blank, DP (B, L, R, T) with std eco	412.4	113.0	407.8	108.49	97.2	505	11.4
	SU with pre-evap blank, heat, large post-evap blank, DP (B, L, R, T) with basic eco	430.4	113.0	425.8	108.49	97.2	523	3.8
	SU with pre-evap blank, heat, large post-evap blank, DP (B, L, R, T) with std eco	454.4	113.0	449.8	108.49	97.2	547	11.4
	SU with heat, small post-evap blank, DP (B, L, R, T) with basic eco	335.4	113.0	330.8	108.49	97.2	428.0	3.8
	SU with heat, small post-evap blank, DP (B, L, R, T) with standard eco	359.4	113.0	354.8	108.49	97.2	452.0	11.4
	SU with heat, large post-evap blank, DP (B, L, R, T) with basic eco	377.4	113.0	372.8	108.49	97.2	470	3.8
	SU with heat, large post-evap blank, DP (B, L, R, T) with std eco	401.4	113.0	396.8	108.49	97.2	494	11.4

**Table 240: 60 ton left bottom return opening with bottom supply opening without ERW (in.)**

Unit configuration		B	RA WD	RA LG	C	D	SA LG	SA WD
No heat + 55 in. SU	SU with vertical filter 4 in., DP (B, L, R, T) with basic eco	48.6	65.0	54.3	-	17.2	30.0	74.0
	SU with vertical filter 4 in., DP (B, L, R, T) with standard eco	48.6	77.9	56.9	-	17.2	30.0	74.0
	SU with DP (B, L, R, T) with basic eco	48.6	65.0	54.3	-	17.2	30.0	74.0
	SU with DP (B, L, R, T) with standard eco	48.6	77.9	56.9	-	17.2	30.0	74.0
	SU with pre-evap blank, small post-evap blank, DP (B, L, R, T) with basic eco	48.6	65.0	54.3	-	17.2	30.0	74.0
	SU with pre-evap blank, small post-evap blank, DP (B, L, R, T) with std eco	48.6	77.9	56.9	-	17.2	30.0	74.0
	SU with pre-evap blank, large post-evap blank, DP (B, L, R, T) with basic eco	48.6	65.0	54.3	-	17.2	30.0	74.0
	SU with pre-evap blank, large post-evap blank, DP (B, L, R, T) with std eco	48.6	77.9	56.9	-	17.2	30.0	74.0
	SU with small post-evap blank, DP (B, L, R, T) with basic eco	48.6	65.0	54.3	-	17.2	30.0	74.0
	SU with small post-evap blank, DP (B, L, R, T) with std eco	48.6	77.9	56.9	-	17.2	30.0	74.0
	SU with large post-evap blank, DP (B, L, R, T) with basic eco	48.6	65.0	54.3	-	17.2	30.0	74.0
	SU with large post-evap blank, DP (B, L, R, T) with std eco	48.6	77.9	56.9	-	17.2	30.0	74.0
No heat + 74 in. SU	SU with pre-evap blank, small post-evap blank, DP (B, L, R, T) with basic eco	48.6	65.0	54.3	-	17.2	30.0	74.0
	SU with pre-evap blank, small post-evap blank, DP (B, L, R, T) with std eco	48.6	77.9	56.9	-	17.2	30.0	74.0
	SU with pre-evap blank, large post-evap blank, DP (B, L, R, T) with basic eco	48.6	65.0	54.3	-	17.2	30.0	74.0
	SU with pre-evap blank, large post-evap blank, DP (B, L, R, T) with std eco	48.6	77.9	56.9	-	17.2	30.0	74.0
	SU with small post-evap blank, DP (B, L, R, T) with basic eco	48.6	65.0	54.3	-	17.2	30.0	74.0
	SU with small post-evap blank, DP (B, L, R, T) with standard eco	48.6	77.9	56.9	-	17.2	30.0	74.0
	SU with large post-evap blank, DP (B, L, R, T) with basic eco	48.6	65.0	54.3	-	17.2	30.0	74.0
	SU with large post-evap blank, DP (B, L, R, T) with std eco	48.6	77.9	56.9	-	17.2	30.0	74.0

**Table 240: 60 ton left bottom return opening with bottom supply opening without ERW (in.)**

Unit configuration		B	RA WD	RA LG	C	D	SA LG	SA WD
Heat	SU with vertical filter 4 in., with discharge through heat section (B, L) with basic eco	48.6	65.0	54.3	4.2	24.3	40.0	60.0
	SU with vertical filter 4 in., with discharge through heat section (B, L) with standard eco	48.6	77.9	56.9	4.2	24.3	40.0	60.0
	SU with discharge through heat section (B, L) with basic eco	48.6	65.0	54.3	4.2	24.3	40.0	60.0
	SU with discharge through heat section (B, L) with standard eco	48.6	77.9	56.9	4.2	24.3	40.0	60.0
	SU with heat, DP (B, L, R, T) with basic eco	48.6	65.0	54.3	-	17.2	30.0	74.0
	SU with heat, DP (B, L, R, T) with standard eco	48.6	77.9	56.9	-	17.2	30.0	74.0
	SU with pre-evap blank, discharge through heat section (B, L) with basic eco	48.6	65.0	54.3	4.2	24.3	40.0	60.0
	SU with pre-evap blank, discharge through heat section (B, L) with std eco	48.6	77.9	56.9	4.2	24.3	40.0	60.0
	SU with pre-evap blank, heat, DP (B, L, R, T) with basic eco	48.6	65.0	54.3	4.2	24.3	40.0	60.0
	SU with pre-evap blank, heat, DP (B, L, R, T) with std eco	48.6	77.9	56.9	4.2	24.3	40.0	60.0
	SU with pre-evap blank, heat, small post-evap blank, DP (B, L, R, T) with basic eco	48.6	65.0	54.3	4.2	24.3	40.0	60.0
	SU with pre-evap blank, heat, small post-evap blank, DP (B, L, R, T) with std eco	48.6	77.9	56.9	4.2	24.3	40.0	60.0
	SU with pre-evap blank, heat, large post-evap blank, DP (B, L, R, T) with basic eco	48.6	65.0	54.3	4.2	24.3	40.0	60.0
	SU with pre-evap blank, heat, large post-evap blank, DP (B, L, R, T) with std eco	48.6	77.9	56.9	4.2	24.3	40.0	60.0
	SU with heat, small post-evap blank, DP (B, L, R, T) with basic eco	48.6	65.0	54.3	-	17.2	30.0	74.0
	SU with heat, small post-evap blank, DP (B, L, R, T) with standard eco	48.6	77.9	56.9	-	17.2	30.0	74.0
SU with heat, large post-evap blank, DP (B, L, R, T) with basic eco	48.6	65.0	54.3	-	17.2	30.0	74.0	
SU with heat, large post-evap blank, DP (B, L, R, T) with std eco	48.6	77.9	56.9	-	17.2	30.0	74.0	

**Table 241: 70 ton to 80 ton left bottom return opening with bottom supply opening without ERW (in.)**

Unit configuration		AHU LG	Unit WD	AHU Curb LG	Curb WD	Cond LG	Total LG (E)	A
No heat + 55 in. SU	SU with vertical filter 4 in., DP (B, L, R, T) with basic eco	239.9	113.0	235.3	108.49	125.2	360.5	3.8
	SU with vertical filter 4 in., DP (B, L, R, T) with standard eco	263.9	113.0	259.3	108.49	125.2	384.5	11.4
	SU with DP (B, L, R, T) with basic eco	256.9	113.0	252.3	108.49	125.2	377.5	3.8
	SU with DP (B, L, R, T) with standard eco	280.9	113.0	276.3	108.49	125.2	401.5	11.4
	SU with pre-evap blank, small post-evap blank, DP (B, L, R, T) with basic eco	354.9	113.0	350.3	108.49	125.2	475.5	3.8
	SU with pre-evap blank, small post-evap blank, DP (B, L, R, T) with std eco	378.9	113.0	374.3	108.49	125.2	499.5	11.4
	SU with pre-evap blank, large post-evap blank, DP (B, L, R, T) with basic eco	396.9	113.0	392.3	108.49	125.2	517.5	3.8
	SU with pre-evap blank, large post-evap blank, DP (B, L, R, T) with std eco	420.9	113.0	416.3	108.49	125.2	541.5	11.4
	SU with small post-evap blank, DP (B, L, R, T) with basic eco	301.9	113.0	297.3	108.49	125.2	422.5	3.8
	SU with small post-evap blank, DP (B, L, R, T) with std eco	325.9	113.0	321.3	108.49	125.2	446.5	11.4
	SU with large post-evap blank, DP (B, L, R, T) with basic eco	343.9	113.0	339.3	108.49	125.2	464.5	3.8
	SU with large post-evap blank, DP (B, L, R, T) with std eco	367.9	113.0	363.3	108.49	125.2	488.5	11.4
No heat + 74 in. SU	SU with pre-evap blank, small post-evap blank, DP (B, L, R, T) with basic eco	373.9	113.0	369.3	108.49	125.2	494.5	3.8
	SU with pre-evap blank, small post-evap blank, DP (B, L, R, T) with std eco	397.9	113.0	393.3	108.49	125.2	518.5	11.4
	SU with pre-evap blank, large post-evap blank, DP (B, L, R, T) with basic eco	415.9	113.0	411.3	108.49	125.2	536.5	3.8
	SU with pre-evap blank, large post-evap blank, DP (B, L, R, T) with std eco	439.9	113.0	435.3	108.49	125.2	560.5	11.4
	SU with small post-evap blank, DP (B, L, R, T) with basic eco	320.9	113.0	316.3	108.49	125.2	441.5	3.8
	SU with small post-evap blank, DP (B, L, R, T) with standard eco	344.9	113.0	340.3	108.49	125.2	465.5	11.4
	SU with large post-evap blank, DP (B, L, R, T) with basic eco	362.9	113.0	358.3	108.49	125.2	483.5	3.8
	SU with large post-evap blank, DP (B, L, R, T) with std eco	386.9	113.0	382.3	108.49	125.2	507.5	11.4

**Table 241: 70 ton to 80 ton left bottom return opening with bottom supply opening without ERW (in.)**

Unit configuration		AHU LG	Unit WD	AHU Curb LG	Curb WD	Cond LG	Total LG (E)	A
Heat	SU with vertical filter 4 in., with discharge through heat section (B, L) with basic eco	265.9	113.0	261.3	108.49	125.2	386.5	3.8
	SU with vertical filter 4 in., with discharge through heat section (B, L) with standard eco	289.9	113.0	285.3	108.49	125.2	410.5	11.4
	SU with discharge through heat section (B, L) with basic eco	282.9	113.0	278.3	108.49	125.2	403.5	3.8
	SU with discharge through heat section (B, L) with standard eco	306.9	113.0	302.3	108.49	125.2	427.5	11.4
	SU with heat, DP (B, L, R, T) with basic eco	328.9	113.0	324.3	108.49	125.2	449.5	3.8
	SU with heat, DP (B, L, R, T) with standard eco	352.9	113.0	348.3	108.49	125.2	473.5	11.4
	SU with pre-evap blank, discharge through heat section (B, L) with basic eco	335.9	113.0	331.3	108.49	125.2	456.5	3.8
	SU with pre-evap blank, discharge through heat section (B, L) with std eco	359.9	113.0	355.3	108.49	125.2	480.5	11.4
	SU with pre-evap blank, heat, DP (B, L, R, T) with basic eco	381.9	113.0	377.3	108.49	125.2	502.5	3.8
	SU with pre-evap blank, heat, DP (B, L, R, T) with std eco	405.9	113.0	401.3	108.49	125.2	526.5	11.4
	SU with pre-evap blank, heat, small post-evap blank, DP (B, L, R, T) with basic eco	426.9	113.0	422.3	108.49	125.2	547.5	3.8
	SU with pre-evap blank, heat, small post-evap blank, DP (B, L, R, T) with std eco	450.9	113.0	446.3	108.49	125.2	571.5	11.4
	SU with pre-evap blank, heat, large post-evap blank, DP (B, L, R, T) with basic eco	468.9	113.0	464.3	108.49	125.2	589.5	3.8
	SU with pre-evap blank, heat, large post-evap blank, DP (B, L, R, T) with std eco	492.9	113.0	488.3	108.49	125.2	613.5	11.4
	SU with heat, small post-evap blank, DP (B, L, R, T) with basic eco	373.9	113.0	369.3	108.49	125.2	494.5	3.8
	SU with heat, small post-evap blank, DP (B, L, R, T) with standard eco	397.9	113.0	393.3	108.49	125.2	518.5	11.4
	SU with heat, large post-evap blank, DP (B, L, R, T) with basic eco	415.9	113.0	411.3	108.49	125.2	536.5	3.8
	SU with heat, large post-evap blank, DP (B, L, R, T) with std eco	439.9	113.0	435.3	108.49	125.2	560.5	11.4

**Table 242: 70 ton to 80 ton left bottom return opening with bottom supply opening without ERW (in.)**

Unit configuration		B	RA WD	RA LG	C	D	SA LG	SA WD
No heat + 55 in. SU	SU with vertical filter 4 in., DP (B, L, R, T) with basic eco	62.6	65.0	54.3	-	17.2	40.0	74.0
	SU with vertical filter 4 in., DP (B, L, R, T) with standard eco	62.6	77.9	56.9	-	17.2	40.0	74.0
	SU with DP (B, L, R, T) with basic eco	62.6	65.0	54.3	-	17.2	40.0	74.0
	SU with DP (B, L, R, T) with standard eco	62.6	77.9	56.9	-	17.2	40.0	74.0
	SU with pre-evap blank, small post-evap blank, DP (B, L, R, T) with basic eco	62.6	65.0	54.3	-	17.2	40.0	74.0
	SU with pre-evap blank, small post-evap blank, DP (B, L, R, T) with std eco	62.6	77.9	56.9	-	17.2	40.0	74.0
	SU with pre-evap blank, large post-evap blank, DP (B, L, R, T) with basic eco	62.6	65.0	54.3	-	17.2	40.0	74.0
	SU with pre-evap blank, large post-evap blank, DP (B, L, R, T) with std eco	62.6	77.9	56.9	-	17.2	40.0	74.0
	SU with small post-evap blank, DP (B, L, R, T) with basic eco	62.6	65.0	54.3	-	17.2	40.0	74.0
	SU with small post-evap blank, DP (B, L, R, T) with std eco	62.6	77.9	56.9	-	17.2	40.0	74.0
	SU with large post-evap blank, DP (B, L, R, T) with basic eco	62.6	65.0	54.3	-	17.2	40.0	74.0
	SU with large post-evap blank, DP (B, L, R, T) with std eco	62.6	77.9	56.9	-	17.2	40.0	74.0
No heat + 74 in. SU	SU with pre-evap blank, small post-evap blank, DP (B, L, R, T) with basic eco	62.6	65.0	54.3	-	17.2	40.0	74.0
	SU with pre-evap blank, small post-evap blank, DP (B, L, R, T) with std eco	62.6	77.9	56.9	-	17.2	40.0	74.0
	SU with pre-evap blank, large post-evap blank, DP (B, L, R, T) with basic eco	62.6	65.0	54.3	-	17.2	40.0	74.0
	SU with pre-evap blank, large post-evap blank, DP (B, L, R, T) with std eco	62.6	77.9	56.9	-	17.2	40.0	74.0
	SU with small post-evap blank, DP (B, L, R, T) with basic eco	62.6	65.0	54.3	-	17.2	40.0	74.0
	SU with small post-evap blank, DP (B, L, R, T) with standard eco	62.6	77.9	56.9	-	17.2	40.0	74.0
	SU with large post-evap blank, DP (B, L, R, T) with basic eco	62.6	65.0	54.3	-	17.2	40.0	74.0
	SU with large post-evap blank, DP (B, L, R, T) with std eco	62.6	77.9	56.9	-	17.2	40.0	74.0

**Table 242: 70 ton to 80 ton left bottom return opening with bottom supply opening without ERW (in.)**

Unit configuration		B	RA WD	RA LG	C	D	SA LG	SA WD
Heat	SU with vertical filter 4 in., with discharge through heat section (B, L) with basic eco	62.6	65.0	54.3	4.2	24.3	40.0	60.0
	SU with vertical filter 4 in., with discharge through heat section (B, L) with standard eco	62.6	77.9	56.9	4.2	24.3	40.0	60.0
	SU with discharge through heat section (B, L) with basic eco	62.6	65.0	54.3	4.2	24.3	40.0	60.0
	SU with discharge through heat section (B, L) with standard eco	62.6	77.9	56.9	4.2	24.3	40.0	60.0
	SU with heat, DP (B, L, R, T) with basic eco	62.6	65.0	54.3	-	17.2	40.0	74.0
	SU with heat, DP (B, L, R, T) with standard eco	62.6	77.9	56.9	-	17.2	40.0	74.0
	SU with pre-evap blank, discharge through heat section (B, L) with basic eco	62.6	65.0	54.3	4.2	24.3	40.0	60.0
	SU with pre-evap blank, discharge through heat section (B, L) with std eco	62.6	77.9	56.9	4.2	24.3	40.0	60.0
	SU with pre-evap blank, heat, DP (B, L, R, T) with basic eco	62.6	65.0	54.3	-	17.2	40.0	74.0
	SU with pre-evap blank, heat, DP (B, L, R, T) with std eco	62.6	77.9	56.9	-	17.2	40.0	74.0
	SU with pre-evap blank, heat, small post-evap blank, DP (B, L, R, T) with basic eco	62.6	65.0	54.3	-	17.2	40.0	74.0
	SU with pre-evap blank, heat, small post-evap blank, DP (B, L, R, T) with std eco	62.6	77.9	56.9	-	17.2	40.0	74.0
	SU with pre-evap blank, heat, large post-evap blank, DP (B, L, R, T) with basic eco	62.6	65.0	54.3	-	17.2	40.0	74.0
	SU with pre-evap blank, heat, large post-evap blank, DP (B, L, R, T) with std eco	62.6	77.9	56.9	-	17.2	40.0	74.0
	SU with heat, small post-evap blank, DP (B, L, R, T) with basic eco	62.6	65.0	54.3	-	17.2	40.0	74.0
	SU with heat, small post-evap blank, DP (B, L, R, T) with standard eco	62.6	77.9	56.9	-	17.2	40.0	74.0
SU with heat, large post-evap blank, DP (B, L, R, T) with basic eco	62.6	65.0	54.3	-	17.2	40.0	74.0	
SU with heat, large post-evap blank, DP (B, L, R, T) with std eco	62.6	77.9	56.9	-	17.2	40.0	74.0	

**Note:**

For the 60 ton to 80 ton units, the basic economizer is available with the barometric damper. The standard economizer is available with the exhaust and return fan.

**Note:**

- AHU = Air Handling Unit, LG = Length, WD = Width, Cond = Condenser, RA = Return Air, RAR = RA Right, RAL = RA Left, SA = Supply Air
- SU = Standard Unit, DP = Discharge Plenum, B = Bottom, L = Left

**Figure 23: 60 ton to 80 ton roof curbs right bottom return opening and bottom supply opening without ERW**

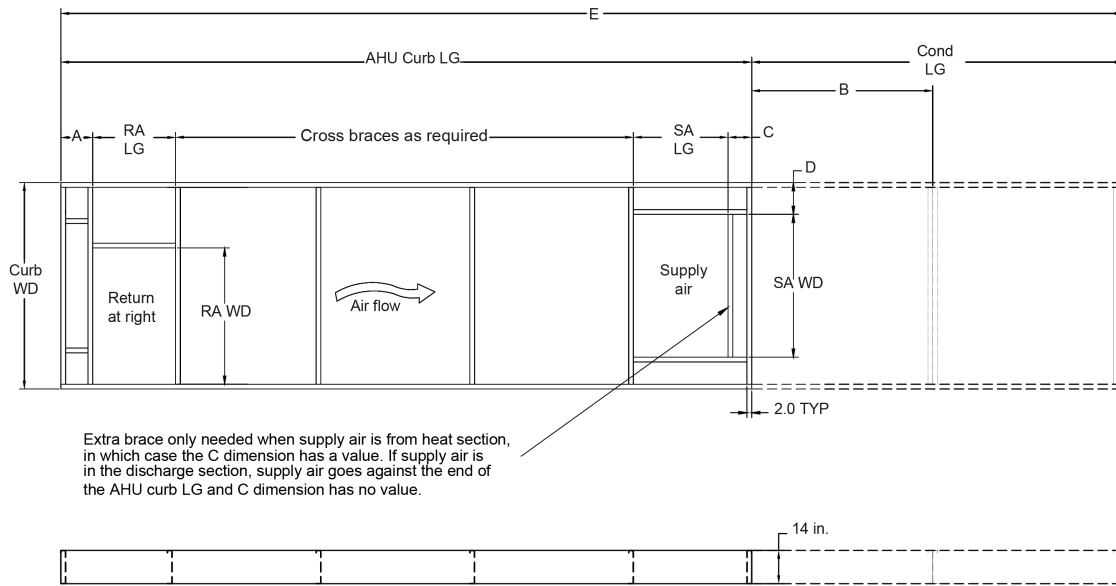

LD30034

**Table 243: 60 ton right bottom return opening with bottom supply opening without ERW (in.)**

Unit configuration		AHU LG	Unit WD	AHU Curb LG	Curb WD	Cond LG	Total LG (E)	A
No heat + 55 in. SU	SU with vertical filter 4 in., DP (B, L, R, T) with basic eco	201.4	113.0	196.8	108.49	97.2	294.0	3.8
	SU with vertical filter 4 in., DP (B, L, R, T) with standard eco	225.4	113.0	220.8	108.49	97.2	318.0	11.4
	SU with DP (B, L, R, T) with basic eco	218.4	113.0	213.8	108.49	97.2	311.0	3.8
	SU with DP (B, L, R, T) with standard eco	242.4	113.0	237.8	108.49	97.2	335.0	11.4
	SU with pre-evap blank, small post-evap blank, DP (B, L, R, T) with basic eco	316.4	113.0	311.8	108.49	97.2	409	3.8
	SU with pre-evap blank, small post-evap blank, DP (B, L, R, T) with standard eco	340.4	113.0	335.8	108.49	97.2	433	11.4
	SU with pre-evap blank, large post-evap blank, DP (B, L, R, T) with basic eco	358.4	113.0	353.8	108.49	97.2	451	3.8
	SU with pre-evap blank, large post-evap blank, DP (B, L, R, T) with standard eco	382.4	113.0	377.8	108.49	97.2	475	11.4
	SU with small post-evap blank, DP (B, L, R, T) with basic eco	263.4	113.0	258.8	108.49	97.2	356	3.8
	SU with small post-evap blank, DP (B, L, R, T) with standard eco	287.4	113.0	282.8	108.49	97.2	380	11.4
	SU with large post-evap blank, DP (B, L, R, T) with basic eco	305.4	113.0	300.8	108.49	97.2	398	3.8
SU with large post-evap blank, DP (B, L, R, T) with standard eco	329.4	113.0	324.8	108.49	97.2	422	11.4	

**Table 243: 60 ton right bottom return opening with bottom supply opening without ERW (in.)**

Unit configuration		AHU LG	Unit WD	AHU Curb LG	Curb WD	Cond LG	Total LG (E)	A
No heat + 74 in. SU	SU with pre-evap blank, small post-evap blank, DP (B, L, R, T) with basic eco	335.4	113.0	330.8	108.49	97.2	428	3.8
	SU with pre-evap blank, small post-evap blank, DP (B, L, R, T) with standard eco	359.4	113.0	354.8	108.49	97.2	452	11.4
	SU with pre-evap blank, large post-evap blank, DP (B, L, R, T) with basic eco	377.4	113.0	372.8	108.49	97.2	470	3.8
	SU with pre-evap blank, large post-evap blank, DP (B, L, R, T) with standard eco	401.4	113.0	396.8	108.49	97.2	494	11.4
	SU with small post-evap blank, DP (B, L, R, T) with basic eco	282.4	113.0	277.8	108.49	97.2	375.0	3.8
	SU with small post-evap blank, DP (B, L, R, T) with standard eco	306.4	113.0	301.8	108.49	97.2	399.0	11.4
	SU with large post-evap blank, DP (B, L, R, T) with basic eco	324.4	113.0	319.8	108.49	97.2	417	3.8
	SU with large post-evap blank, DP (B, L, R, T) with standard eco	348.4	113.0	343.8	108.49	97.2	441	11.4

**Table 243: 60 ton right bottom return opening with bottom supply opening without ERW (in.)**

Unit configuration		AHU LG	Unit WD	AHU Curb LG	Curb WD	Cond LG	Total LG (E)	A
Heat	SU with vertical filter 4 in., with discharge through heat section (B, L) with basic eco	237.4	113.0	232.8	108.49	97.2	330.0	3.8
	SU with vertical filter 4 in., with discharge through heat section (B, L) with standard eco	261.4	113.0	256.8	108.49	97.2	354.0	11.4
	SU with discharge through heat section (B, L) with basic eco	254.4	113.0	249.8	108.49	97.2	347.0	3.8
	SU with discharge through heat section (B, L) with standard eco	278.4	113.0	273.8	108.49	97.2	371.0	11.4
	SU with heat, DP (B, L, R, T) with basic eco	290.4	113.0	285.8	108.49	97.2	383.0	3.8
	SU with heat, DP (B, L, R, T) with standard eco	314.4	113.0	309.8	108.49	97.2	407.0	11.4
	SU with pre-evap blank, discharge through heat section (B, L) with basic eco	307.4	113.0	302.8	108.49	97.2	400	3.8
	SU with pre-evap blank, discharge through heat section (B, L) with standard eco	331.4	113.0	326.8	108.49	97.2	424	11.4
	SU with pre-evap blank, heat, DP (B, L, R, T) with basic eco	343.4	113.0	338.8	108.49	97.2	436	3.8
	SU with pre-evap blank, heat, DP (B, L, R, T) with standard eco	367.4	113.0	362.8	108.49	97.2	460	11.4
	SU with pre-evap blank, heat, small post-evap blank, DP (B, L, R, T) with basic eco	388.4	113.0	383.8	108.49	97.2	481	3.8
	SU with pre-evap blank, heat, small post-evap blank, DP (B, L, R, T) with standard eco	412.4	113.0	407.8	108.49	97.2	505	11.4
	SU with pre-evap blank, heat, large post-evap blank, DP (B, L, R, T) with basic eco	430.4	113.0	425.8	108.49	97.2	523	3.8
	SU with pre-evap blank, heat, large post-evap blank, DP (B, L, R, T) with standard eco	454.4	113.0	449.8	108.49	97.2	547	11.4
	SU with heat, small post-evap blank, DP (B, L, R, T) with basic eco	335.4	113.0	330.8	108.49	97.2	428.0	3.8
	SU with heat, small post-evap blank, DP (B, L, R, T) with standard eco	359.4	113.0	354.8	108.49	97.2	452.0	11.4
	SU with heat, large post-evap blank, DP (B, L, R, T) with basic eco	377.4	113.0	372.8	108.49	97.2	470	3.8
	SU with heat, large post-evap blank, DP (B, L, R, T) with standard eco	401.4	113.0	396.8	108.49	97.2	494	11.4

**Table 244: 60 ton right bottom return opening with bottom supply opening without ERW (in.)**

Unit configuration		B	RA WD	RA LG	C	D	SA LG	SA WD
No heat + 55 in. SU	SU with vertical filter 4 in., DP (B, L, R, T) with basic eco	48.6	65.0	54.3	-	17.2	30.0	74.0
	SU with vertical filter 4 in., DP (B, L, R, T) with standard eco	48.6	77.9	56.9	-	17.2	30.0	74.0
	SU with DP (B, L, R, T) with basic eco	48.6	65.0	54.3	-	17.2	30.0	74.0
	SU with DP (B, L, R, T) with standard eco	48.6	77.9	56.9	-	17.2	30.0	74.0
	SU with pre-evap blank, small post-evap blank, DP (B, L, R, T) with basic eco	48.6	65.0	54.3	-	17.2	30.0	74.0
	SU with pre-evap blank, small post-evap blank, DP (B, L, R, T) with standard eco	48.6	77.9	56.9	-	17.2	30.0	74.0
	SU with pre-evap blank, large post-evap blank, DP (B, L, R, T) with basic eco	48.6	65.0	54.3	-	17.2	30.0	74.0
	SU with pre-evap blank, large post-evap blank, DP (B, L, R, T) with standard eco	48.6	77.9	56.9	-	17.2	30.0	74.0
	SU with small post-evap blank, DP (B, L, R, T) with basic eco	48.6	65.0	54.3	-	17.2	30.0	74.0
	SU with small post-evap blank, DP (B, L, R, T) with standard eco	48.6	77.9	56.9	-	17.2	30.0	74.0
	SU with large post-evap blank, DP (B, L, R, T) with basic eco	48.6	65.0	54.3	-	17.2	30.0	74.0
	SU with large post-evap blank, DP (B, L, R, T) with standard eco	48.6	77.9	56.9	-	17.2	30.0	74.0
No heat + 74 in. SU	SU with pre-evap blank, small post-evap blank, DP (B, L, R, T) with basic eco	48.6	65.0	54.3	-	17.2	30.0	74.0
	SU with pre-evap blank, small post-evap blank, DP (B, L, R, T) with standard eco	48.6	77.9	56.9	-	17.2	30.0	74.0
	SU with pre-evap blank, large post-evap blank, DP (B, L, R, T) with basic eco	48.6	65.0	54.3	-	17.2	30.0	74.0
	SU with pre-evap blank, large post-evap blank, DP (B, L, R, T) with standard eco	48.6	77.9	56.9	-	17.2	30.0	74.0
	SU with small post-evap blank, DP (B, L, R, T) with basic eco	48.6	65.0	54.3	-	17.2	30.0	74.0
	SU with small post-evap blank, DP (B, L, R, T) with standard eco	48.6	77.9	56.9	-	17.2	30.0	74.0
	SU with large post-evap blank, DP (B, L, R, T) with basic eco	48.6	65.0	54.3	-	17.2	30.0	74.0
	SU with large post-evap blank, DP (B, L, R, T) with standard eco	48.6	77.9	56.9	-	17.2	30.0	74.0

**Table 244: 60 ton right bottom return opening with bottom supply opening without ERW (in.)**

Unit configuration		B	RA WD	RA LG	C	D	SA LG	SA WD
Heat	SU with vertical filter 4 in., with discharge through heat section (B, L) with basic eco	48.6	65.0	54.3	4.2	24.3	40.0	60.0
	SU with vertical filter 4 in., with discharge through heat section (B, L) with standard eco	48.6	77.9	56.9	4.2	24.3	40.0	60.0
	SU with discharge through heat section (B, L) with basic eco	48.6	65.0	54.3	4.2	24.3	40.0	60.0
	SU with discharge through heat section (B, L) with standard eco	48.6	77.9	56.9	4.2	24.3	40.0	60.0
	SU with heat, DP (B, L, R, T) with basic eco	48.6	65.0	54.3	-	17.2	30.0	74.0
	SU with heat, DP (B, L, R, T) with standard eco	48.6	77.9	56.9	-	17.2	30.0	74.0
	SU with pre-evap blank, discharge through heat section (B, L) with basic eco	48.6	65.0	54.3	4.2	24.3	40.0	60.0
	SU with pre-evap blank, discharge through heat section (B, L) with standard eco	48.6	77.9	56.9	4.2	24.3	40.0	60.0
	SU with pre-evap blank, heat, DP (B, L, R, T) with basic eco	48.6	65.0	54.3	-	17.2	30.0	74.0
	SU with pre-evap blank, heat, DP (B, L, R, T) with standard eco	48.6	77.9	56.9	-	17.2	30.0	74.0
	SU with pre-evap blank, heat, small post-evap blank, DP (B, L, R, T) with basic eco	48.6	65.0	54.3	-	17.2	30.0	74.0
	SU with pre-evap blank, heat, small post-evap blank, DP (B, L, R, T) with standard eco	48.6	77.9	56.9	-	17.2	30.0	74.0
	SU with pre-evap blank, heat, large post-evap blank, DP (B, L, R, T) with basic eco	48.6	65.0	54.3	-	17.2	30.0	74.0
	SU with pre-evap blank, heat, large post-evap blank, DP (B, L, R, T) with standard eco	48.6	77.9	56.9	-	17.2	30.0	74.0
	SU with heat, small post-evap blank, DP (B, L, R, T) with basic eco	48.6	65.0	54.3	-	17.2	30.0	74.0
	SU with heat, small post-evap blank, DP (B, L, R, T) with standard eco	48.6	77.9	56.9	-	17.2	30.0	74.0
	SU with heat, large post-evap blank, DP (B, L, R, T) with basic eco	48.6	65.0	54.3	-	17.2	30.0	74.0
	SU with heat, large post-evap blank, DP (B, L, R, T) with standard eco	48.6	77.9	56.9	-	17.2	30.0	74.0

**Table 245: 70 ton to 80 ton right bottom return opening with bottom supply opening without ERW (in.)**

Unit Configuration		AHU LG	Unit WD	AHU Curb LG	Curb WD	Cond LG	Total LG (E)	A
No heat + 55 in. SU	SU with vertical filter 4 in., DP (B, L, R, T) with basic eco	239.9	113.0	235.3	108.49	125.2	360.5	3.8
	SU with vertical filter 4 in., DP (B, L, R, T) with standard eco	263.9	113.0	259.3	108.49	125.2	384.5	11.4
	SU with DP (B, L, R, T) with basic eco	256.9	113.0	252.3	108.49	125.2	377.5	3.8
	SU with DP (B, L, R, T) with standard eco	280.9	113.0	276.3	108.49	125.2	401.5	11.4
	SU with pre-evap blank, small post-evap blank, DP (B, L, R, T) with basic eco	354.9	113.0	350.3	108.49	125.2	475.5	3.8
	SU with pre-evap blank, small post-evap blank, DP (B, L, R, T) with standard eco	378.9	113.0	374.3	108.49	125.2	499.5	11.4
	SU with pre-evap blank, large post-evap blank, DP (B, L, R, T) with basic eco	396.9	113.0	392.3	108.49	125.2	517.5	3.8
	SU with pre-evap blank, large post-evap blank, DP (B, L, R, T) with standard eco	420.9	113.0	416.3	108.49	125.2	541.5	11.4
	SU with small post-evap blank, DP (B, L, R, T) with basic eco	301.9	113.0	297.3	108.49	125.2	422.5	3.8
	SU with small post-evap blank, DP (B, L, R, T) with standard eco	325.9	113.0	321.3	108.49	125.2	446.5	11.4
	SU with large post-evap blank, DP (B, L, R, T) with basic eco	343.9	113.0	339.3	108.49	125.2	464.5	3.8
	SU with large post-evap blank, DP (B, L, R, T) with standard eco	367.9	113.0	363.3	108.49	125.2	488.5	11.4
No heat + 74 in. SU	SU with pre-evap blank, small post-evap blank, DP (B, L, R, T) with basic eco	373.9	113.0	369.3	108.49	125.2	494.5	3.8
	SU with pre-evap blank, small post-evap blank, DP (B, L, R, T) with standard eco	397.9	113.0	393.3	108.49	125.2	518.5	11.4
	SU with pre-evap blank, large post-evap blank, DP (B, L, R, T) with basic eco	415.9	113.0	411.3	108.49	125.2	536.5	3.8
	SU with pre-evap blank, large post-evap blank, DP (B, L, R, T) with standard eco	439.9	113.0	435.3	108.49	125.2	560.5	11.4
	SU with small post-evap blank, DP (B, L, R, T) with basic eco	320.9	113.0	316.3	108.49	125.2	441.5	3.8
	SU with small post-evap blank, DP (B, L, R, T) with standard eco	344.9	113.0	340.3	108.49	125.2	465.5	11.4
	SU with large post-evap blank, DP (B, L, R, T) with basic eco	362.9	113.0	358.3	108.49	125.2	483.5	3.8
	SU with large post-evap blank, DP (B, L, R, T) with standard eco	386.9	113.0	382.3	108.49	125.2	507.5	11.4

**Table 245: 70 ton to 80 ton right bottom return opening with bottom supply opening without ERW (in.)**

Unit Configuration		AHU LG	Unit WD	AHU Curb LG	Curb WD	Cond LG	Total LG (E)	A
Heat	SU with vertical filter 4 in., with discharge through heat section (B, L) with basic eco	265.9	113.0	261.3	108.49	125.2	386.5	3.8
	SU with vertical filter 4 in., with discharge through heat section (B, L) with standard eco	289.9	113.0	285.3	108.49	125.2	410.5	11.4
	SU with discharge through heat section (B, L) with basic eco	282.9	113.0	278.3	108.49	125.2	403.5	3.8
	SU with discharge through heat section (B, L) with standard eco	306.9	113.0	302.3	108.49	125.2	427.5	11.4
	SU with heat, DP (B, L, R, T) with basic eco	328.9	113.0	324.3	108.49	125.2	449.5	3.8
	SU with heat, DP (B, L, R, T) with standard eco	352.9	113.0	348.3	108.49	125.2	473.5	11.4
	SU with pre-evap blank, discharge through heat section (B, L) with basic eco	335.9	113.0	331.3	108.49	125.2	456.5	3.8
	SU with pre-evap blank, discharge through heat section (B, L) with standard eco	359.9	113.0	355.3	108.49	125.2	480.5	11.4
	SU with pre-evap blank, heat, DP (B, L, R, T) with basic eco	381.9	113.0	377.3	108.49	125.2	502.5	3.8
	SU with pre-evap blank, heat, DP (B, L, R, T) with standard eco	405.9	113.0	401.3	108.49	125.2	526.5	11.4
	SU with pre-evap blank, heat, small post-evap blank, DP (B, L, R, T) with basic eco	426.9	113.0	422.3	108.49	125.2	547.5	3.8
	SU with pre-evap blank, heat, small post-evap blank, DP (B, L, R, T) with standard eco	450.9	113.0	446.3	108.49	125.2	571.5	11.4
	SU with pre-evap blank, heat, large post-evap blank, DP (B, L, R, T) with basic eco	468.9	113.0	464.3	108.49	125.2	589.5	3.8
	SU with pre-evap blank, heat, large post-evap blank, DP (B, L, R, T) with standard eco	492.9	113.0	488.3	108.49	125.2	613.5	11.4
	SU with heat, small post-evap blank, DP (B, L, R, T) with basic eco	373.9	113.0	369.3	108.49	125.2	494.5	3.8
	SU with heat, small post-evap blank, DP (B, L, R, T) with standard eco	397.9	113.0	393.3	108.49	125.2	518.5	11.4
	SU with heat, large post-evap blank, DP (B, L, R, T) with basic eco	415.9	113.0	411.3	108.49	125.2	536.5	3.8
	SU with heat, large post-evap blank, DP (B, L, R, T) with standard eco	439.9	113.0	435.3	108.49	125.2	560.5	11.4

**Table 246: 70 ton to 80 ton right bottom return opening with bottom supply opening without ERW (in.)**

Unit configuration		B	RA WD	RA LG	C	D	SA LG	SA WD
No heat + 55 in. SU	SU with vertical filter 4 in., DP (B, L, R, T) with basic eco	62.6	65.0	54.3	-		17.2	40.0
	SU with vertical filter 4 in., DP (B, L, R, T) with standard eco	62.6	77.9	56.9	-	17.2	40.0	74.0
	SU with DP (B, L, R, T) with basic eco	62.6	65.0	54.3	-	17.2	40.0	74.0
	SU with DP (B, L, R, T) with standard eco	62.6	77.9	56.9	-	17.2	40.0	74.0
	SU with pre-evap blank, small post-evap blank, DP (B, L, R, T) with basic eco	62.6	65.0	54.3	-	17.2	40.0	74.0
	SU with pre-evap blank, small post-evap blank, DP (B, L, R, T) with standard eco	62.6	77.9	56.9	-	17.2	40.0	74.0
	SU with pre-evap blank, large post-evap blank, DP (B, L, R, T) with basic eco	62.6	65.0	54.3	-	17.2	40.0	74.0
	SU with pre-evap blank, large post-evap blank, DP (B, L, R, T) with standard eco	62.6	77.9	56.9	-	17.2	40.0	74.0
	SU with small post-evap blank, DP (B, L, R, T) with basic eco	62.6	65.0	54.3	-	17.2	40.0	74.0
	SU with small post-evap blank, DP (B, L, R, T) with standard eco	62.6	77.9	56.9	-	17.2	40.0	74.0
	SU with large post-evap blank, DP (B, L, R, T) with basic eco	62.6	65.0	54.3	-	17.2	40.0	74.0
	SU with large post-evap blank, DP (B, L, R, T) with standard eco	62.6	77.9	56.9	-	17.2	40.0	74.0
No heat + 74 in. SU	SU with pre-evap blank, small post-evap blank, DP (B, L, R, T) with basic eco	62.6	65.0	54.3	-	17.2	40.0	74.0
	SU with pre-evap blank, small post-evap blank, DP (B, L, R, T) with standard eco	62.6	77.9	56.9	-	17.2	40.0	74.0
	SU with pre-evap blank, large post-evap blank, DP (B, L, R, T) with basic eco	62.6	65.0	54.3	-	17.2	40.0	74.0
	SU with pre-evap blank, large post-evap blank, DP (B, L, R, T) with standard eco	62.6	77.9	56.9	-	17.2	40.0	74.0
	SU with small post-evap blank, DP (B, L, R, T) with basic eco	62.6	65.0	54.3	-	17.2	40.0	74.0
	SU with small post-evap blank, DP (B, L, R, T) with standard eco	62.6	77.9	56.9	-	17.2	40.0	74.0
	SU with large post-evap blank, DP (B, L, R, T) with basic eco	62.6	65.0	54.3	-	17.2	40.0	74.0
	SU with large post-evap blank, DP (B, L, R, T) with standard eco	62.6	77.9	56.9	-	17.2	40.0	74.0

**Table 246: 70 ton to 80 ton right bottom return opening with bottom supply opening without ERW (in.)**

Unit configuration		B	RA WD	RA LG	C	D	SA LG	SA WD
Heat	SU with vertical filter 4 in., with discharge through heat section (B, L) with basic eco	62.6	65.0	54.3	4.2	24.3	40.0	60.0
	SU with vertical filter 4 in., with discharge through heat section (B, L) with standard eco	62.6	77.9	56.9	4.2	24.3	40.0	60.0
	SU with discharge through heat section (B, L) with basic eco	62.6	65.0	54.3	4.2	24.3	40.0	60.0
	SU with discharge through heat section (B, L) with standard eco	62.6	77.9	56.9	4.2	24.3	40.0	60.0
	SU with heat, DP (B, L, R, T) with basic eco	62.6	65.0	54.3	-	17.2	40.0	74.0
	SU with heat, DP (B, L, R, T) with standard eco	62.6	77.9	56.9	-	17.2	40.0	74.0
	SU with pre-evap blank, discharge through heat section (B, L) with basic eco	62.6	65.0	54.3	-	17.2	40.0	74.0
	SU with pre-evap blank, discharge through heat section (B, L) with standard eco	62.6	77.9	56.9	-	17.2	40.0	74.0
	SU with pre-evap blank, heat, DP (B, L, R, T) with basic eco	62.6	65.0	54.3	-	17.2	40.0	74.0
	SU with pre-evap blank, heat, DP (B, L, R, T) with standard eco	62.6	77.9	56.9	-	17.2	40.0	74.0
	SU with pre-evap blank, heat, small post-evap blank, DP (B, L, R, T) with basic eco	62.6	65.0	54.3	-	17.2	40.0	74.0
	SU with pre-evap blank, heat, small post-evap blank, DP (B, L, R, T) with standard eco	62.6	77.9	56.9	-	17.2	40.0	74.0
	SU with pre-evap blank, heat, large post-evap blank, DP (B, L, R, T) with basic eco	62.6	65.0	54.3	-	17.2	40.0	74.0
	SU with pre-evap blank, heat, large post-evap blank, DP (B, L, R, T) with standard eco	62.6	77.9	56.9	-	17.2	40.0	74.0
	SU with heat, small post-evap blank, DP (B, L, R, T) with basic eco	62.6	65.0	54.3	-	17.2	40.0	74.0
	SU with heat, small post-evap blank, DP (B, L, R, T) with standard eco	62.6	77.9	56.9	-	17.2	40.0	74.0
	SU with heat, large post-evap blank, DP (B, L, R, T) with basic eco	62.6	65.0	54.3	-	17.2	40.0	74.0
	SU with heat, large post-evap blank, DP (B, L, R, T) with standard eco	62.6	77.9	56.9	-	17.2	40.0	74.0

**Note:**

For the 60 ton to 80 ton units, the basic economizer is available with the barometric damper. The standard economizer is available with the exhaust and return fan.

**Note:**

- AHU = Air Handling Unit, LG = Length, WD = Width, Cond = Condenser, RA = Return Air, RAR = RA Right, RAL = RA Left, SA = Supply Air
- SU = Standard Unit, DP = Discharge Plenum, B = Bottom, L = Left

# Supply and return air duct configurations

**Figure 24: Air duct configurations**

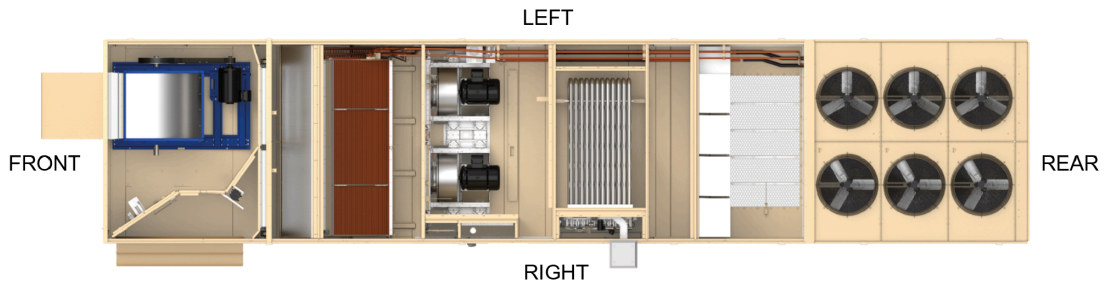

LD30035

**Table 247: 25 ton to 80 ton supply and return air duct configurations**

Unit configuration	Supply air				Return air					Outside air		Exhaust air	
	Bottom	Left	Right	Top	Bottom	Left	Right	Top	Front	Left	Right	Side*	Front
Cooling only	Yes	Yes	Yes	Yes	-	Yes	-	-	-	-	Yes	-	Yes
	Yes	Yes	Yes	Yes	-	-	Yes	-	-	Yes	-	-	Yes
	Yes	Yes	Yes	Yes	Yes	-	-	Yes	-	Yes	Yes	Yes	Yes
	Yes	Yes	Yes	Yes	-	-	-	-	Yes	Yes	Yes	Yes	-
Cooling with discharge through heat section	Yes	Yes	-	-	-	Yes	-	-	-	-	Yes	-	Yes
	Yes	Yes	-	-	-	-	Yes	-	-	Yes	-	-	Yes
	Yes	Yes	-	-	Yes	-	-	Yes	-	Yes	Yes	Yes	Yes
	Yes	Yes	-	-	-	-	-	-	Yes	Yes	Yes	Yes	-
Cooling with heat and discharge plenum or cooling with downstream section and discharge plenum	Yes	Yes	Yes	Yes	-	Yes	-	-	-	-	Yes	-	Yes
	Yes	Yes	Yes	Yes	-	-	Yes	-	-	Yes	-	-	Yes
	Yes	Yes	Yes	Yes	Yes	-	-	Yes	-	Yes	Yes	Yes	Yes
	Yes	Yes	Yes	Yes	-	-	-	-	Yes	Yes	Yes	Yes	-
Cooling with ERW and discharge through heat section	Yes	Yes	-	-	Yes	-	-	-	-	-	Yes	Yes	Yes
Cooling with heat with ERW with downstream section and discharge plenum	Yes	Yes	Yes	Yes	Yes	-	-	-	-	-	Yes	Yes	Yes

**Note:**

- \*Exhaust air side is opposite of outside air side.
- Top return with return fan or ERW is not available.

## Unit clearances

The Premier units are designed for outdoor installation. When selecting a site for installation, consider the following conditions:

- The unit must be installed on a level surface.
- For units located outside, select a place with minimum sun exposure and an adequate supply of fresh air for the condenser.
- Avoid locations beneath windows or between structures.
- Select optional condenser coil protection for locations in proximity to salt water or other harsh environments.

- Install the unit on a roof that is structurally strong enough to support the weight of the unit with minimal deflection. It is recommended that the unit(s) be installed no more than 15 ft from a main support beam to provide proper structural support and to minimize the transmission of sound and vibration. Ideally, the center of gravity must be located over a structural support or building column.
- Locate unit(s) away from building flue stacks or exhaust ventilators to prevent possible reintroduction of contaminated air through the outside air intakes.
- Ensure the supporting structures do not obstruct the duct, gas, or wiring connections.
- Proper operational and service clearance space around the perimeter of the unit, on one side for coil servicing, and to any adjacent units is required to ensure unit performance, eliminate cross contamination of exhaust and outside air, and for maintenance tasks, such as coil pull and cleaning. There must be no obstructions above the condensing unit section.
- As shown condenser clearance varies based on unit tonnage and coil arrangements.

**Figure 25: Unit clearances**

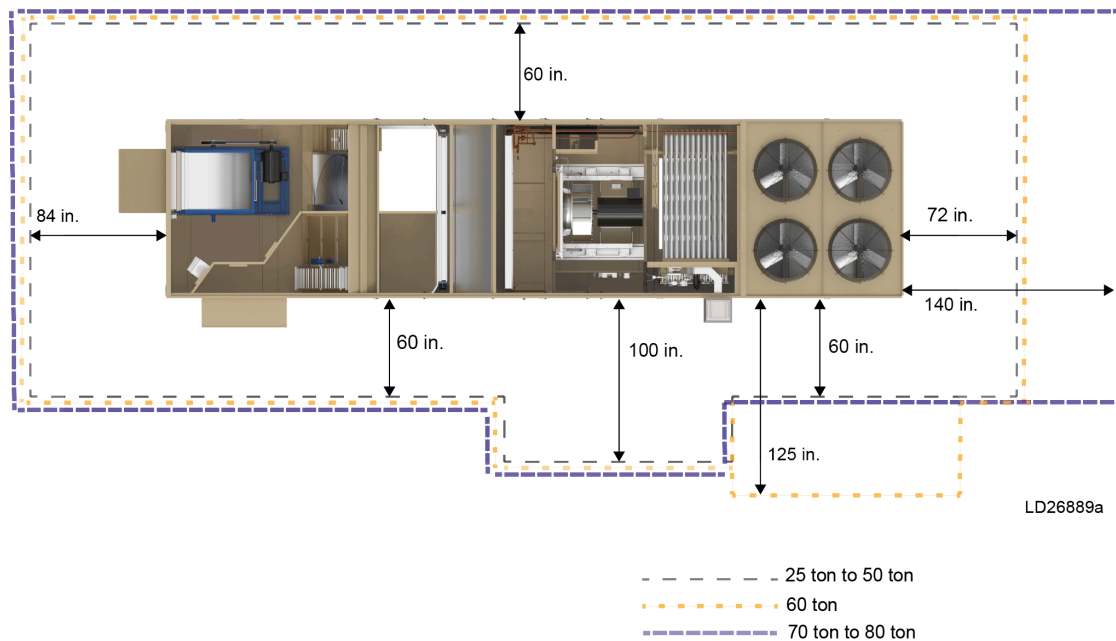

**Note:**

1. 10 ft clearance minimum over the top of the condensing unit.
2. Only one adjacent wall can exceed unit height.
3. 12 ft clearance required to adjacent units.

**Location**

Of the many factors that can affect the location of equipment, some of the most important to consider are structural, acoustical, and service clearances. Give proper attention during the design stage to ensure proper structural support. In cases where equipment is being replaced, be aware of building design to ensure support is adequate for the application.

Sound from the equipment is an important consideration when applying the unit equipment to a space. Ensure the unit is kept away from

sound sensitive areas, such as conference rooms, auditoriums, executive offices, and any other rooms that may potentially occupy tenants. Possible locations to install a single package unit could include above hallways or mechanical or utility rooms. Refer to the *Sound from Rooftop Units Application Guide (Form 5515909-JAD)*.

## Unit placement

- **Elevated** - Elevated roof curbs or dunnage steel can be used to support the unit in order to raise it to specific heights. When this type of placement is required, keep unit access in mind. Cat walks or other forms of unit access may be required to one or both sides of the unit depending on your area of the country and the local codes that are enforced. Please check with local officials to ensure the application conforms to local codes and regulations.
- **Ground level locations** - It is important that the units are installed on a substantial base that does not settle or cause strain on the refrigerant lines and sheet metal that could result in possible leaks. A one-piece concrete slab with footers extended below the frost line is highly recommended. Additionally, isolate the slab from the main building foundation to prevent noise and vibration transmission to the building structure. For ground level installations, take precautions to protect the unit from tampering by or injury to unauthorized persons. Make accommodations that allow for the proper depths of the drain pan trap and humidifier trap. Service clearances must be maintained at all times. For further details, refer to the *Variable Air Volume for Roof Curbs for Rooftop Units Application Guide (Form 5553807-JAD)*.

# Guide specifications

## General

[Available options are shown in brackets.]

### Scope

The requirements of the General Conditions, Supplementary Conditions, Division 1, and drawings apply to all work herein.

Provide specifications for the following features:

- Microprocessor controlled, multiple-scroll compressor.
- Air-cooled, double wall outdoor packaged rooftop air conditioning units.
- Components of the scheduled capacities and performance, as shown and indicated on the drawings, including but not limited to: factory-single packaged air conditioner; charge of refrigerant and oil; roof curb; field duct; power and control connections; and utility connections.

### Quality assurance

All units are tested, rated, or certified, as applicable, in accordance with the following standards, guidelines, and codes:

1. All units meet ASHRAE 90.1-2019 minimum energy efficiency ratio/integrated energy efficiency ratio (EER/IEER).
2. All units comply with ASHRAE 189.1-2014 EER/IEER efficiency requirements.
3. All units meet the latest ASHRAE 62 requirements for ventilation and indoor air quality (IAQ).
4. All units are rated in accordance with the AHRI Standard 340/360. Units greater than 63 tons are excluded from the AHRI certification program.
5. All units are certified to UL 60335-2-40.
6. All units meet the 2023 Department of Energy efficiency code.
7. All gas heating units are designed in conformance to ANSI Z83.8-2016/CSA 2.6-2016 standards and carry a CSA listing.
8. All units' outdoor sound data are rated in accordance with ANSI/AHRI 370-2015 *Sound Performance Rating of Large Air-Cooled Outdoor Refrigerating and Air-Conditioning Equipment*.
9. All units' indoor sound data are rated in accordance with the ANSI/AHRI 260-2017 *Sound Rating of Ducted Air Moving and Conditioning Equipment*.

## Manufacturers

The design shown on the drawing is based upon products of the scheduled manufacturer. Alternate equipment manufacturers are acceptable if equipment meets the scheduled performance and complies with these specifications. If equipment supplied by manufacturer other than that scheduled is utilized, then the mechanical contractor is responsible for coordinating with the general contractor and all affected subcontractors to ensure proper provisions for installation of the furnished unit. This coordination includes, but is not limited to, the following:

1. Structural supports for units.
2. A prefabricated, heavy gauge galvanized steel mounting curb, designed and supplied by the unit manufacturer, is provided for field assembly on the roof decking prior to unit shipment. The roof curb is a partial [full] perimeter type with complete perimeter support of the air handling section and rail support of the condensing section. Supply and return opening duct frames are provided as part of the curb structure, allowing duct connections to be made directly to the curb prior to unit arrival. The curb is a minimum of 14 in. high and include a nominal 2 in. x 4 in. wood nailing strip. Gasket is provided for field mounting between the unit base and roof curb.
3. Piping size and connection or header locations.
4. Electrical power requirements and wire or conduit and overcurrent protection sizes.
5. All costs incurred to modify the building provisions to accept the furnished units.

## Warranty

### Unit warranty

The manufacturer warrants all equipment and material of its manufacture against defects in workmanship and material for a period of 12 months from start-up or 18 months from date of shipment, whichever occurs first. Extended warranty is provided to cover the unit for [24] [60] months from the date of shipment.

- The warranty includes parts [and labor] during this period only.
- The warranty does not include parts associated with routine maintenance, such as belts, air filters, etc.

## Compressor warranty

The manufacturer warrants all compressors against defects in workmanship and material for a period of 12 [60] months from date of shipment.

- The warranty includes parts [and labor] during this period only.
- The warranty does not include parts associated with routine maintenance.

## Gas heat exchanger warranty [optional]

The manufacturer warrants all stainless steel gas heat exchangers against defects in workmanship and material for a period of 120 months from date of shipment.

- The warranty includes parts during this period only.
- The warranty does not include parts associated with routine maintenance.

## Delivery and handling

1. The unit is delivered to the job site fully assembled, wired, and charged with refrigerant and oil by the manufacturer.
2. **Split ship [optional for units less than 53 feet long]** Unit is factory tested and delivered to the job site split in two segments, air handling and condensing section, for field assembly and installation. Unit segments ship with valves on each end to recouple the unit and pre-charged with R-410A refrigerant to minimize field setup time. An electrical box is provided in the condensing section to seamlessly integrate power to the unit. The contractor covers the cost of refrigerant, evacuation and charge time for units that are not pre-charged with refrigerant.
3. All handling and storage procedures are per the manufacturer's recommendations.

## Submittals

### Shop drawings

Shop drawing submittals include, but are not limited to, the following: drawings indicating components, dimensions, weights, required clearances, location, type and size of field connections, and power and control wiring connections.

### Product data

Product data includes dimensions, weights, capacities, ratings, fan performance, motor electrical characteristics, and gauges and finishes of materials.

## Documentation

1. Fan curves with specified operating point clearly plotted are provided.
2. Product data of filter media, filter performance data, filter assembly, and filter frames is provided.
3. Electrical requirements for power supply wiring, including wiring diagrams for interlock and control wiring are supplied. Factory and field-installed wiring are clearly indicated.

## Equipment

### Product specification

#### Summary

Completely factory assembled, unitized construction [delivered to the job site split in two segments], single packaged air conditioning unit including a factory-mounted and wired unit controller and sensors; single point power with terminal block [dual point power with terminal block] [a non-fused electrical disconnect] [a fused electrical disconnect], for main unit power is factory-installed 460 V [208 V to 230 V][575 V] power supply, outside air handling section with return and supply openings, discharge air (DA) plenum, direct-expansion refrigerant condensing section. 5 kA [65 kA] short-circuit current rating (SCCR).

#### Phase monitor

A phase monitor is provided on unit designed to protect 3 phase equipment from phase loss, reversal, imbalance, and low voltage. The phase monitor fault condition is indicated at the unit control panel, and the unit is placed into an emergency stop condition.

#### Internal lights [optional]

A 115 V circuit of centrally located marine LED lights is provided with individual wiring run from the single switch located in the low voltage power supply panel common wall. At a minimum lights are provided in the [pre-evaporator blank] [post-evaporator blank] economizer, evaporator coil, and supply fan sections.

#### Factory test

1. On factory-assembled or split ship units, the refrigerant circuit is pressure-tested, evacuated, and fully charged with refrigerant and oil.
2. On factory-assembled or split ship units, the unit controller is configured and run tested at the factory to minimize field setup time.

3. If the unit is not configured and tested, then the manufacturer provides field start-up and testing to ensure that the controller is functioning correctly.
4. Record test reports [optional] include end of line quality test report to be sent out to the customer.
5. Rooftop unit is tested and certified to meet the seismic standards [optional] of the International Building Code and ASCE 7-06. Unit is approved for seismic application when properly installed, used as intended, and contains a Seismic Certification Label referencing the Certificate of Compliance. As limited by the tabulated values, below grade, grade, and roof-level installations, installations in essential facilities, for life safety applications, and of equipment containing hazardous contents are permitted and included in this certification with an Equipment Importance Factor assigned as IP=1.5, certified to a maximum Design Structural Response Acceleration at Short Periods (Sds) of up to 1.4 g. Unit is labelled to reflect this.

#### Unit construction

**Base rail** - The unit includes an integral design base rail with lifting points clearly marked and visible on the base rail and a 1 1/4 in. female pipe thread (FPT) connection for condensate drainage. The unit base is designed with a recessed curb mounting location. The recessed curb mounting surface provides a continuous surface for field application of curb gasketing to create a weather-tight seal between the curb and unit.

**Unit casing** - Unit casing has a double wall insulation with injected foam. Insulation application meets NFPA 90 requirements. The insulation system is resistant to mold growth in accordance with UL 181 and ASTM C1338 standardized test methods.

**Paint** - Exterior champagne color painted surfaces are designed to withstand a minimum of 750 salt spray hours when tested in accordance with ASTM B-117.

**Markings and diagrams** - All necessary tags and decals to aid in the service or indicating caution areas are provided. Electrical ladder wiring diagrams are attached to the control panel access door.

**Documentation** - Installation and maintenance manuals are supplied with each unit.

**Access doors** - Double wall access doors are provided in the fan, [discharge] coil, filter, and inlet sections. Doors are double wall construction with a solid liner and a minimum thickness of 1 in. Doors are attached to the unit with stainless steel hinges. A minimum of three 5/16 in. hex-drive, 90° opening

standard finger pull latches are provided. [Viewports are provided in the supply fan, economizer, and cooling coil sections.] [Latches are single handle rotary type with minimum three point contact and an adjustable height handle. Padlockable handle is provided.]

Panels and doors are completely gasketed with a closed-cell, neoprene gasket. Door tiebacks are provided for all doors to secure them while servicing. Doors that provide access to positive pressure segments include a safety latch. The safety latch relieves pressure if inadvertently opened during unit operation. [Doors that provide access to the ultraviolet (UV) light section include an electrical switch that disables UV light operation when the door is opened.]

**Burglar bars [optional]** - Burglar bars are mounted in the [supply] [return] [supply and return] opening to prevent entry into the building through the ductwork. Burglar bars are provided for accessible sections with a bottom opening.

## Economizer section

ⓘ **Note:** Select either no outside air or economizer.

1. **No outside air** - The unit has no provisions for outside ventilation air.
2. **Modulating economizer** - The economizer segment is designed to use outside air for cooling, ventilation, and provides a means of exhausting air from the air handling unit. The segment consists of parallel-acting low leak [ultra low leak] dampers. The outside air (OA) and exhaust air (EA) dampers are sized for 100% of nominal unit airflow. The EA damper assembly has a factory-installed, foldable rain hood permanently attached to the cabinet to prevent windblown precipitation from entering the unit. The rain hood is rotated into the cabinet and secured for shipment so that upon installation, they can be rotated upwards and screwed into place.

OA inlet openings are covered by a factory-installed foldable rain hood permanently attached to the cabinet to prevent windblown precipitation from entering the unit. The rain hoods on the left and right sides of the unit are rotated into the cabinet and secured for shipment so that upon installation they can be rotated upwards and screwed into place. The OA hood contains a removable and cleanable filter with an efficiency rating of 50% based on ASHRAE 52-76. Damper blades are fabricated from a minimum of 16-gauge galvanized steel. Damper shafts are fabricated from solid steel and mounted in the frame with bronze bearings.

### **Economizer ultra low leakage dampers [optional]**

- Damper assemblies are ultra low leak design. Damper blades are fabricated from a minimum of 16-gauge galvanized steel. Blade edges are covered with vinyl seals. Damper assemblies have a maximum leakage rate of 4 CFM/sq. ft at 1.0 in. of water gauge (iwg) when tested in accordance with AMCA Standard 500, and have a longevity of 60,000 damper opening and closing cycles. The unit provided economizer meets the damper leakage and life cycle requirements for ASHRAE 90.1-2019, 2018 International Energy Conservation Code® (IECC), and 2016 California Title 24 standards.

### **Outside airflow measurement [optional] -**

Fresh air is introduced into the unit via an outside airflow measurement station for full airflow measurement from 0–100% outside airflow. The airflow measurement station is designed into the unit and includes all controls, dampers, and components to monitor airflow accurately.

### **Economizer with fault detection and diagnostics (FDD) -**

Economizer with FDD is provided when economizer is selected. As required per ASHRAE 90.1-2019 and California Title 24, FDD system provides alarms for:

- Damper not modulating.
- Economizer not available for suitable outside air conditions.
- Economizer available for unfavorable outside air conditions.
- Excess outside air.
- Temperature sensor failure and fault.

## **ERW [optional]**

1. ERW performance is AHRI 1060 certified and bears the AHRI certified label. Components that are independently tested or rated in accordance with are not acceptable. Manufacturer membership in AHRI is not an acceptable substitute. Certified components must be listed as active in the AHRI directory, see <http://www.ahridirectory.org>.
2. The energy recovery cassette is a UL recognized component for fire and electrical safety and bear the UR mark. recognized components are listed in the UL directory, see <http://database.ul.com>.
3. The energy recovery cassette complies with NFPA 90A standard by virtue of UL 1812 and UL 900 standards for fire tests to determine flammability and smoke density.
4. The energy recovery cassette incorporates a rotary wheel in an insulated cassette frame complete with removable energy transfer media, seals, drive motor, and drive belt. Cassette frame and structural components are constructed of G90 galvanized steel for corrosion resistance.
5. Wheel structure consists of a welded hub, spoke, and continuous rolled rim assembly of stainless steel, and is self-supporting without energy transfer segments present. Wheel structure is connected to the shaft by means of taper lock bushings.
6. Wheel bearings are permanently sealed and selected for a minimum 30 year L10 life of 400,000 hours. Bearings requiring external grease fittings or periodic maintenance are not acceptable.
7. Energy transfer media is constructed of a durable synthetic lightweight polymer. Media is wound continuously with one flat and one structural layer in an ideal parallel plate geometry. Airflow across heat exchanger surface remains laminar. Energy transfer media does not exceed 3 inches in depth. Energy transfer media is suitable for use in corrosive, marine, or coastal environments without the need for additional coatings. Energy transfer media is capable of repeated washings without significant degradation of the desiccant bond as documented by an independent third party.
8. Desiccant is either silica gel or molecular sieve and permanently bonded to the energy transfer media without the use of binders or adhesives, which may degrade desiccant performance. Desiccants not permanently bonded are not acceptable due to potential delamination or erosion of the desiccant from the energy transfer media. Desiccant is non-migrating nor does it dissolve or deliquesce in the presence of water or high humidity.
9. Wheels are provided with removable energy transfer segments. The unit is designed to facilitate side serviceable ERW. Side service allows for all ERW segments to be pulled for removal. Segments are removable without the use of tools to facilitate maintenance and cleaning. Energy recovery segments are cleanable outside of the cabinet with detergent or alkaline coil cleaner and water. Energy transfer segments are capable of submersion in a cleaning solution. Submersion is capable of restoring latent performance to within AHRI certified performance limits.

10. All diameter and perimeter seals are provided as part of the cassette assembly and are factory set. Seals are non-contact nylon pile brush seal oriented in a labyrinth style configuration. Diameter seals are fully adjustable and easily accessible. Perimeter seals are permanently mounted to the wheel rim and not require adjustment. Seals that mount to the frame are not acceptable.
  11. The wheel drive motor is a UL recognized component and is mounted in the cassette frame and supplied with a service connector or junction box. Three-phase motors are suitable for use in both standard and inverter rated applications.
  12. The unit has 2 in. MERV 8 replaceable filters for the outside air and exhaust air to help keep the wheel clean and reduce maintenance. The ERW is energized briefly for cleaning and blocking protection if it has not been operated for extended periods.
  13. The ERW has a bypass damper. The bypass damper has two positions, ON or OFF, according to the heating or cooling demand.
  14. The rooftop unit provides frost protection for the ERW. The controller varies the speed of the wheel, by starting and stopping, to prevent frost condition.
4. **Powered exhaust with VFD** - A DWDI forward-curved centrifugal exhaust fan is provided to exhaust building return air to relieve building static pressure. Exhaust airflow is modulated via a factory-installed and commissioned VFD with the same nameplate horsepower as the exhaust fan motor. An access door is provided on at least one side of the unit for fan and motor access.
  5. **Dual powered exhaust with VFD (60 ton to 80 ton cabinets with ERW)** - Dual DWDI forward-curved centrifugal exhaust fans provided to exhaust building return air to relieve building static pressure. Exhaust airflow is modulated via a VFD that is provided for each exhaust fan. The VFD driven exhaust fan has a factory-installed and commissioned VFD with the same nameplate horsepower as the exhaust fan motor. An access door is provided on at least one side of the unit for fan or motor access.
  6. **Power return fan with VFD and exhaust** - A SWSI plenum fan is provided to draw return air from the building to the rooftop unit. [(60 ton to 80 ton) plenum fan is direct drive.] An access door is provided on at least one side of the unit for fan and motor access. The return fan operates to maintain a constant pressure within the RA plenum. An EA damper is provided to modulate building exhaust. The damper is controlled via building pressure. The RA damper and OA damper independently modulate volumes of return and outside airflows.
  7. **Exhaust fan VFD manual bypass [optional with single exhaust fan configurations]** - A two contactor manual bypass is provided to permit fan operation in the event of a fan failure.
  8. **Return fan VFD manual bypass [optional 25 ton to 50 ton]** - A two contactor manual bypass is provided to permit fan operation in the event of a fan failure.
  9. **Redundant VFD [optional 60 ton to 80 ton]** - Direct drive plenum (DDP) return fans are provided with a 100% redundant VFD. Redundant VFD automatically operates in the event that the primary VFD fails.
  10. **Return [exhaust] fan VFD reactor [optional]** - A 3% impedance AC line reactor is provided for return [exhaust] fan VFD.
  11. **Airflow measurement station [optional]** - Installed on the return fan. Return fan airflow is viewable on the control panel and able to be communicated across the Building Automation System (BAS).
  12. **Belt guards [optional on belt driven fans]** - These are provided to enclose the drive and sheave package on return [exhaust] fan.
  13. All VFDs are factory tested and matched with each unit.

## Building pressure control

- ① **Note:** Select one of the following types of building pressure control.
1. **No building exhaust or relief** - The unit has no provisions to exhaust building return air.
  2. **Barometric relief damper** - Building air exhaust is accomplished through barometric relief dampers installed in the return air (RA) plenum. The dampers open relative to the building pressure. The opening pressure is adjustable.
  3. **Powered exhaust with modulating DA damper** - A double width, double inlet (DWDI) forward-curved centrifugal exhaust fan is provided to exhaust building return air to relieve building static pressure. The fans operate at a constant volume and based on building static pressure. Exhaust airflow is modulated via a parallel-acting control damper. The EA dampers are sized for 100% of the exhaust airflow. An access door is provided on at least one side of the unit for fan and motor access.

For powered exhaust or return fan options above, use the following:

1. **Exhaust or return fan motor** - Fan motors are National Electrical Manufacturers Association (NEMA) design ball-bearing types with electrical characteristics and horsepower as specified. [Shaft grounding rings on motors are provided to prevent electrical bearing fluting damage by safely diverting harmful shaft voltages and bearing currents to ground, increasing the motor longevity.] Motors are nominal 1,800 RPM [or 1,200 RPM ], open drip-proof (ODP) type [total enclosed fan-cooled (TEFC) type]. The motor is located within the unit on an adjustable base.
2. **Mountings** - Fan and fan motor are internally mounted and isolated on a full width isolator support channel using 1 in. [2 in.] springs [and seismic restraint]. The fan is connected to the fan cabinet using a flexible connection to insure vibration-free operation.
3. **Bearings and drives [option on belt driven fans]** - Fan bearings are self-aligning, pillow block, or flanged type regreaseable ball bearings and are designed for an average life L50 of at least 200,000 hours. All bearings are factory lubricated and equipped with standard hydraulic grease fittings [and lube lines extended to the motor side of the fan]. Fan drives are selected for a 1.5 service factor and anti-static belts are furnished. [Optional spare belts are shipped loose from the factory.] All drives are fixed pitch. Fan shafts are selected to operate well below the first critical speed and each shaft is factory coated after assembly with an anti-corrosion coating.

## Air blender [optional]

1. Multiple-blade, air-mixer assembly mix air to prevent stratification.
2. Air blenders have a rotary turbulating design consisting of radially extending blades. Units are completely fixed devices with no moving parts.
3. Static air mixers material are 0.080 in., 5052 H34 alloy aluminum. Static air mixers are welded.
4. Simple mixing devices that do not produce expanding discharge with counter rotational mixing are not acceptable.

## Filter section

### Draw-through filters

- ① **Note:** Select a filter rack, filter media, and transducer if desired.
1. **Angled filter rack** - 2 in. filters are provided by others [2 in. throwaway filters are provided in an angled filter rack] [2 in. (MERV 8) pleated filters are provided in an angled filter rack]. Filter efficiencies are rated in accordance with ASHRAE Standard 52.2. All filter holding frames consist of heavy duty galvanized steel designed for industrial applications. All filters are side accessible with access doors provided on both sides of the filter section.
  2. **Rigid filter rack** - 2 in. and 12 in. filters are provided by others [12 in. (MERV 14) rigid filters with 2 in. (MERV 8) pleated pre-filters are provided] [18 in. (MERV 15) bag filters with 2 in. (MERV 8) pleated pre-filters are provided]. Filter efficiencies are rated in accordance with ASHRAE Standard 52.2. All filter holding frames consist of heavy duty galvanized steel designed for industrial applications. All filters are side accessible with access doors provided on both sides of the filter section.
  3. **Vertical filter rack** - 4 in. filters are provided by others. [4 in. (MERV 8) pleated filters are provided.] Filter efficiencies are rated in accordance with ASHRAE Standard 52.2. All filter holding frames consist of heavy duty galvanized steel designed for industrial applications. All filters are side accessible with access doors provided on both sides of the filter section.
  4. **Filter transducer** - A filter transducer is provided and wired to the rooftop's control panel. The unit controller displays the pressure drop across the filter[s]. A single transducer is provided to measure pressure drop across both filter banks. [Transducers are provided to measure pressure drop across each filter bank.]
  5. **Differential pressure gauge** - A flush mounted, factory-installed differential pressure gauge is provided to measure pressure drop across both filter banks. [Flush mounted, factory-installed differential pressure gauges are provided to measure pressure drops across each filter bank.] The manufacturer provides fully functional gauges complete with tubing.

## Final filters

- ① **Note:** Select a filter rack, filter media, and transducer if wanted.
1. **Rigid filter rack** - 2 in. and 12 in. filters are provided by others [12 in. (MERV 14) rigid filters with 2 in. (MERV 8) pleated pre-filters] [18 in. (MERV 15) bag filters with 2 in. (MERV 8) pleated pre-filters are provided]. Filter efficiencies are rated in accordance with ASHRAE Standard 52.2. All filter holding frames consist of heavy duty galvanized steel designed for industrial applications. All filters are side accessible with access doors provided on both sides of the filter section.
  2. **High efficiency particulate air (HEPA) filter rack** - 2 in. and 12 in. filters are provided by others [12 in. (MERV 17) HEPA filters with 2 in. (MERV 8) pleated pre-filters are provided]. Filter efficiencies are rated in accordance with ASHRAE Standard 52.2. All filter holding frames consist of heavy duty galvanized steel designed for industrial applications. All filters are front loading with access doors provided on both sides of the filter section.
  3. **Filter transducer** - A filter transducer is provided and wired to the rooftop's control panel. The unit controller displays the pressure drop across the filter[s]. A single transducer is provided to measure pressure drop across both filter banks. [Transducers are provided to measure pressure drop across each filter bank.]
  4. **Differential pressure gauge** - A flush mounted, factory-installed differential pressure gauge is provided to measure pressure drop across both filter banks. [Flush mounted, factory-installed differential pressure gauges are provided to measure pressure drops across each filter bank.] The manufacturer provides fully functional gauges complete with tubing.

## Evaporator section

1. **Cooling coil** - Evaporator coils are a direct expansion type with interlaced circuiting to assure complete coil face activity during part-load operation. Coil tubes are copper with internally enhanced tubes. Tubes are enhanced mechanically and expanded to bond with the aluminum [copper fins]. All coils are pressure-tested at a minimum of 450 psig. [Evaporator coils are protected by the E-Coat 10-1 four coat process. Coils are dipped in a phenolic coating, that provides substantial resistance to corrosion of aluminum and copper. E-Coat coils are rated to exceed 6000 hours salt spray in accordance with ASTM B117 / DIN 53167.]

2. **IAQ drain pan** - The main coil drain pan is double-sloped with a condensate connection through the base rail of the unit. Drain pans for cooling coils [and humidifier] meet the requirements of ASHRAE 62.1. Drain pans are constructed of stainless steel. [Provide a condensate overflow switch in the primary drain pan.]
3. **Intermediate drain pan 40 ton to 80 ton** - Coils with finned height greater than 48 in. have an intermediate drain pan extending the entire finned length of the coil. The intermediate pans have drop tubes to guide condensate to the main drain pan.
4. **UV lights [optional]** - UVC lights provide fly-by virus deactivation and surface decontamination of the coil and drain pan. The UV lights are installed in the downstream side of the evaporator coil or drain pan. UVC lights provide a minimum of 1500 µJ/cm<sup>2</sup>. UVC lights have a minimum 9,000 hours of service. The UV lights, tubes, are shipped loose in protective packaging for installation by the contractor.

## Supply fan section

1. **Fan** - The fan section is equipped with a SWSI airfoil plenum wheel. Plenum fan is direct drive. An access door is provided on the opposite side of the control panel for fan/motor access. [60 ton to 80 ton – the fan section is equipped with dual SWSI airfoil plenum wheels. Plenum fans are direct drive. [Dual SWSI supply fans are connected to a single VFD.] An access door is provided on the opposite side of the control panel for fan/motor access.]
2. **Fan motor** - Fan motors are NEMA design ball-bearing types with electrical characteristics and horsepower as specified. Motors are nominal 1,800 RPM, ODP type [TEFC type].
3. **Mountings** - Fan and fan motor are internally mounted and isolated on a full width isolator support channel using 1 in. [2 in.] springs [and seismic restraint].
4. **Variable air volume (VAV) fan control** - VAV supply fan control is accomplished by using [a] VFD[s] and supply fan motor combination matched with supply fan to generate design performance at appropriate fan speed. The VFD[s] includes an integral DC line reactor to reduce harmonic distortion in the incoming and outgoing power feeds. If a DC line reactor is not provided, an AC line reactor[s] is provided.

5. **Single zone VAV (SZVAV)** - In cooling mode, refrigeration capacity or compressor stages are cycled ON or OFF to maintain DA temperature (DAT). In heating mode, additional stages are cycled ON or modulated to maintain DAT setpoint. The supply fan speed is modulated to maintain zone temperature setpoint. The unit uses either a BAS signal, RA temperature (RAT), or a zone temperature sensor to determine zone temperature and deviation from setpoint.
  6. **Redundant VFD [optional 25 ton to 50 ton]** - A direct drive plenum (DDP) supply fan is provided with a 100% redundant VFD. A redundant VFD automatically operates in the event that the primary VFD fails.
  7. **Redundant VFD - optional 60 ton to 80 ton** - Dual DDP supply fans are provided with dual VFDs. [VFDs are supplied to independently operate the two supply fan motors.]
  8. All VFDs are factory tested and matched with each unit.
  9. **VFD reactor [optional]** - A 3% impedance AC line reactor is provided for the supply fan VFD[s].
  10. **Shaft grounding rings [optional]** - on motors are provided to prevent electrical bearing fluting damage by safely diverting harmful shaft voltages and bearing currents to ground, increasing the motor longevity.
  11. **Inlet guards [optional]** - are provided on inlet of supply fan.
  12. **Supply airflow measurement [optional]** - capability is provided. Supply fan airflow is viewable on the control panel and readable across the BAS.
2. **Burner and ignition controls** - The burner includes a direct-driven induced-draft combustion fan with energy efficient direct spark ignition, redundant main gas valves with pressure regulator.
  3. **Combustion air fan** - The inducer fan[s] maintains a positive flow of air through each tube to expel the flue gas and to maintain a negative pressure within the heat exchanger relative to the conditioned space.
  4. **Safety devices** - A high limit controller with automatic reset to prevent the heat exchanger from operating at an excessive temperature is included. A centrifugal switch on the induced draft fan motor shaft prevents ignition until sufficient airflow is established through the heat exchanger. A rollout switch provides secondary airflow safety protection. The rollout switch discontinues furnace operation if the flue becomes restricted.
  5. **Flue** - The furnace flue is shipped loose to protect it from damage during transit. The flue is field-mounted by the installing contractor. The flue outlet is located above the unit to help prevent recycling of combustion gases back through the heat exchanger.
  6. **Agency certification** - Gas heating units are designed in conformance with ANSI Z83.8-2016/ CSA 2.6-2016 standards and carry a CSA listing. All gas heating units have 81% steady state efficiency rated in accordance to 2023 Department of Energy Efficiency code. All gas heating units meet the requirement of AHRI CFRN Certification program and Code of Federal Regulations, 10 CFR Part 43, which references efficiency testing method in standard ANSI Z21.47.
  7. **Valves** - A factory provided gas heater isolation valve is shipped loose for installation in the field by others. Punched holes are provided in the bottom [side] of the unit. The holes are capped for field to make suitable connection. A bottom [side] penetration option is provided with piping to extend out of the unit.

## Discharge air plenum

- ① **Note:** Select one of the following heat or no heat configurations.

### Cooling only

The DAT sensor is located in the DA plenum, such that it accurately measures the DAT.

### Staged gas heat

The heating section includes an induced draft furnace in two [four] [six] stages of heating capacity. [Optional high altitude kit is shipped loose from the factory.] [Optional liquid propane (LP) conversion kit is shipped loose from the factory.]

1. **Heat exchanger** - The heat exchanger is constructed of tubular aluminized steel [stainless steel] and flue assembly.

### Modulating gas heat

For applications requiring gas heat for morning warm-up, supply air (SA) tempering, or other heating needs, a modulating natural gas furnace is available for finer temperature control. The furnace is located in the DA plenum, downstream of the supply fan. The DAT sensor is located across the face of the supply duct opening in the unit. [Optional high altitude kit is shipped loose from the factory.]

[Optional LP conversion kit is shipped loose from the factory.]

1. **Heat exchanger** - The heat exchanger is constructed of tubular stainless steel and flue assembly.
2. **Burner and ignition controls** - The burner includes a direct-driven induced-draft combustion fan with energy efficient direct spark ignition, redundant main gas valves with pressure regulator.
3. **Combustion air fan** - The inducer fan[s] maintains a positive flow of air through each tube to expel the flue gas and to maintain a negative pressure within the heat exchanger relative to the conditioned space.
4. **Safety devices** - A high limit controller with automatic reset to prevent the heat exchanger from operating at an excessive temperature is included. A centrifugal switch on the induced draft fan motor shaft prevents ignition until sufficient airflow is established through the heat exchanger. A rollout switch provides secondary airflow safety protection. The rollout switch discontinues furnace operation if the flue becomes restricted.
5. **Flue** - The furnace flue is shipped loose to protect it from damage during transit. The flue is field-mounted by the installing contractor. The flue outlet is located above the unit to help prevent recycling of combustion gases back through the heat exchanger.
6. **Agency certification** - Gas heating units are designed in conformance with ANSI Z83.8-2016/CSA 2.6-2016 standards and carry a CSA listing. All gas heating units have 81% steady state efficiency rated in accordance to 2023 Department of Energy Efficiency code. All gas heating units meet the requirement of AHRI CFRN Certification Program and Code of Federal Regulations, 10 CFR Part 431, which references efficiency testing method in standard ANSI Z21.47.
7. **Valves** - A factory provided gas heater isolation valve is shipped loose for installation in the field by others. Punched holes are provided in the bottom [side] of the unit. The holes are capped for field to make suitable connection. A bottom [side] penetration option is provided with piping to extend out of the unit.

## Electric heat

An electric slip-in heater is installed within the rooftop unit DA plenum to provide the heating requirements per the schedule shown on the plans. The electric heater is wired in such a manner as to provide three [four] [six] [eight] [ten] steps of

capacity control. Heating element branch circuits are individually fused to maximum of 48 Amps per National Electrical Code (NEC) requirements. Unit are provided with staged [modulating 0 VDC to 10 VDC silicon controlled rectifier (SCR)] electric heat.

1. **Heat element** - The heating element is an industrial grade design using an open coil made of the highest grade resistance wire containing 80% nickel and 20% chromium. The resistance coils are adequately supported in the air stream using ceramic bushings in the supporting framework. Terminals of the coil are stainless steel with high temperature ceramic bushings.
2. **Safety devices** - The primary high temperature protection is an auto reset type thermal cut out. Secondary protection is provided by a manual reset type thermal cut out.
3. **Agency certification** - The operation of the electric heater is an integral part of the rooftop's control system. Power connection to the heater is through the power panel of the unit. Electric heat is tested and certified in accordance with UL 60335-2-40.

## Hot water heat

A hot water coil is installed in the rooftop DA plenum.

1. **Construction** - The hot water coil has one [two] row[s]. Primary surface is 1/2 in. OD copper tube, staggered in direction of airflow. Connections have 1/4 in. FPT drain plug on each connection. A structural galvanized steel casing protects the coil. The coil is circuited to provide free draining and venting through one vent and drain. Freezestat is provided to prevent coil freeze up. Access doors are provided for convenient access to the valve for maintenance and inspection.
2. **Testing** - Completed coil including headers, connections, and return bends are tested with 325 pounds compressed air under water. Coils are designed for operation at 250 psig design working pressure.
3. **Valves** - Factory [field] provides three-way modulating control valve and spring return valve actuator capable of receiving 0-10 VDC signal. The valve actuator is controlled by factory-installed main unit controller. [Field-provided valve matches specifications/ratings as recommended by unit manufacturer.] Unit have hole markings for field to drill holes through the base or side of the unit.

## Steam heat

A steam heating coil is installed in the rooftop DA plenum.

1. **Construction** - The steam coil is constructed in the non-freeze style. The steam coil has one row. Tubes are 1 in. OD seamless copper tubing with a minimum wall thickness of 0.035 in. and expanded into the fin collars for maximum fin-tube bond. Inner distributing tubes are 5/8 in. OD seamless copper tubing with a minimum wall thickness of 1/4 in.. All header connections consist of red brass, with male pipe threads and silver braze to headers. Casing is galvanized steel. The core is pitched in the direction of the condensate connection for proper drainage. Freezestat is provided to prevent coil freeze up. Access doors are provided for convenient access to the valve for maintenance and inspection.
  2. **Testing** - The completed coil, including headers and connections, are tested underwater with 325 pounds compressed air to ensure a leak-free coil.
  3. **Valves** - Factory [field] provides two-way modulating control valve and non-spring return valve actuator capable of receiving 0–10 VDC signal. Steam valve is designed for operation at 2 psig minimum and 15 psig maximum steam pressure. Valve actuator is controlled by factory-installed main unit controller. [Field provided valve must match specifications and ratings as recommended by the unit manufacturer.] The unit has hole markings for field to drill holes through the base or side of the unit.
5. Distribution tubes include threaded standoffs for trouble free attachment to factory-supplied support bracket.
  6. All steam tubes are 304 stainless steel construction. 409 stainless steel header and distribution tubes are not acceptable.
  7. Stainless steel nozzle inserts ensure condensate free steam is discharged from the center of the distribution tubes. Systems without nozzle inserts, or other than stainless steel, are not acceptable.
  8. Stainless steel nozzle inserts have metered orifices, sized to provide even distribution of the discharged steam, spaced for optimum steam absorption.
  9. The header functions as an internal steam separator, therefore an external steam separator is not required.
  10. Manufacturer provides adjustable 304 stainless steel mounting frame.
  11. Tubes and headers accommodate field retrofit of insulation for increased energy efficiency.

### Shipped loose items

1. The manufacturer provides steam control valve with electrical actuator normally closed, spring return (24 V), steam control valve with equal percent flow characteristics and positive shut off against steam. The control valve is compliant with EN 13547 standard and ANSI B1.20.1 (NPT) end connection standard. The temperature rating is compliant with ANSI 16.104/FCI 70.2 and for control shut off leakage ANSI/ISA-75.11 flow characteristics standards. The steam control valve has a brass forged body with stainless steel ball and stem assembly.
2. The manufacturer provides cast iron steam traps and iron wye strainer

## Humidifier [optional]

### Humidifier steam manifold and dispersion panel

- Short absorption manifold is designed to distribute pressurized steam from a facility steam boiler, to directly inject the steam into air for humidification.

1. Absorption distance characteristic prevents water accumulation on duct surfaces beyond 12 in. downstream of the steam dispersion panel.
2. Steam dispersion panel consisting of a (one) horizontal 304 stainless steel round header supplying steam to a bank of closely spaced [12 in. for 25 ton to 50 ton, 6 in. for 60 ton, 3 in. for 70 ton to 80 ton] vertical tubes, as necessary to meet absorption distance requirements, and to reduce condensation losses.
3. Steam inlet and condensate return are located on the same side and at the bottom of the header to allow single point entry and floor mounting.
4. Vertical stainless steel distribution tubes provide condensate evacuation. Horizontal distributor tubes are not acceptable.

### Sound attenuator [optional]

1. Sound attenuator, or silencer, segments are provided as shown on drawings. Silencers are rectangular, [24 in. for 25 ton to 50 ton, 36 in. for 60 ton to 80 ton] long sound attenuators as indicated on drawings and equipment schedule.
2. Outer casings of rectangular silencers are made of 22 gauge type G60 galvanized steel.
3. Interior partitions for rectangular silencers are not less than 26 gauge type G60 galvanized perforated steel.
4. The filler material is inorganic glass fiber of a proper density to obtain the specified acoustic performance and is packed under not less than 5% compression to eliminate voids due to vibration and settling. The material is inert, vermin-proof, and moisture-proof.

## Condenser section

1. **Condenser fans** - Condenser fans are matched up with compressors to optimize system control. Condenser fans are propeller type with aluminum blades, directly driven by permanently lubricated three-phase motor.
2. **Condenser coil** - Microchannel condenser coils are constructed of parallel flow aluminum alloy tubes metallurgically brazed to enhanced aluminum alloy fins. Condenser cleaning hatches are provided for access to condenser coil without the removal of condenser fans. [Condenser coils are protected by the E-Coat 10-1 four coat process. Coils are dipped in a phenolic coating, that provides substantial resistance to corrosion of aluminum.] E-Coat coils are rated to exceed 6000 hours salt spray in accordance with ASTM B117 / DIN 53167.
3. **Low ambient [optional]** - Compressors operate down to -10.0°F and resume cooling at -7.0°F by monitoring the refrigeration system liquid line pressure and adjusting condenser airflow to maintain the proper liquid line pressure to protect unit operation. Airflow adjustment occurs through a combination of VFD driven condenser fans and fan cycling. Liquid line pressure transducers are included to provide the pressure information on the unit control display.
4. **Shut-off valves [optional]** - Discharge and suction [and liquid] shut-off valves are included to provide a means of isolating the refrigerant charge in the system so that the refrigeration system is serviced without removing the charge in the unit.
5. **Sight glasses** - are accessible without having to open air handler section access doors or remove panels.
6. **Fixed speed compressors** - Units use hermetic scroll compressors, piped and charged with oil and R-410A refrigerant. Each compressor is protected from over-temperature and over-current conditions. Compressors are vibration-isolated from the unit, and installed in an easily accessible area of the unit. All compressor-to-pipe connections are brazed to minimize potential for leaks. Units are designed to minimize leaving air temperature changes when varying capacity. Steps of capacity control do not exceed 23% of unit capacity when modulating from minimum to maximum. Hot gas bypass operation are not used to meet maximum modulation steps of control. Variable speed drive compressors are used if unit is not capable of meeting the maximum modulation percentage of step capacity.
7. **Variable speed drive compressors [optional]** - Units use variable speed drive scroll compressor, piped and charged with oil and R-410A refrigerant. Units have a minimum capacity of 15% of full load. Each compressor is protected from over-temperature and over-current conditions. Compressors are vibration-isolated from the unit and installed in an easily accessible area of the unit. All compressor-to-pipe connections are brazed to minimize potential for leaks. Variable speed drive scroll compressors are matched and factory tested with VFD. All high efficiency units meet 2019 Consortium of Energy Efficiency (CEE) highest tier efficiency ratings.
8. **Modulating hot gas reheat (HGRH) [optional]** - Modulating hot gas reheat (HGRH) is provided. The unit includes a three-way stepper motor driven modulating valve and controller, a HGRH coil mounted downstream of evaporator coil, and all associated refrigerant piping. The unit controller modulates the three-way HGRH valve to control the amount of compressor discharge gas to the HGRH coil. [HGRH coils are protected by the E-Coat 10-1 four coat process. Coils are dipped in a phenolic coating that provides substantial resistance to corrosion of aluminum.]
9. **In-line refrigerant filter driers - replaceable core filter driers** - Liquid line filter driers are provided as a standard on the unit. [The replaceable core filter drier on the unit provides a convenient means for maintaining and optimizing the unit's refrigeration system.]
10. **Compressor sound treatment [optional]** - Compressor sound blankets with heat shield are provided to attenuate radiated sound from the compressors.
11. **Condenser enclosure [optional]** - The condenser section is enclosed by a wire grill [louvered] condenser enclosure on the three exposed sides. Paint finish matches the color and salt spray specifications of the unit exterior.
12. **Condenser enclosure [optional]** - The condenser section is enclosed by a louvered hail guard on the end of the unit. Paint finish on the louvered hail guard matches the color and salt spray specifications of the unit exterior. The unit is enclosed by a wire grill on the other two sides.

## Controls

1. **Enclosure** - The unit is factory configured, installed, wired, and tested with a rooftop unit controller housed in a rain and dust-tight, powder painted, steel cabinet behind hinged, latched, and gasket-sealed door. VFD control keypads are located in the control cabinet for accessibility and servicing while the unit is operating.
2. **115 V convenience outlet [optional]** - A duplex ground fault circuit interrupt (GFCI) receptacle is factory-mounted in a weatherproof enclosure and wired for a 15 amp load. Electrical power is de-energized to the convenience outlet when the optional unit mounted disconnect has been turned OFF. Unit powered convenience outlet includes transformer to step down to 115 V.
3. **Basic controls** - Control includes automatic start, stop, operating, and protection sequences across the range of scheduled conditions and transients. The rooftop unit controller provides automatic control of compressor start/stop, energy saver delay and anti-recycle timers, condenser fans, and unit alarms. Automatic reset to normal operation after power failure. Software and user programmed setpoints are stored in nonvolatile memory for the 20-year expected life of the microprocessor. The real time clock (RTC) information is retained for a minimum of 72 hours during power loss with a super capacitor-backed circuit.
4. **Smart equipment control** - The unit is supplied with the Smart Equipment control system. All units are factory commissioned, configured, and run tested.
5. **Standard display** - The display is organic light-emitting diode (OLED) with green characters on black background providing high visibility. The display provides a minimum of 175 characters in total with 35 characters × 5 lines. The OLED display is a 256 × 64 dot matrix. The display shows animated text, symbols, and descriptions down to -40.0°F (-40.0°C) without noticeable degradation of contrast or display response time. Numeric data is provided in imperial or metric units. A sealed, membrane style keypad with 20 keys is used to navigate the unit controller and enter data. Specific keys are individually assigned to allow quick selections. The software on the user interface (UI) is upgradable in the field.
6. **Touchscreen display** - The display is a 10 in. WXGA type color wide screen, thin film transistor (TFT) with multi-touch capacitive touchscreen and 1280 × 800 resolution. The screen details all operations and parameters, using an interactive graphical representation of the rooftop unit and its major components. The display does not require a laptop or mobile display to access complete functionality. The display is able to integrate with multiple controllers connected on a common BACnet MS/TP communication bus. The display shows animated text, symbols, and descriptions down to -4.0°F (-20.0°C) without noticeable degradation of contrast or display response time. Numeric data is provided in imperial or metric units. Specific icons are individually assigned to allow quick selections. The software on the UI is upgradable in the field.
7. The following display information is available based on selected unit options:
  - a. Unit summary with serial, model number, language, unit status, and enable. Controller hardware, firmware, and network inputs.
  - b. Sensor information for all devices connected to the unit and setpoints.
  - c. Commissioning menu has options to view key parameters such as occupancy, cooling, heating, economizer, ERW, morning warm-up, staggered start, safety setup, low ambient and demand control ventilation (DCV).
  - d. Start-up, air balancing and commissioning wizards are provided for field technicians to complete unit configuration and start-up.
  - e. Occupied, unoccupied, coast modes.
  - f. Date, time, time zone, schedules.
  - g. Cooling enable, status, setpoints, stages, compressor capacity, runtime, anti-short cycle time, rapid start, and morning cool down.
  - h. Heating mode, enable, status, stages, capacity, runtime, setpoints, valve commands, and morning warm-up.
  - i. Supply fan, return/exhaust fan status, command, air proving switch, VFD speed, runtime, and faults.
  - j. Condenser fan staged and modulating command, low ambient.
  - k. Economizer mode, damper position, airflow, fresh air, and alarms for economizer FDD.
  - l. HGRH status, enable, humidification setpoint, and valve command.
  - m. Energy recovery wheel status, command, output, temperature.

- n. Smoke control modes, sensor inputs, smoke detector shutdown.
  - o. Unit alarms such as safety switch, phase monitor, compressor safety, filter differential pressure, carbon dioxide (CO<sub>2</sub>), low pressure, high pressure, freeze stat, UV light, and condensate switch. Alarms mode with up to 5 current alarms and 25 previous alarms with time and date.
8. **Adjustable height display interface** - The display interface has up to three different installation height locations within the panel. The display interface is installed on a hinge with a magnetic catch to allow wiring and electronics behind the display to be easily accessed.
  9. **Diagnostics** - Upon start-up of the unit controller, the unit controller runs through a self-diagnostic check to verify proper operation and sequence loading. The rooftop unit controller continually monitors all input and output points to maintain proper operation. The unit continues to operate in a trouble mode or shut down as necessary to prevent an unsafe condition for the building occupants or to prevent damage to the equipment. In the event of a unit shutdown or alarm, the operating conditions, date, and time are stored in the shutdown history to facilitate service and troubleshooting. A minimum of 10 error histories are recorded.
  10. **Compressor capacity modulation** - Staging of the multiple fixed [fixed and variable] speed compressors is used to control refrigeration capacity. Upon entering cooling mode from other modes, the unit controller estimates the cooling requirement and match it closely to the capacity in order to reduce the time required to satisfy the cooling requirements. After the initial calculation, the unit controller adds or reduces stage as necessary to establish a balance between the unit capacity and the space cooling load.
  11. **Demand control ventilation (DCV) [optional]** - CO<sub>2</sub> sensors are connected to the unit. The unit controller resets the minimum OA damper position based on demand. DCV remains active as long as the unit is in occupied mode. The unit controller has built-in sequences for indoor CO<sub>2</sub> and comparative CO<sub>2</sub>.
  12. **Smoke detector [optional]** - The supply [return] [supply and return] smoke detector[s] are provided with the unit. A smoke detector ON signal shuts down the unit.
  13. **Safety inputs** - The smoke control sequences is available through BAS communication [and hard wired connections using the Customer Terminal board]. The smoke control sequences are used whenever the smoke control binary inputs are turned ON to remove, exhaust, or ventilate smoke, fumes, or other airborne contaminants from the occupied space. The unit controller includes purge, pressurization, and evacuation sequences of operation. Smoke control inputs are assigned a higher priority over smoke detector and override a smoke detector shutdown.
  14. **Twinning** - enables control of multiple rooftop units sharing a common supply duct. The control algorithm provides independent logic unit control. The independent logic unit control system does not require switchover of primary logic in case of rooftop unit failure. The unit provides quick response time, shared data for sensors and setpoints, simple configuration, and easy setup. Twinning configuration is available through BACnet®. No additional control or communication wiring is required.
  15. The control is installed and tested at the factory where the equipment is assembled. The following controls features are available based on selected unit options:
    - a. The control uses a wall sensor that has a means of overriding the unoccupied mode for a programmable amount of time.
    - b. The unoccupied override time is programmed in minutes up to 4 hours.
    - c. The control has a SA sensor as standard.
    - d. The control has a RA sensor as standard.
    - e. The control has an outside air temperature (OAT) sensor as standard.
    - f. The control uses the RA sensor in place of the space sensor if the space sensor fails for any reason.
    - g. The control has a 365 day real time clock (RTC).
    - h. The control has an occupancy schedule that allows two different occupied schedules per day for each of the seven days of the week individually.
    - i. The control has 20 holiday schedules, each capable of 99 days. The control's holiday schedules has a start time associated with each schedule.
    - j. The control is capable of operating the economizer using dry bulb, single enthalpy, or dual enthalpy.
    - k. The control has the ability to do demand ventilation control using two CO<sub>2</sub> sensors.

- l. The control has a programmable maximum OA damper position for IAQ operation.
- m. The control has the ability to temper the ventilation air during times when heating or cooling is not required.
- n. The control must be able to lock out cooling below a programmable OAT setpoint.
- o. The control is able to lock out heating above a programmable OAT setpoint.
- p. The control is able to do a pre-occupancy purge.
- q. The control has purge, de-pressurization, and pressurization sequence for smoke control.
- r. The control has the ability to read pressure across two filter banks.
- s. The control has the capability of reading a fan proving switch.
- t. The control has an intelligent recovery function that brings the space to the occupied setpoint just before or at the beginning of the first occupied schedule each day. The control learns and applies the minimum runtime required to heat or cool the space to setpoint for the first occupied period of a day. The unit controller is capable of compensating start time based on OAT.
- u. The control satisfies cooling demand using unequal compressor staging combinations.
- v. The control has the ability to enable the ERW.
- w. The control monitors the outside airflow.
- x. The control provides a low ambient cooling operation.
- y. The control enables either dehumidification, humidification, or temperature cool-only mode based on humidity setpoint.
- z. The control has compressor safety monitoring.
- aa. The control has FDD alarm monitoring for economizer operation.
- ab. The control provides UV light replacement warning after certain runtime hours.
- ac. The control monitors exhaust air and return airflow.
- ad. The control provides rapid start.
- ae. The control is capable of initiating warm-up and cool down mode using either occupied command, optimal start or schedule.
- af. The control provides staggered start and coast mode.
- ag. The control provides condensate overflow switch alarm.

## BAS communications

The unit has BACnet MS/TP, Modbus, N2 [BACnet IP] communication protocol integral to the unit controller. The controller is certified for BACnet communication protocol by BACnet Testing Laboratory (BTL) to meet the requirements of the advanced application control profile. A control points list, BACnet interoperability building blocks (BIBBs), and protocol implementation conformance statement (PICS) is provided by the manufacturer to facilitate communications programming with the BAS.

1. **Mobile access portal (MAP) gateway [optional]** - MAP Gateway is a pocket-sized web server that provides a wireless mobile UI to Smart Equipment and manufacturer branded system controllers and thermostats. MAP Gateway provides multi-client connectivity, browser-based interface, WiFi connectivity, browser-based remote building management, permanent audit log, portable size and mobility, and an easy-to-use intuitive UI.
2. **Customer terminal board [optional]** - A customer terminal board is supplied on all units requiring twinning, smoke control sequences, humidifier, or hydronic heat.
3. **Verasys™ and Metasys® Communication interface** - The BAS provides the owner with a simple user experience and configurable controls. The system consists of Smart Equipment technology and is able to interface with Verasys™ and Metasys® systems.

## Installation

### General

The installing contractor installs the rooftop unit(s), including components and controls required for operation, in accordance with the rooftop unit manufacturer's written instructions and recommendations. Rooftop units are installed as specified.

- All size or shape equipment including electrical components, especially those not built with weatherproof enclosures, VFDs, and end devices are effectively covered for protection against rain, snow, wind, dirt, sun fading, road salt/chemicals, rust, and corrosion during shipping cycle. Equipment remains clean and dry.

### Location

Locate the rooftop unit as indicated on drawings, including cleaning and service maintenance

clearance per manufacturer instructions. Adjust and level the rooftop unit on the support structure.

## Inspection and start-up supervision [optional]

A factory-trained service representative of the manufacturer supervises the unit start-up and application specific calibration of control components.

