

INSTALLATION MANUAL

R-454B

Models: KE090

KC120 to 300

KD120 to 240

7.5 to 25 ton 60 Hertz

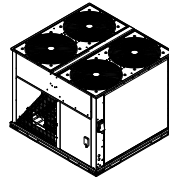

Table of contents

Nomenclature	2	Rigging	7
General	2	Phasing	8
DS Solutions App	3	Electrical data	9
Renewal parts	3	Refrigerant mains	11
Agency approvals	3	Piping and electrical connections	18
Inspection	3	Start-up	18
Physical data	4	Crankcase heater	18
Installation	5	Operation	19
Preceding installation	5	Sequence of operation	19
Limitations	5	Cooling sequence of operation	19
Location	5	Control board navigation components	21
Clearances	7	Start-up sheet	32

List of tables

KE090, KC120 - 300 and KD120 - 240 physical data	4	Electrical data - outdoor unit -	
Unit application data	5	AC with powered convenience outlet	10
Corner weights and center of gravity	6	KE090, KC/KD120, and KC/KD150 unit height dimensions	16
Minimum clearances	7	KC180 and KC240 unit height dimensions	18
Electrical Data - outdoor unit -		Piping And electrical connection sizes (in.)	18
AC without powered convenience outlet	9	Smart Equipment UCB details (Version 5 hardware)	22
		Cable for FC Buses and SA Buses in Order of Preference	28

List of figures

Corner weights and center of gravity	6	KC/KD180 and KC/KD240 unit dimensions and piping and electrical dimensions	17
Typical rigging	7	Fan Orientation - Control Box End	21
Typical simplified field wiring diagram –		CWCVT (S1-TL-CWCVT-0)	21
GL090 evaporator with KE090 condenser	13	Communication card	21
Typical simplified field wiring diagram – GL120 to 240		Unit control board	22
evaporator with KC120 to 240 condenser	14	KE090 charging chart	29
Typical GL120 - 240 liquid line solenoid wiring	14	KC120 charging chart	29
Typical simplified field wiring diagram – GM120 to 240		KC150 charging chart	30
evaporator with KD120 to 240 condenser	15	KC180 charging chart	30
Typical field wiring diagram -		KC240 charging chart	31
GC300 evaporator unit with KC300 condenser unit	15	KC300 charging chart	31
KE090, KC/KD120, and KC/KD150 unit dimensions 16			

DS Solutions App

Johnson Controls believes in empowering our customers with unit-specific information at all times, even on the roof. Download the DS Solutions application, available through the Apple App Store and the Google Play store. Users can use DS Solutions to scan the QR code located on the rating plate that is unique to each unit and provides information specific to the product. Take advantage of the features available for all units: Nomenclature, Literature (Technical Guide, Installation Manual and Wiring Diagrams), Parts list, Product Registration, Claims Tracking, and more.



Safety considerations

Installer should pay particular attention to the words: *NOTE*, *CAUTION*, and *WARNING*. Notes are intended to clarify or make the installation easier. Cautions are given to prevent equipment damage. Warnings are given to alert installer that personal injury and equipment damage may result if installation procedure is not handled properly.

! WARNING

Improper installation may create a condition where the operation of the product could cause personal injury or property damage. Improper installation, adjustment, alteration, service or maintenance can cause injury or property damage. Refer to this manual for assistance or for additional information, consult a qualified contractor, installer or service agency.

! WARNING

Before performing service or maintenance operations on unit, turn off main power switch to unit. Electrical shock could cause personal injury. Improper installation, adjustment, alteration, service or maintenance can cause injury or property damage. Refer to this manual. For assistance or additional information consult a qualified installer, service agency or the gas supplier.

! WARNING

Unit is pressurized with a nitrogen holding charge. Vent through service valves before removing refrigerant line caps.

Reference

This instruction covers the installation and operation of the basic condensing unit. For refrigerant piping installation instructions refer to document 247077 "Application Data - General Piping Recommendations for Split System Air Conditioning and Heat Pumps". For information on the installation and operation of the evaporator blower units, refer to the Installation Manual that comes with the unit.

All accessories come with a separate Installation Manual.

Renewal parts

Contact your local Source 1 Distribution Center for authorized replacement parts.

Agency approvals

Design certified by CSA as follows:

- For use as a cooling unit.
- For outdoor installation only.

Inspection

As soon as a unit is received, it should be inspected for possible damage during transit. If damage is evident, the extent of the damage should be noted on the carrier's freight bill. A separate request for inspection by the carrier's agent should be made in writing.

! CAUTION

This product must be installed in strict compliance with the enclosed installation instructions and any applicable local, state and national codes including, but not limited to, building, electrical, and mechanical codes.

Physical data

KE090, KC120 - 300 and KD120 - 240 physical data

Component	Models										
	KE090	KC120	KD120	KC150	KD150	KC180	KD180	KC240	KD240	KC300	
Nominal Tonnage	7.5	10	10	12.5	12.5	15	15	20	20	25	
Refrigerant											
Refrigerant type	R-454B	R-454B	R-454B	R-454B	R-454B	R-454B	R-454B	R-454B	R-454B	R-454B	
Operating charge (lb) ¹	System #1	11.88	16.00	10.25	20.38	12.63	23.25	15.38	34.25	18.38	37.50
	System #2	---	---	9.50	---	12.75	---	15.50	---	20.63	---
Holding charge	Nitrogen										
Dimensions (in.)											
Length	59.1	59.1	59.1	59.1	59.1	59.1	59.1	59.1	59.1	59.1	
Width	31.9	31.9	31.9	31.9	31.9	64.1	64.1	64.1	64.1	64.1	
Height	44.5	50.0	50.0	50.0	50.0	44.5	44.5	50.0	50.0	50.0	
Weights (lb)											
Shipping	387	435	464	519	512	818	847	935	930	1069	
Operating	384	432	461	516	509	815	844	932	927	1066	
Compressors ²											
Type	Single scroll	Single scroll	Single scroll	Tandem scroll	Single scroll	Tandem scroll	Single scroll	Tandem scroll	Single scroll	Tandem scroll	
Quantity	1	1	2	1	2	1	2	1	2	1	
Nominal capacity (ton)	System #1	7.5	10	5	12.5	6	15	7.5	20	10	25
	System #2	---	---	5	---	6.3	---	7.5	---	10	---
Capacity stages	System #1	2	2	1	2	1	2	1	2	1	2
	System #2	---	---	1	---	1	---	1	---	1	---
Unit Capacity Steps (%)	Stage #1	60	67	---	---	---	---	---	---	---	---
	Stage #2	100	100	---	---	---	---	---	---	---	---
System data											
No. refrigeration circuits	1	1	2	1	2	1	2	1	2	1	
Suction line OD (in.)	1 1/8	1 3/8	1 1/8	1 3/8	1 1/8	1 5/8	1 1/8	1 5/8	1 3/8	1 5/8	
Liquid line OD (in.)	5/8	7/8	5/8	7/8	5/8	7/8	5/8	7/8	5/8	7/8	
Outdoor coil data											
Face area (sq. ft.)	23.8	29.0	29.0	29.0	29.0	47.5	47.5	58.1	58.1	58.1	
Rows	1	1	1	1	1	1	1	1	1	1	
Fins per inch	23	23	23	23	23	23	23	23	23	23	
Tube diameter (in./MM)	0.71 / 18	0.71 / 18	0.71 / 18	1.00 / 25	1 / 25	0.71 / 18	0.71 / 18	1.00 / 25	0.71 / 18	1.00 / 25	
Circuitry type	2-pass	2-pass	2-pass	2-pass	2-pass	2-pass	2-pass	2-pass	2-pass	2-pass	
Refrigerant control	---	---	---	---	---	---	---	---	---	---	
Condenser fan data											
No. fans/diameter (in.)	2/24.	2/24	2/24	2/24	2/24	4/24	4/24	4/24	4/24	4/24	
Type	Axial	Axial	Axial	Axial	Axial	Axial	Axial	Axial	Axial	Axial	
Drive type	Direct	Direct	Direct	Direct	Direct	Direct	Direct	Direct	Direct	Direct	
No. speeds	1	1	1	1	1	1	1	1	1	1	
Number of motors	System #1	2	2	2	2	4	2	4	2	4	
	System #2	---	---	---	---	---	2	---	2	---	
Motor HP (ea.)	1/3	3/4	3/4	3/4	3/4	1/3	3/4	3/4	3/4	3/4	
Rotation ³	CW	CW	CW	CW	CW	CW	CW	CW	CW	CW	
RPM	850	1100	1100	1100	1100	850	1100	1100	1100	1100	
Nominal CFM	System #1	7500	9800	7300	9800	8000	15000	9800	17300	9800	19600
	System #	---	---	---	---	---	---	9800	---	9800	---

1. Includes matched indoor blower unit with 25 ft of piping.

2. All compressors include crankcase heaters.

3. When viewing the shaft end of the motor.

Table 1: Unit application data

Voltage Variation ¹ Min. / Max.	208/230-3-60	187/252
	460-3-60	432/504
	575-3-60	540/630
Ambient Air on Condenser Coil Min. /Max.		40°F/125°F ²
Suction Pressure at Compressor and Corresponding Temp. at Saturation Min. / Max.		106.6 psig / 156.6 psig 32.0 °F / 55.0 °F

1.Utilization range "A" in accordance with AHRI Standard 110.

2.These units can operate in an ambient temperature of 125°F providing the wet bulb temperature of the air entering the evaporator coil does not exceed 67°F. Unit can operate to 0°F if equipped with a low ambient kit.

Installation

Preceding installation

If a factory option convenience outlet is installed, the weatherproof outlet cover must be field installed. The cover shall be located in the unit control box. To install the cover, remove the shipping label covering the convenience outlet, follow the instructions on the back of the weatherproof cover box, and attach the cover to the unit using the (4) screws provided.

CAUTION

208/230-3-60 and 380/415-3-50 units with factory installed Powered Convenience Outlet Option are wired for 230v and 415v power supply respectively. Change tap on transformer for 208-3-60 or 380-3-50 operation. See unit wiring diagram.

Limitations

These units must be installed in accordance with all national and local safety codes. If no local codes apply, installation must conform to the appropriate national codes. Units are designed to meet National Safety Code Standards. If components are to be added to a unit to meet local codes, they are to be installed at the dealer's or the customer's expense.

Location

Use the following guidelines to select a suitable location for both the condensing unit and the evaporator.

- The condensing unit is designed for outdoor installation only.
- The condenser fans are the propeller type and are not suitable for use with ductwork in the condenser air stream.
- The condensing unit and the evaporator should be positioned to minimize the number of bends in the refrigerant piping.
- The condensing unit should be as close to the evaporator as practical.
- The condensing unit should not be installed where normal operating sounds may be objectionable.
- The evaporator should be located within the building, either outside or inside the conditioned space.

Rooftop locations

Be careful not to damage the roof. Consult the building contractor or architect if the roof is bonded. Choose a location with adequate structural strength to support the unit.

The condensing unit must be mounted on level supports. The supports can be channel iron beams or wooden beams treated to reduce deterioration.

Minimums of two (2) beams are required to support each unit. The beams should: (1) be positioned perpendicular to the roof joists. (2) Extend beyond the dimensions of the section to distribute the load on the roof. (3) Be capable of adequately supporting the concentrated loads at the corners. These beams can usually be set directly on the roof. Flashing is not required.

Note: On bonded roofs, check for special installation requirements.

Ground level locations

It is important that the units be installed on a substantial base that does not settle, causing strain on the refrigerant lines and possible leaks. Use a one-piece concrete slab with footers that extend below the frost line. Do not tie the slab to the building foundation, as noise can telegraph through the slab.

Table 2: Corner weights and center of gravity

Model	Weight (lb.)		Center of Gravity (in.)		4 Point Load Location (lb.)			
	Shipping	Operating	X	Y	A	B	C	D
KE090	387	384	17.9	32.7	94	121	95	74
KC120	435	432	17.2	33.2	112	133	101	86
KD120	464	461	17.8	31.6	109	139	119	93
KC150	519	516	17	32.2	132	152	124	108
KD150	512	509	18.1	33.6	126	167	123	93
KC180	818	815	30.9	29.9	214	199	194	208
KD180	847	844	28	32.6	262	204	165	212
KC240	935	932	30.75	30	246	228	220	238
KD240	935	932	32	31.3	247	247	219	219
KC300	1069	1066	30.4	30.7	291	263	243	268

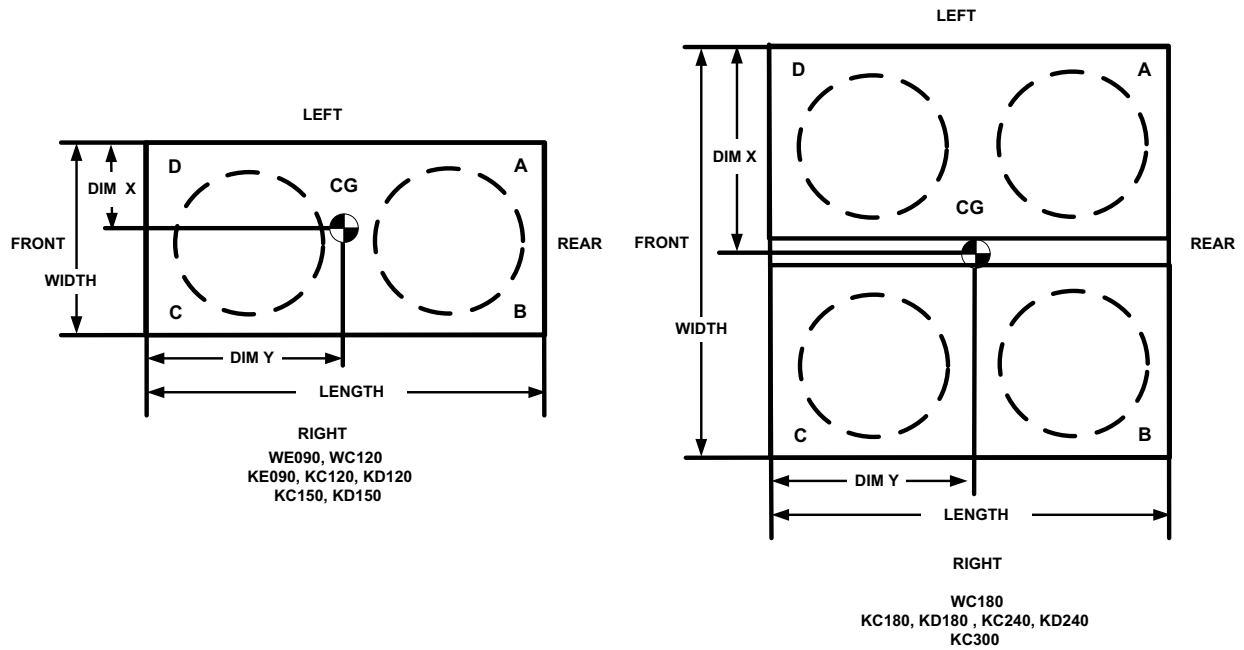

Figure 1: Corner weights and center of gravity

Note: Front of unit is considered the side having the unit control box.

Concrete piers can also support ground level units. These piers should (1) extend below the frost line, (2) be located under each of the section's four corners, and (3) be sized to carry the load of the corner it supports.

On either rooftop or ground level installations, rubber padding can be applied under the unit to lessen any transmission of vibration.

For ground level installations, precautions should be taken to protect the unit from tampering and unauthorized persons from injury. Screws on access panels prevent casual tampering. Further safety precautions such as a fenced enclosure or locking devices on the panels may be advisable. Check local authorities for safety regulations.

Clearances

The unit must be installed with sufficient clearance for air to enter the condenser coil, for air discharge and for servicing access. See Table 3 for clearances.

Note: Additional clearance is required to remove the compressors out the back of the unit, unless a means is available to lift the compressor out through the top of the unit.

Table 3: Minimum clearances

Clearance Description	Distance (in.)
Overhead (Top)	120
Front	36
Rear	24
Left Side	30
Right Side	30
Bottom ¹	0

1. In all installations where snow accumulates and winter operation is expected, additional height must be provided to insure normal condenser airflow.

WARNING

Do not permit overhanging structures or shrubs to obstruct condenser air discharge.

Rigging

Exercise care when moving the unit. Do not remove any packaging until the unit is near the place of installation. Rig the unit by attaching chain or cable slings to the lifting holes provided in the base rails. Spreader bars, whose length exceeds the largest dimension across the unit, **must** be used across the top of the unit.

The unit may be moved or lifted with a forklift. Slotted openings in the base rails are provided for this purpose.

Length of forks must be a minimum of 60 in..

CAUTION

Spreaders, longer than the largest dimension across the unit must be used across the top of the unit.

WARNING

Before lifting a unit, make sure that its weight is distributed equally on the cables so that it will lift evenly.

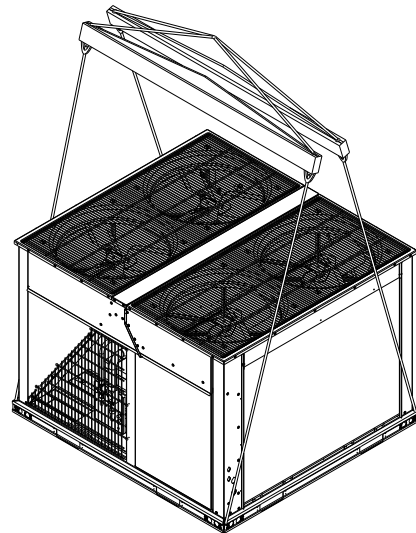

Figure 2: Typical rigging

Power wiring

Check the available power and the unit nameplate for correct voltage. Run the necessary number of properly sized wires to the unit. Provide a disconnect switch (if not included with the unit) and fusing as required (factory disconnect is a fused disconnect). Route the conduit through the large knockout located on the front of the electrical box. See Table 5 for Electrical Data.

The disconnect switch may be bolted to the side of the unit but not to any of the removable panels; this would interfere with access to the unit. Make sure that no refrigerant lines are punctured when mounting the disconnect switch, and note that it must be suitable for outdoor installation.

WARNING

All power and control wiring must be in accordance with National and Local electrical codes.

Control wiring

Route the necessary low voltage control wires from the Smart Equipment™ control board to the thermostat and also from the low voltage condenser unit control box to the terminal block inside the evaporator unit. See Figures 3 through 6 for field wiring diagrams.

Compressors

The scroll compressors used in this product are specifically designed to operate with R-454B Refrigerant and cannot be interchanged.

The compressor also uses a polyolester (POE oil), Mobil 3MA POE. This oil is extremely hygroscopic, meaning it absorbs water readily. POE oil can absorb 15 times as much water as other oils designed for HCFC and CFC refrigerants. Take all necessary precautions to avoid exposure of the oil to the atmosphere.

CAUTION

Do not leave the system open to the atmosphere. Unit damage could occur due to moisture being absorbed by the **POE oil** in the system. This type of oil is highly susceptible to moisture absorption

POE (polyolester) compressor lubricants are known to cause long term damage to some synthetic roofing materials.

CAUTION

Exposure, even if immediately cleaned up, may cause embrittlement (leading to cracking) to occur in one year or more. When performing any service that may risk exposure of compressor oil to the roof, take precautions to protect roofing.

Procedures which risk oil leakage include, but are not limited to, compressor replacement, repairing refrigerant leaks, replacing refrigerant components such as filter drier, pressure switch, metering device or coil.

Units are shipped with compressor mountings which are factory adjusted and ready for operation.

CAUTION

Do not loosen compressor mounting bolts.

Phasing

Three-phase, scroll compressors operate in only one direction. If the scroll is drawing low amperage, has similar suction and discharge pressures, or is producing a high noise level, the scroll is misphased. Change the incoming line connection phasing to obtain the proper rotation.

CAUTION

Scroll compressors require proper rotation to operate properly. Failure to check and correct rotation may result in property damage.

Electrical data

Table 4: Electrical Data - outdoor unit - AC without powered convenience outlet

Model	Compressors		Compressor #1			Compressor #2			Outdoor Fan Motor				Pwr Conv Outlet	Minimum Circuit Ampacity ¹	Maximum Fuse Size (A) ²
	Power Supply	Qty	RLA (each)	MCC (each)	LRA (each)	RLA (each)	MCC (each)	LRA (each)	Power Supply	HP	Qty	FLA (each)	FLA		
KE090	208/230-3-60	1	26.3	41	178.5	-	-	-	208/230-1-60	1/3	2	1.65	-	36.2	50
	460-3-60	1	11	17	95.3	-	-	-	460-1-60	1/3	2	1.1	-	16	25
	575-3-60	1	9.2	14	65	-	-	-	575-1-60	1/3	2	0.65	-	12.8	20
KC120	208/230-3-60	1	26.5	41	255	-	-	-	208/230-1-60	3/4	2	2.8	-	38.7	50
	460-3-60	1	13.8	22	123	-	-	-	460-1-60	3/4	2	1.6	-	20.5	30
	575-3-60	1	11.5	18	93.7	-	-	-	575-1-60	3/4	2	1.2	-	16.8	25
KD120	208/230-3-60	2	16	25	156.4	16	25	156.4	208/230-1-60	3/4	2	2.8	-	41.6	50
	460-3-60	2	7.1	11	69	7.1	11	69	460-1-60	3/4	2	1.6	-	19.2	25
	575-3-60	2	6.4	10	47.8	6.4	10	47.8	575-1-60	3/4	2	1.2	-	16.8	20
KC150	208/230-3-60	2	22.4	35	166.2	22.4	35	166.2	208/230-1-60	3/4	2	2.8	-	56	70
	460-3-60	2	8.8	14	74.6	8.8	14	74.6	460-1-60	3/4	2	1.6	-	23	30
	575-3-60	2	7.2	11	54	7.2	11	54	575-1-60	3/4	2	1.2	-	18.6	25
KD150	208/230-3-60	2	21.2	33	156.5	21.2	33	156.5	208/230-1-60	3/4	2	2.8	-	54.8	70
	460-3-60	2	9.1	14	74.8	9.1	14	74.8	460-1-60	3/4	2	1.6	-	23.4	30
	575-3-60	2	7.7	12	47.8	7.7	12	47.8	575-1-60	3/4	2	1.2	-	19.2	25
KC180	208/230-3-60	2	27.7	43	178.5	27.7	43	178.5	208/230-1-60	3/4	4	2.8	-	68.9	90
	460-3-60	2	11.5	18	103	11.5	18	103	460-1-60	3/4	4	1.6	-	30.3	40
	575-3-60	2	9	14	78	9	14	78	575-1-60	3/4	4	1.2	-	22.9	30
KD180	208/230-3-60	2	27.7	43	178.5	27.7	43	178.5	208/230-1-60	3/4	4	2.8	-	73.5	100
	460-3-60	2	11.5	18	103	11.5	18	103	460-1-60	3/4	4	1.6	-	32.3	40
	575-3-60	2	9	14	78	9	14	78	575-1-60	3/4	4	1.2	-	25.1	30
KC240	208/230-3-60	2	28.7	45	207.5	28.7	45	207.5	208/230-1-60	3/4	4	2.8	-	81.5	110
	460-3-60	2	12.4	19	100.2	12.4	19	100.2	460-1-60	3/4	4	1.6	-	38.1	50
	575-3-60	2	9	14	78	9	14	78	575-1-60	3/4	4	1.2	-	29.9	40
KD240	208/230-3-60	2	28.5	45	255	28.5	45	255	208/230-1-60	3/4	4	2.8	-	75.3	100
	460-3-60	2	13.5	21	123	13.5	21	123	460-1-60	3/4	4	1.6	-	36.8	50
	575-3-60	2	10.7	17	93.7	10.7	17	93.7	575-1-60	3/4	4	1.2	-	28.9	35
KC300	208/230-3-60	2	40.8	64	270	40.8	64	270	208/230-1-60	3/4	4	2.8	-	103	125
	460-3-60	2	19.4	30	147	19.4	30	147	460-1-60	3/4	4	1.6	-	50.1	60
	575-3-60	2	13.7	21	109	13.7	21	109	575-1-60	3/4	4	1.2	-	35.6	45

1. Based on three, 75°C insulated copper conductors in conduit and ambient of 30°C.
2. Maximum fuse or maximum circuit breaker (HACR type per NEC).
Refer to NEC/NFPA No. 70, Articles 440-11, 12 for information on minimum disconnect sizing.

Electrical data - outdoor unit - AC with powered convenience outlet

Model	Compressors		Compressor #1			Compressor #2			Outdoor Fan Motor				Pwr Conv Outlet	Minimum Circuit Ampacity ¹	Maximum Fuse Size (A) ²
	Power Supply	Qty	RLA (each)	MCC (each)	LRA (each)	RLA (each)	MCC (each)	LRA (each)	Power Supply	HP	Qty	FLA (each)	FLA		
KE090	208/230-3-60	1	26.3	41	178.5	-	-	-	208/230-1-60	1/3	2	1.65	20	46.2	60
	460-3-60	1	11	17	95.3	-	-	-	460-1-60	1/3	2	1.1	20	21	30
	575-3-60	1	9.2	14	65	-	-	-	575-1-60	1/3	2	0.65	20	16.8	25
KC120	208/230-3-60	1	26.5	41	255	-	-	-	208/230-1-60	3/4	2	2.8	20	48.7	70
	460-3-60	1	13.8	22	123	-	-	-	460-1-60	3/4	2	1.6	20	25.5	35
	575-3-60	1	11.5	18	93.7	-	-	-	575-1-60	3/4	2	1.2	20	20.8	30
KD120	208/230-3-60	2	16	25	156.4	16	25	156.4	208/230-1-60	3/4	2	2.8	20	51.6	60
	460-3-60	2	7.1	11	69	7.1	11	69	460-1-60	3/4	2	1.6	20	24.2	30
	575-3-60	2	6.4	10	47.8	6.4	10	47.8	575-1-60	3/4	2	1.2	20	20.8	25
KC150	208/230-3-60	2	22.4	35	166.2	22.4	35	166.2	208/230-1-60	3/4	2	2.8	20	66	80
	460-3-60	2	8.8	14	74.6	8.8	14	74.6	460-1-60	3/4	2	1.6	20	28	35
	575-3-60	2	7.2	11	54	7.2	11	54	575-1-60	3/4	2	1.2	20	22.6	25
KD150	208/230-3-60	2	21.2	33	156.5	21.2	33	156.5	208/230-1-60	3/4	2	2.8	20	64.8	80
	460-3-60	2	9.1	14	74.8	9.1	14	74.8	460-1-60	3/4	2	1.6	20	28.4	35
	575-3-60	2	7.7	12	47.8	7.7	12	47.8	575-1-60	3/4	2	1.2	20	23.2	30
KC180	208/230-3-60	2	27.7	43	178.5	27.7	43	178.5	208/230-1-60	3/4	4	2.8	20	78.9	100
	460-3-60	2	11.5	18	103	11.5	18	103	460-1-60	3/4	4	1.6	20	35.3	45
	575-3-60	2	9	14	78	9	14	78	575-1-60	3/4	4	1.2	20	26.9	35
KD180	208/230-3-60	2	27.7	43	178.5	27.7	43	178.5	208/230-1-60	3/4	4	2.8	20	83.5	110
	460-3-60	2	11.5	18	103	11.5	18	103	460-1-60	3/4	4	1.6	20	37.3	45
	575-3-60	2	9	14	78	9	14	78	575-1-60	3/4	4	1.2	20	29.1	35
KC240	208/230-3-60	2	28.7	45	207.5	28.7	45	207.5	208/230-1-60	3/4	4	2.8	20	91.5	110
	460-3-60	2	12.4	19	100.2	12.4	19	100.2	460-1-60	3/4	4	1.6	20	43.1	50
	575-3-60	2	9	14	78	9	14	78	575-1-60	3/4	4	1.2	20	33.9	45
KD240	208/230-3-60	2	28.5	45	255	28.5	45	255	208/230-1-60	3/4	4	2.8	20	85.3	110
	460-3-60	2	13.5	21	123	13.5	21	123	460-1-60	3/4	4	1.6	20	41.8	50
	575-3-60	2	10.7	17	93.7	10.7	17	93.7	575-1-60	3/4	4	1.2	20	32.9	40
KC300	208/230-3-60	2	40.8	64	270	40.8	64	270	208/230-1-60	3/4	4	2.8	20	113	150
	460-3-60	2	19.4	30	147	19.4	30	147	460-1-60	3/4	4	1.6	20	55.1	70
	575-3-60	2	13.7	21	109	13.7	21	109	575-1-60	3/4	4	1.2	20	39.6	50

1. Based on three, 75°C insulated copper conductors in conduit and ambient of 30°C.
2. Maximum fuse or maximum circuit breaker (HACR type per NEC).
Refer to NEC/NFPA No. 70, Articles 440-11, 12 for information on minimum disconnect sizing.

Refrigerant mains

CAUTION

This Split-System (Air Condensing / Heat Pump / Air Handling) unit is one component of an entire system. As such it requires specific application considerations with regard to the rest of the system (air handling unit, duct design, condensing unit, refrigerant piping and control scheme).

Failure to properly apply this equipment with the rest of the system may result in premature failure and/or reduced performance / increased costs. Warranty coverage specifically excludes failures due to improper application and Ducted Systems specifically disclaims any liability resulting from improper application.

Please refer to the equipment Technical Guide, Installation Manual and the piping applications bulletin 247077 or call the applications department for Ducted Systems @ 1-877-874-SERV for guidance.

Line sizing

When sizing refrigerant pipe for a split-system air conditioner, check the following:

- Suction line pressure drop due to friction.
- Liquid line pressure drop due to friction.
- Suction line velocity for oil return.
- Liquid line pressure drop due to vertical rise. For certain piping arrangements, different sizes of suction line pipe may have to be used. The velocity of the refrigerant vapor must always be great enough to carry the oil back to the compressor.
- **Evaporator Located Below Condenser** - On a split system where the evaporator blower is located below the condenser, the suction line must be sized for both pressure drop and for oil return.
- **Condenser Located Below Evaporator** - When the condenser is located below the evaporator blower, the liquid line must be designed for the pressure drop due to both friction loss and vertical rise. If the pressure drop due to vertical rise and friction exceeds 60 psi, some refrigerant is flashed before it reaches the thermal expansion valve.

Flash gas:

- Increases the liquid line pressure loss due to friction that in turn causes further flashing.
- Reduces the capacity of the refrigerant control device which starves the evaporator.
- Erodes the seat of the refrigerant control device.
- Causes erratic control of the refrigerant entering the evaporator.

Take adequate precautions

Many service problems can be avoided by taking adequate precautions to provide an internally clean and dry system and by using procedures and materials that conform to established standards.

Use hard drawn copper tubing where no appreciable amount of bending around pipes or other obstructions is necessary. If soft copper is used, care should be taken to avoid sharp bends that may cause a restriction. Pack fiberglass insulation and a sealing material such as permagum around refrigerant lines where they penetrate a wall to reduce vibrations and to retain some flexibility.

Support all tubing at minimum intervals with suitable hangers, brackets or clamps.

Braze all copper-to-copper joints with Silfos-5 or equivalent brazing material. Do not use soft solder. Insulate all suction lines with a minimum of 1/2 in. ARMAFLEX or equivalent that meets local codes. Liquid lines exposed to direct sunlight or high temperatures must also be insulated. Never solder suction and liquid lines together. They can be taped together for convenience and support purposes, but they must be completely insulated from each other.

The liquid and suction service ports on the condenser section permit leak testing, evacuation, and partial charging of the field piping and the evaporator without disturbing refrigerant stored in the condenser during initial installation.

Before beginning installation of the main lines, be sure that the evaporator section has not developed a leak in transit. Check pressure at the Schrader valve located on the header of each coil. If pressure still exists in the system, it can be assumed to be leak free. If pressure **does not** exist, the section must be repaired before evacuation and charging is performed.

A filter-drier **must** be field-installed in the liquid line of every system to prevent dirt and moisture from damaging the system. Properly sized filter-driers are shipped with each condensing section.

Note: Installing a filter-drier does not eliminate the need for the proper evacuation of a system before it is charged.

A field-installed moisture indicating sight-glass should be installed in the liquid lines between the filter-drier and the evaporator coil. The moisture indicating sight-glass can be used to check for excess moisture in the system.

Both condenser and evaporator sections have copper sealing disks brazed over the end of liquid and suction connections. The temperature required to make or break a brazed joint is high enough to cause oxidation of the copper unless an inert atmosphere is provided.

Note: Dry nitrogen should flow through the system at all times when heat is being applied and until the joint has cooled. The flow of nitrogen prevents oxidation of the copper lines during installation.

Always punch a small hole in sealing disks before unbrazing to prevent the pressure in the line from blowing them off. Do not use a drill as copper shavings can enter system.

Note: Solenoid and hot gas bypass valves (if used) should be opened manually or electrically during brazing or evacuating.

Note: Schrader valves located on unit service valves should have their stem removed during brazing to prevent damage to the valve.

Start Installation

WARNING

Unit is pressurized with a nitrogen holding charge. Vent through service valves before removing refrigerant line caps.

Start Installation of main lines at the condenser unit. Verify the service valves are fully seated by screwing the stem of both valves down into the valve body until it stops. Remove the Schrader valve stem and connect a low-pressure nitrogen source to the service port on the suction line valve body. Punch a small hole in the sealing disk; the flow of nitrogen prevents any debris from entering the system. Wrap the valve body with a wet rag to prevent overheating during the brazing process. Overheating the valve causes damage to the valve seals. Unbraid the sealing disk, cool the valve body and prepare the joint for connections of the main lines. Repeat for the liquid line valve body.

WARNING

Never remove a cap from an access port unless the valve is fully back-seated with its valve stem in the maximum counter-clockwise position because the refrigerant charge will be lost. Always use a refrigeration valve wrench to open and close these service valves.

Connect the main liquid line to the liquid line service valve on the condenser section, while maintaining a flow of nitrogen. Cool the valve body and replace the Schrader valve stem on the service port of the liquid line service valve.

Install the liquid line from the condenser unit to the evaporator liquid connection, maintaining a flow of nitrogen during all brazing operations.

The filter-drier and sight glass must be located in this line, leaving the O.D. unit.

Connect a low-pressure nitrogen source to the Schrader valve located on the evaporator unit coil headers. Punch a small hole in the sealing disks, the flow of nitrogen prevents any debris

from entering the system. Unbraid both liquid and suction sealing disks and prepare the joints for connections of the main lines.

Connect the main liquid line to the liquid line connection on the evaporator unit, while maintaining a flow of nitrogen.

Make the suction line connection at the evaporator and run the line to the condenser unit. Connect the main suction line to the suction line service line on the condenser unit, while maintaining a flow of nitrogen. Cool the valve body and replace the Schrader valve stem on the service port of the suction line service valve.

Once the brazing process is complete, leak testing should be done on all interconnecting piping and the evaporator before proper evacuation to 500 microns is performed. Once the line set and evaporator unit is properly evacuated the service valves can be opened and the condenser unit is now ready to charge with the appropriate weight of refrigerant.

Calculate the correct system charge for the condenser unit, the evaporator unit and the field line set. Charge the system by introducing liquid refrigerant into the liquid line through the liquid port connection. Complete adding the refrigerant in vapor form into the suction port when the compressor is started.

The correct refrigerant pressures are indicated as shown in Figures 14 through 22.

CAUTION

After initial system startup, running both compressors for fifteen (15) minutes minimum, shut down the system and visually check the oil levels at both tandem compressor sight glasses. It is normal for one compressor oil level to be slightly lower than the other, as long as the oil levels are at the center (or lower third) of the sight glass.

If oil level is below one third of the sight glass, oil must be added. Use POE 32VIS oil or equivalent pumped into the low pressure suction port only.

WARNING

Wear safety glasses and gloves when handling refrigerants. Failure to follow this warning can cause serious personal injury.

Note: This instruction covers the installation and operation of the basic condenser unit. For refrigerant piping installation instructions refer to document 247077 "Application Data - General Piping Recommendations for Split System Air Conditioning and Heat Pumps".

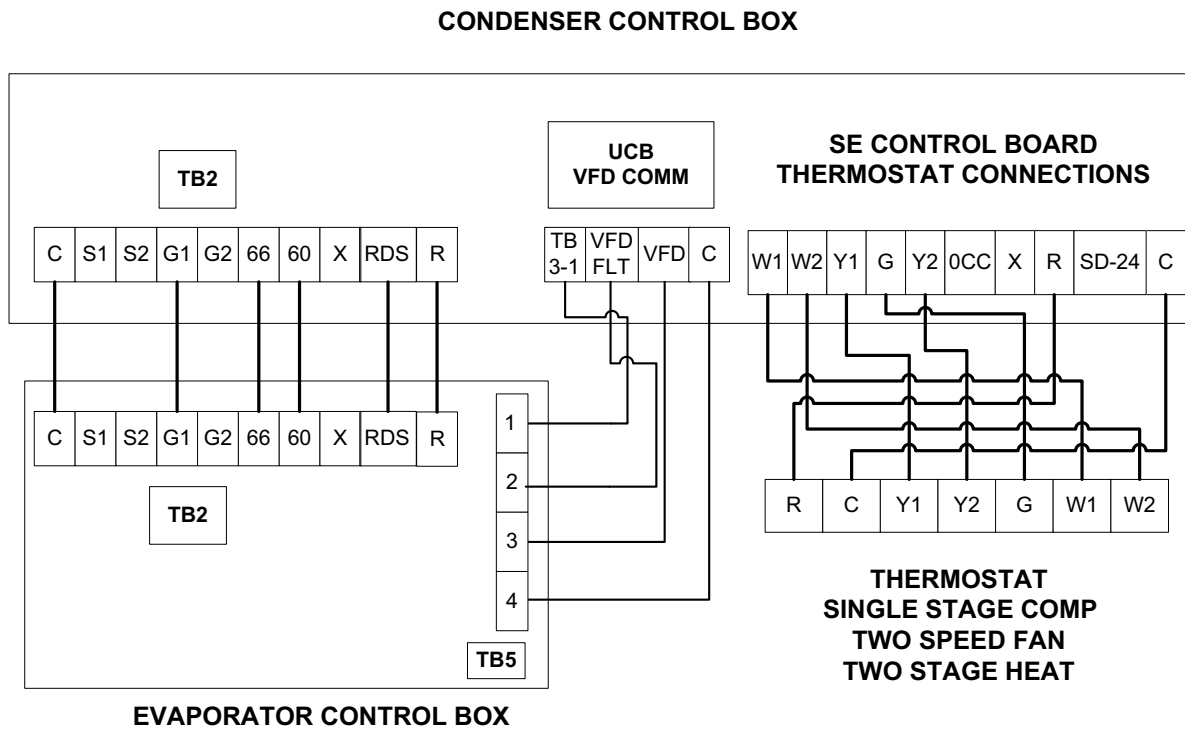

Figure 3: Typical simplified field wiring diagram – GL090 evaporator with KE090 condenser

CONDENSER CONTROL BOX

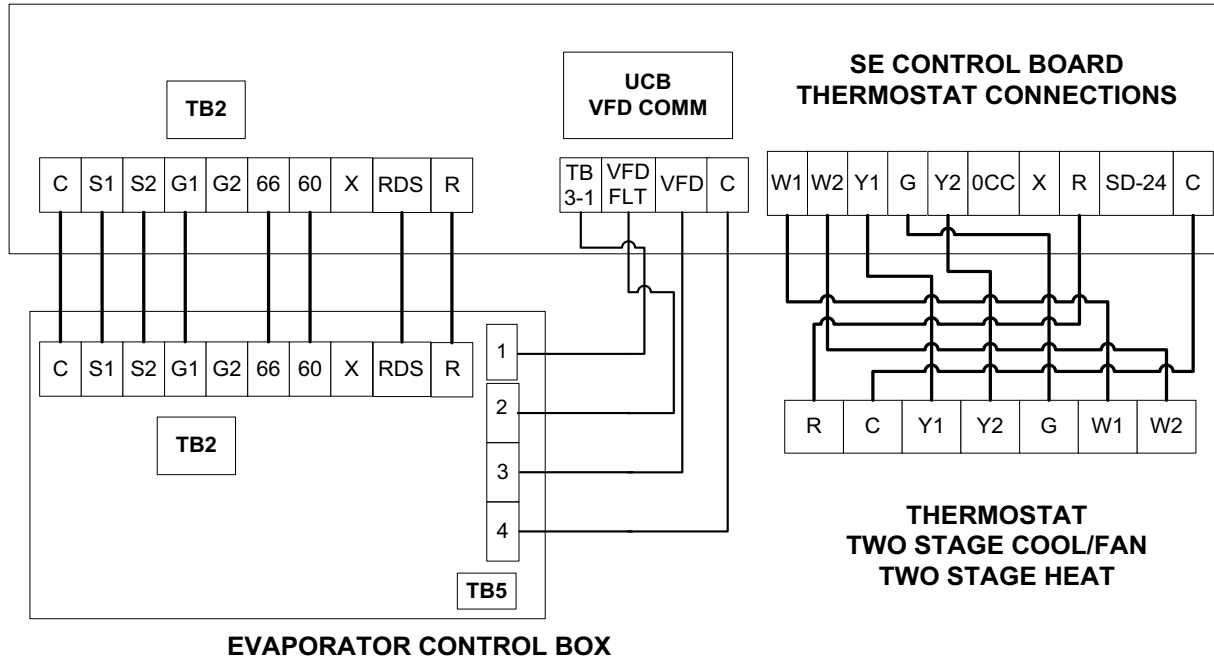

Figure 4: Typical simplified field wiring diagram – GL120 to 240 evaporator with KC120 to 240 condenser

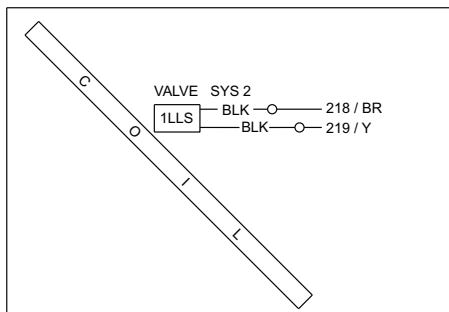

Figure 5: Typical GL120 - 240 liquid line solenoid wiring

CONDENSER CONTROL BOX

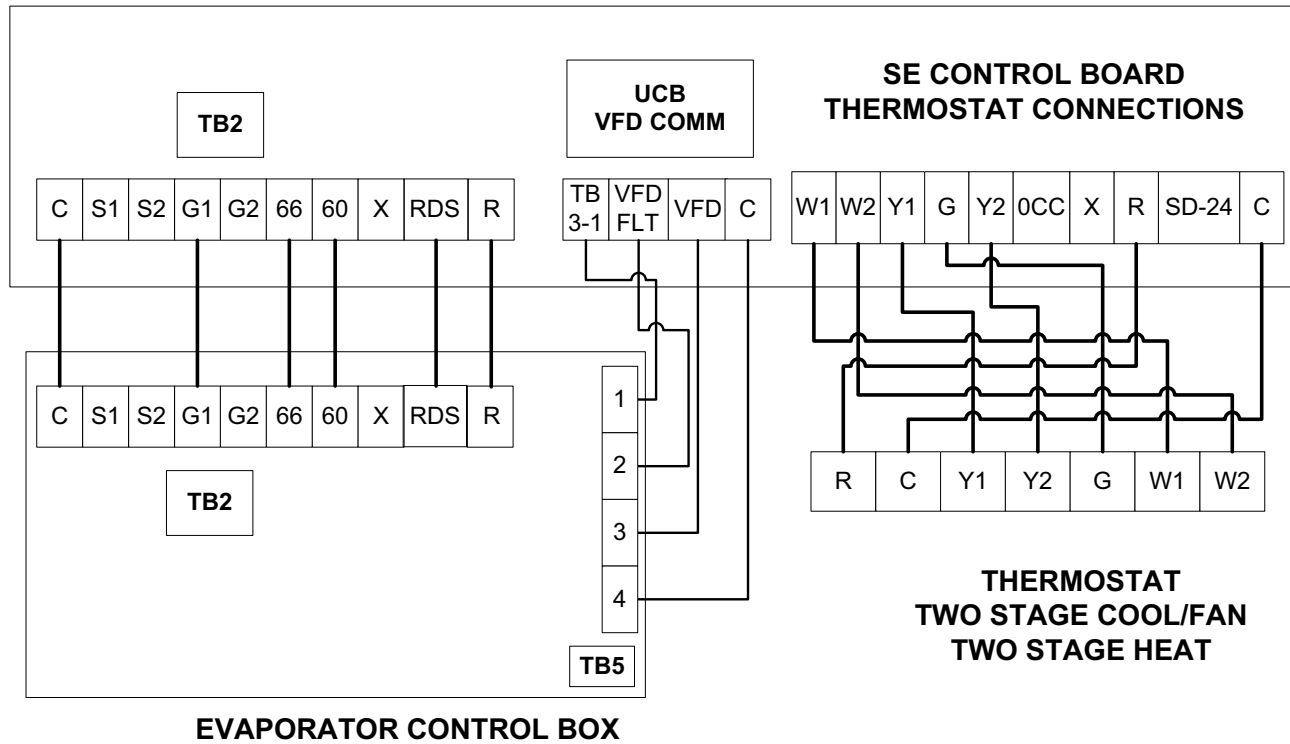

Figure 6: Typical simplified field wiring diagram – GM120 to 240 evaporator with KD120 to 240 condenser

CONDENSER CONTROL BOX

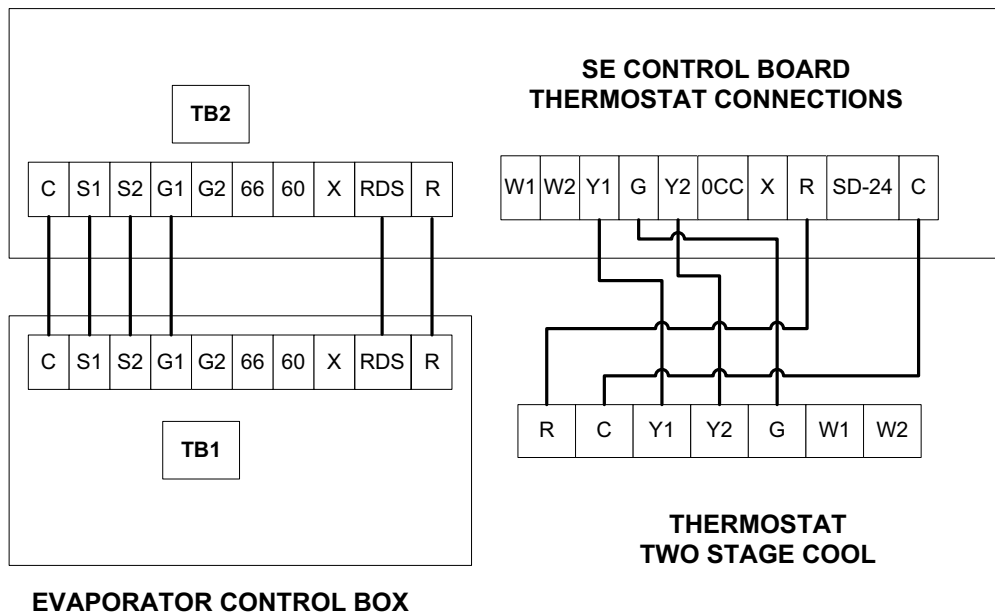

Figure 7: Typical field wiring diagram - GC300 evaporator unit with KC300 condenser unit

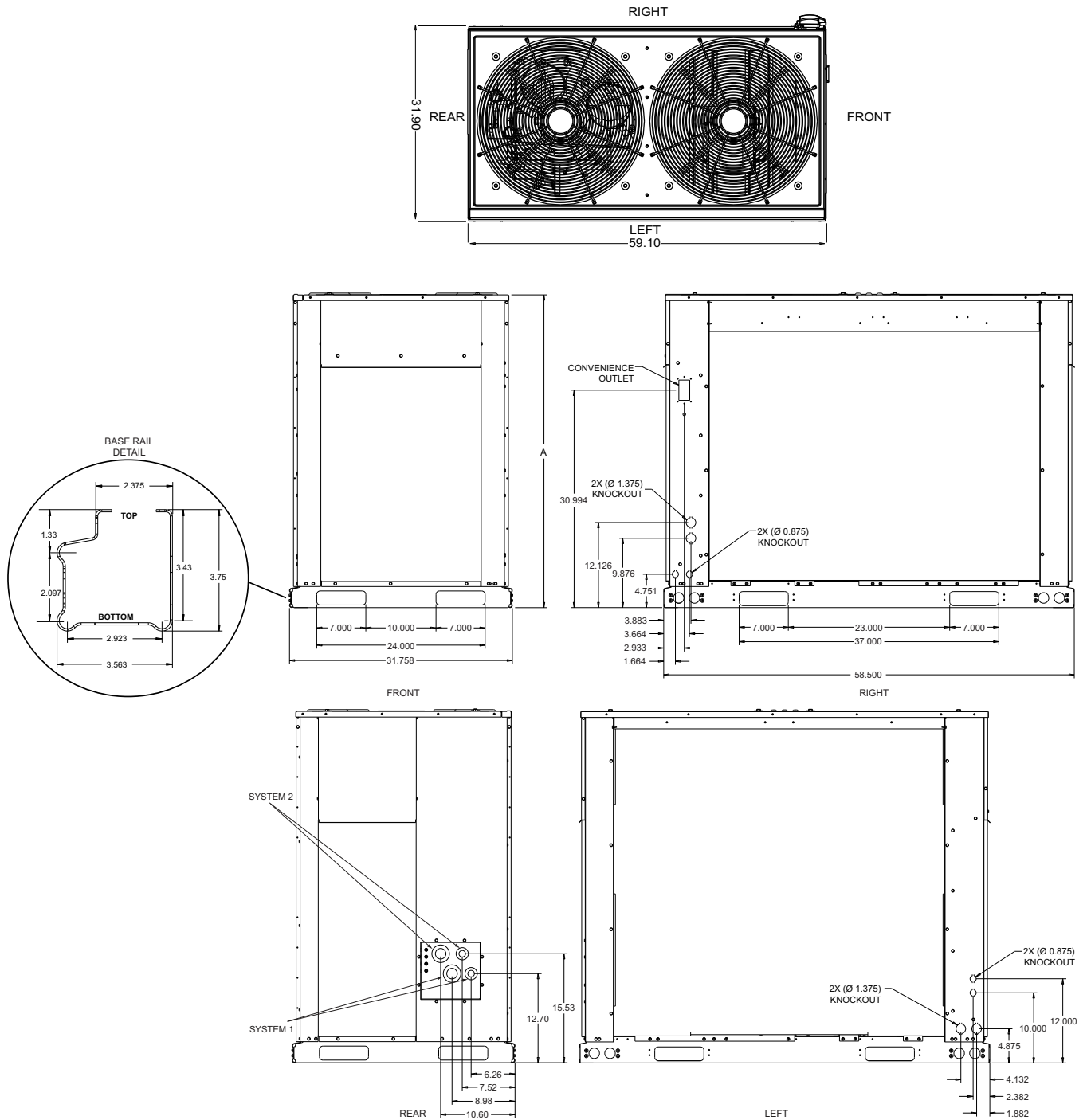

Figure 8: KE090, KC/KD120, and KC/KD150 unit dimensions

Note: Use System 1 piping dimensions when applying a KC120/150, KD120/150 or KE090 model system.

Table 5: KE090, KC/KD120, and KC/KD150 unit height dimensions

Model	A
KE090	44.5
KC120	50.0
KD150	50.0
KC120	50.0
KD150	50.0

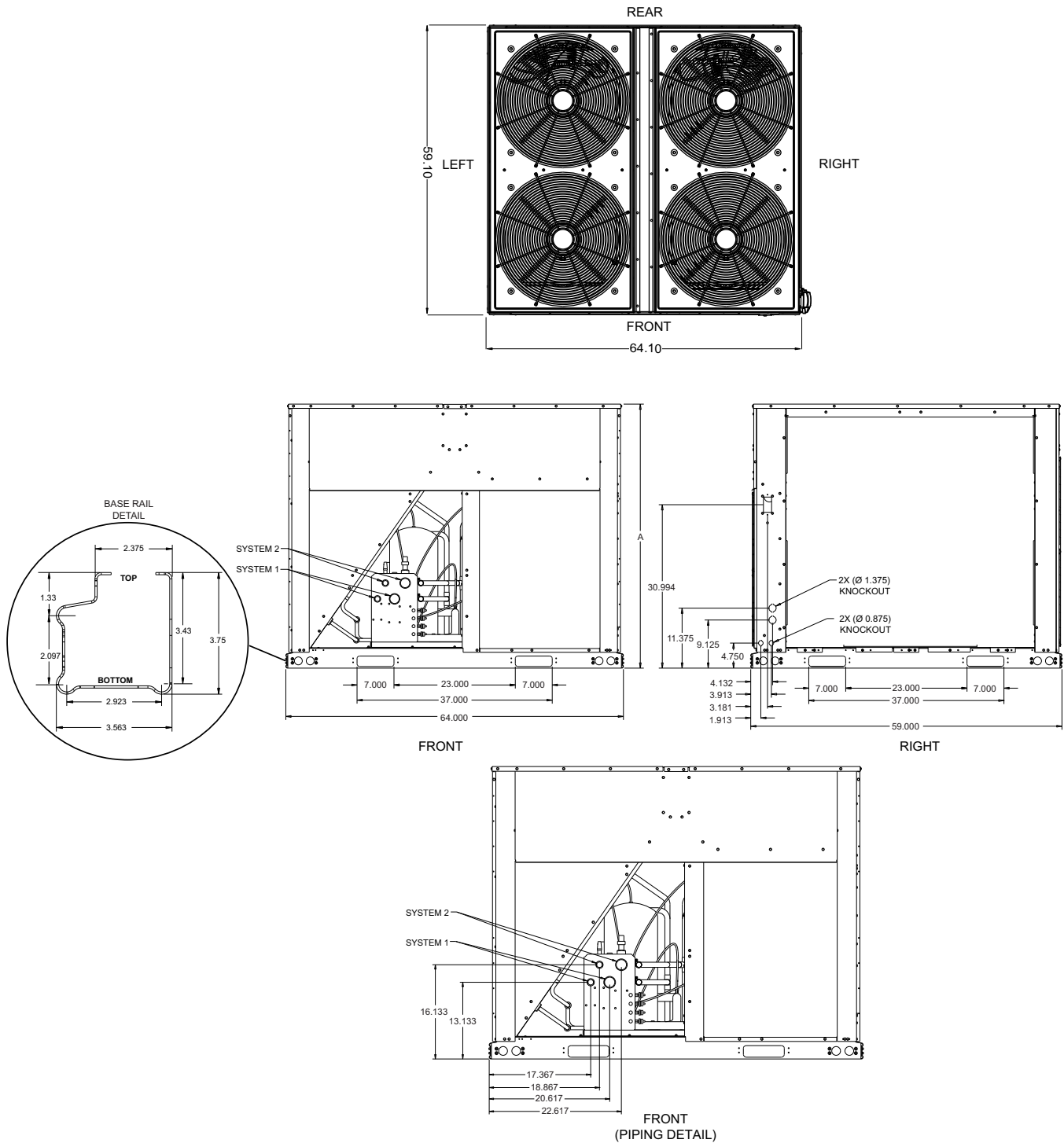

Figure 9: KC/KD180 and KC/KD240 unit dimensions and piping and electrical dimensions

Note: Use System 1 piping dimensions when applying a KC180/240 and KD180/240 model system.

Table 6: KC180 and KC240 unit height dimensions

Model	A
KC180	44.5
KD180	44.5
KC240	50.0
KD240	50.0

Table 7: Piping And electrical connection sizes (in.)

Model	KE090	KC120	KD120	KC150	KD150
No. refrigeration circuits	1	1	2	1	2
Suction line OD (in.)	1 1/8	1 3/8	1 1/8	1 3/8	1 1/8
Liquid line OD (in.)	5/8	7/8	5/8	7/8	5/8
Power wiring knockout	1 3/8	1 3/8	1 3/8	1 3/8	1 3/8
Control wiring knockout	7/8	7/8	7/8	7/8	7/8

Model	KC180	KD180	KC240	KD240	KC300
No. refrigeration circuits	1	2	1	2	1
Suction line OD (in.)	1 5/8	1 1/8	1 5/8	1 3/8	1 5/8
Liquid line OD (in.)	7/8	5/8	7/8	5/8	7/8
Power wiring knockout	1 3/8	1 3/8	1 3/8	1 3/8	1 3/8
Control wiring knockout	7/8	7/8	7/8	7/8	7/8

Piping and electrical connections

Piping connections are made from the rear of 7.5 through 12.5 Ton units and the front of 15 through 25 Ton units. Connections can be made directly to the suction and liquid line service valves. Piping can be routed to the units from the left or right side.

Electrical connections for power and control wiring are made from the right or left side of all units. See Table 7 and Figures 12 and 9 for piping sizes and electrical knockout details.

Start-up

Crankcase heater

The crankcase heater must be energized at least 8 hours before starting the compressor. To energize the crankcase heater, the main disconnect switch must be closed. During this 8 hour period, the system switch on the room thermostat must be "OFF" to prevent the compressor from starting. Make sure that the bottom of the compressor is warm to the touch to prove crankcase heater operation.

CAUTION

Do not attempt to start the compressor without at least 8 hours of crankcase heat or compressor damage can occur.

Pre-Start check

Before starting the unit, complete the following check list:

- Have sufficient clearances been provided?
- Has all foreign matter been removed from the interior of the unit (tools, construction or shipping materials, etc.)?
- Have the condenser fans been rotated manually to check for free rotation?
- Are all wiring connections tight?
- Does the available power supply agree with the nameplate data on the unit?
- Is the control circuit transformer set for the proper voltage?
- Have the fuses, disconnect switch and power wire been sized properly?
- Are all compressor hold-down nuts properly secured?
- Are any refrigerant lines touching each other or any sheet metal surface? Rubbing due to vibration could cause a refrigerant leak.
- Are there any visible signs of a refrigerant leak, such as oil residue?
- Has the refrigeration system been leak checked, evacuated and had the correctly calculated charge weighted in?
- Is any electrical wire laying against a hot refrigerant line?

Initial start-up

1. Supply power to the unit through the disconnect switch at least 8 hours prior to starting the compressor.

2. Move the system switch on the thermostat to the AUTO or COOL position.
3. Reduce the setting of the room thermostat to energize the compressor.
4. Check the operation of the evaporator unit per the manufacturer's guidelines.
5. With an ammeter, check the compressor amps against the unit data plate.
6. Check for refrigerant leaks.
7. Check for any abnormal noises and vibrations, and make the necessary adjustments to correct fan blades touching shroud, refrigerant lines hitting on sheet metal, etc.
8. After the unit has been operating for several minutes, shut off the main power supply at the disconnect switch and inspect all factory wiring connections and bolted surfaces for tightness.

Operation

Unit control overview

These series of condenser unit, come factory equipped with Smart Equipment™ controls to monitor all unit functionality and safety controls.

Safety controls

The Smart Equipment™ control board incorporates features to monitor safety circuits as well as minimize compressor wear and damage. An anti-short cycle delay (ASCD) is utilized to prevent operation of a compressor too soon after its previous run. Additionally, a minimum run time is imposed anytime a compressor is energized to allow proper oil return to the compressor. The ASCD is initiated on unit start-up and on any compressor reset or lockout.

The Smart Equipment™ control board monitors the following inputs for each cooling system:

- A high-pressure switch is factory installed to protect against excessive discharge pressure due to a blocked condenser coil or a condenser fan motor failure. During cooling operation, if a high-pressure limit switch opens, the Smart Equipment™ control board de-energizes the associated compressors and initiates the 5-minute ASCD. If the call for cool is still present at the end of the ASCD, the control board re-energizes the halted compressor. If a high-pressure switch opens three times within two hours of operation, the Smart Equipment™ control board locks out the associated system compressors and delivers an error message on the LCD.
- A low-pressure switch to protect the unit against excessively low suction pressure is standard on all condensing units. If the low-pressure switch opens during normal operation, the Smart Equipment™ control board de-energizes the compressor, initiates the ASCD, and shuts down the condenser fans. On startup, if the low-pressure switch opens, the Smart Equipment™ control board monitors the low-pressure switch to make sure it

closes within one minute. If it fails to close, the unit shuts down the associated compressor and begins an ASCD. If the call for cool is still present at the end of the anti-short cycle time delay, the control board re-energizes the halted compressor. If a low-pressure switch opens three times within one hour of operation, the Smart Equipment™ control board locks out the associated compressor and delivers an error message on the LCD.

- An ambient air sensor locks out mechanical cooling at 45°F. A factory equipped low ambient option allows the unit to operate down to 0°F. A field installed low ambient kit is also available.

The refrigerant systems are independently monitored and controlled. On any fault, only the associated system is affected by any safety/preventive action. The other refrigerant system continues to operate unless it is affected by the fault as well.

Sequence of operation

Continuous blower

By setting the room thermostat to "ON," the low voltage control circuit from the "R" to "G" is completed and the supply air blower operates continuously.

Intermittent blower

With the room thermostat fan switch set to "AUTO" and the system switch set to either the "AUTO" or "HEAT" settings, the blower is energized whenever a cooling or heating operation is requested. The blower is energized after any specified delay associated with the operation.

When energized in cooling mode, the indoor blower has a minimum run time of 30 seconds. Additionally, the indoor blower has a delay of 10 seconds between operations.

Cooling sequence of operation

Dual stage condensing unit (KE090, KC120)

A two stage cooling thermostat is required to operate the condenser unit.

When the thermostat calls for first-stage cooling (Y1), the UCB closes the coils of Contactor M1 and M3 and relay BR1..

- Relay BR1 sends a 24V signal to G1 of terminal block TB2. It may be used to control operation of an indoor blower.
- Contactor M1 controls compressor COMPR1.
- Contactor M3 controls all outdoor fans.

When the thermostat calls for second-stage cooling (Y2), the UCB closes the coils of the compressor solenoid.

If the initial call for cooling requires both stages (Y1 and Y2), the UCB delays the second stage by 30 seconds to avoid an excessive power inrush.

When the call for cooling (Y2) is satisfied, the UCB disables the signal to Compressor solenoid coil as long as the specified minimum run time (ASCD) has elapsed.

When the call for cooling (Y1) is satisfied, the UCB disables the signal to M1 and G1 as long as the specified minimum run time (ASCD) has elapsed.

Dual stage condenser unit (KC120)

A two stage cooling thermostat is required to operate the condenser unit.

- When the thermostat calls for first-stage cooling (Y1), the UCB closes the coils of contactor M1.
- UCB Output C1 has three functions:
 - Control the crankcase heater CCH1.
 - Control the coil of contactor M1.
 - Control the 24V output signal to S1 on terminal block TB2.
- UCB Output FAN sends a 24V signal to G1 of terminal block TB2. It may be used to control operation of an indoor blower.
- Contactor M1 controls compressor COMPR1.
- Contactor M3 controls all outdoor fans.

When the thermostat calls for second-stage cooling (Y2), the UCB provides 24 VAC to compressor solenoid. UCB Output C2 has two functions.

- Control the compressor solenoid.
- Control the 24V output signal to S2 on terminal block TB2.
- Contactor M2 controls compressor COMPR2.

If the initial call for cooling requires both stages (Y1 and Y2), the UCB delays the second stage by 30 seconds to avoid an excessive power inrush. When the call for cooling (Y2) is satisfied, the UCB disables the signal to RY2 and M2 as long as the specified minimum run time (ASCD) has elapsed. When the call for cooling (Y1) is achieved, the UCB disables the signal to FAN and M1 as long as the specified minimum run time (ASCD) has elapsed.

Dual stage condenser unit (KC150-240)

A two stage cooling thermostat is required to operate the condenser unit.

- When the thermostat calls for first-stage cooling (Y1), the UCB closes the coils of contactor M1.
- UCB Output C1 has three functions. 1) control the crankcase heater CCH1. 2) control the coil of contactor M3. 3) control the 24V output signal to S1 on terminal block TB2.
- UCB Output FAN sends a 24V signal to G1 of terminal block TB2. It may be used to control operation of an indoor blower.
- Contactor M1 controls compressor COMPR1.
- Contactor M3 controls all outdoor fans.

When the thermostat calls for second-stage cooling (Y2), the UCB closes the coils contactor M2.

- UCB Output C2 has three functions. 1) control the crankcase heater CCH2. 2) control the coil of contactor M3. 3) control the 24V output signal to S2 on terminal block TB2.
- Contactor M2 controls compressor COMPR2.

If the initial call for cooling requires both stages (Y1 and Y2), the UCB delays the second stage by 30 seconds to avoid an excessive power inrush.

When the call for cooling (Y2) is achieved, the UCB disables the signal to RY2 and M2 as long as the specified minimum run time (ASCD) has elapsed.

When the call for cooling (Y1) is achieved, the UCB disables the signal to FAN and M1 as long as the specified minimum run time (ASCD) has elapsed.

Dual stage condenser unit (KD180-240)

A two stage cooling thermostat is required to operate the condenser unit.

When the thermostat calls for first-stage cooling (Y1), the UCB closes the coils FAN and contactor M1.

- UCB Output C1 has three functions. 1) control the crankcase heater CCH1. 2) control the coil of contactor M3. 3) control the 24V output signal to S1 on terminal block TB2.
- UCB Output FAN sends a 24V signal to G1 of terminal block TB2. It may be used to control operation of an indoor blower.
- Contactor M1 controls compressor COMPR1.
- Contactor M3 controls outdoor fans ODFAN 1 and 2.

When the thermostat calls for second-stage cooling (Y2), the UCB closes the coils of contactor M2.

- UCB Output C2 has three functions. 1) control the crankcase heater CCH2. 2) control the coil of contactor M4. 3) control the 24V output signal to S2 on terminal block TB2.
- Contactor M2 controls compressor COMPR2.
- Contactor M4 controls outdoor fans ODFAN 3 and 4.

If the initial call for cooling requires both stages (Y1 and Y2), the UCB delays the second stage by 30 seconds to avoid an excessive power inrush.

When the call for cooling (Y2) is achieved, the UCB disables the signal to M2 as long as the specified minimum run time (ASCD) has elapsed.

When the call for cooling (Y1) is achieved, the UCB disables the signal to M1 as long as the specified minimum run time (ASCD) has elapsed.

Low ambient cooling

These units are factory equipped with Outdoor Air Temperature Sensors (OAT) that work through the Smart Equipment™

control board to operate the compressors and condenser fans normally to 45°F ambient temperature. The Electronic Low Ambient Controller 2LA04703**** Accessory is designed to assure safe operation through condenser head pressure regulation down to 0°F ambient temperature.

Low Ambient Control Operation

- A call for cooling closes contactor M3 which energizes all condenser fans on all models except KD180-240. Both M3 and M4 control fans on KD180-240. The Low Ambient Control starts all fans at full speed then adjusts according to the liquid line temperature.

Refer to the appropriate 2LA low ambient kit instructions for additional detail on the factory or field installed low ambient kit and its operation.

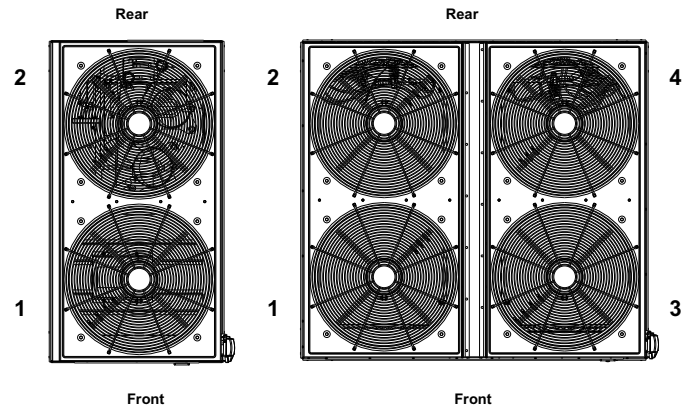

Figure 10: Fan Orientation - Control Box End

Control board navigation components

You need the following components to access the control points in the Smart Equipment control.

Note: Installation and operational guides are available from your equipment dealer or distributor.

- Local LCD on Unit Control Board.
- Tools to interact with the UCB.
 - a Connected Workflow app (CWA) (available for iOS or Android).

Note: You can connect the CWA to the controller via bluetooth through the Connected Workflow Converter (CWCVT) or directly to the UCB if the controller has a communication card.
- CWCVT Wireless MS/TP Converter User Guide, literature part no. 12014120
- Connected Workflow Applications User Guide, literature part no. 12014106

Figure 11: CWCVT (S1-TL-CWCVT-0)



Figure 12: Communication card

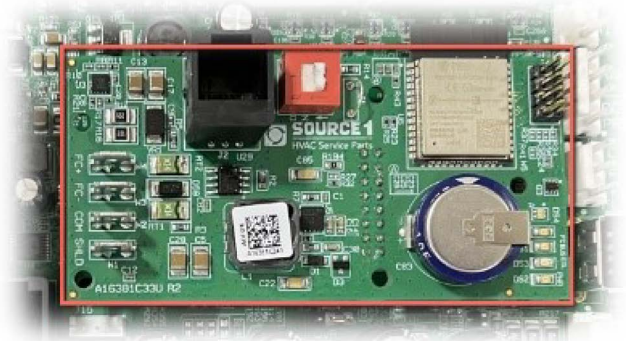

A0210-A-0324

b Mobile Access Portal (MAP) Gateway (portable)

- Source 1 part no. S1-YK-MAP1810-0P (no longer available for purchase).

Note: Although the MAP is no longer available for purchase, it continues to work with the UCB. The MAP does not receive firmware updates, so as additional points are added to the UCB those points will not render properly. However, the MAP will continue to work for the majority of typical applications.

- MAP Gateway Quick Start Guide, part no. 24-10737-16
- MAP Gateway Instruction, part no. 24-10737-8

For more information on the Smart Equipment™ unit control board navigation, refer to the *Smart Equipment™ Quick Start Guide*.

Note: For more in-depth sequence of operation of the Smart Equipment™ control, refer to the *Smart Equipment™ Controls Sequence of Operation Overview LIT-12011950*.

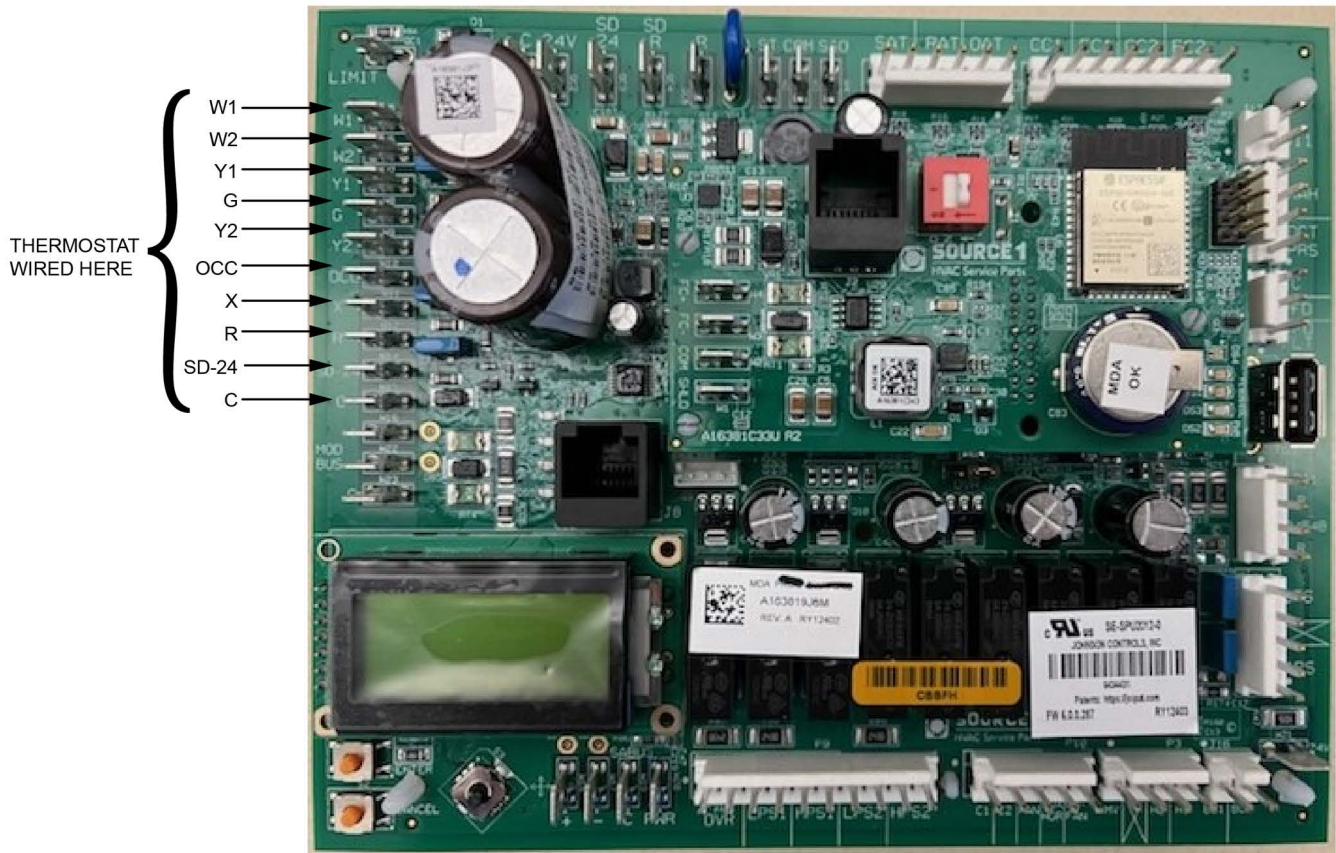

A0209-B

Figure 13: Unit control board

Table 8: Smart Equipment UCB details (Version 5 hardware)

Description	Function and Comments
Terminal Directional orientation: viewed with silkscreen labels upright	
Limit, 24 VAC power and shutdown connections from unit wiring harness at left on upper edge of UCB	
LIMIT	Monitored 24 VAC input through heat section limit switches If the voltage is absent, indicating the heat section is over-temperature, the UCB brings on the indoor blower
C	24 VAC, 75 VA transformer common referenced to cabinet ground Connects through circuit traces to thermostat connection strip C and indoor blower VFD pin C
24V	24 VAC, 75 VA transformer hot Powers the UCB microprocessor, connects through circuit trace to the SD 24 terminal
SD 24	24 VAC hot out for factory accessory smoke detector, condensate overflow and/or user shutdown relay switching in series Connects through circuit trace to thermostat connection strip SD-24. A wiring harness jumper plug connecting SD 24 to SD R is in place if factory accessories for unit shutdown are not used - this jumper plug must be removed if the switching of field-added external accessories for unit shutdown are wired between thermostat connection strip SD-24 and R
SD R	24 VAC hot return from factory accessory smoke detector and user shutdown relay switching in series Connects through circuit trace to the R terminal on the upper left of the board

Table 8: Smart Equipment UCB details (Continued)(Version 5 hardware)

Description		Function and Comments
R	24 VAC hot for switched inputs to the UCB	Connects through circuit trace to the thermostat connection strip R terminal, right FAN OVR pin, right HPS1 pin, right HPS2 pin, lower DFS pin and lower APS pin
Terminal Thermostat connection strip on left edge of UCB		
W1	1st stage heating request, 24 VAC input switched from R	Not effective for cooling-only units
W2	2nd stage heating request, 24 VAC input switched from R	Not effective for cooling-only units or units with single-stage heat sections
Y1	1st stage cooling request, 24 VAC input switched from R	
Y2	2nd stage cooling request, 24 VAC input switched from R	Visible in the display menu when the #ClgStgs parameter is set for 2 or more, also effective for economizer free cooling supply air temperature reset when the #ClgStgs parameter is set for 1 or more
G	Continuous indoor blower request, 24 VAC input switched from R	
OCC	Occupancy request, 24 VAC input switched from R	Must have the OccMode parameter set for External to be effective
X	Hard lockout indicator, 24 volt output to a light thermostat LED	24V positive half-wave rectified
R	24 VAC hot for thermostat switching and power	If field-added external accessories for unit shutdown are used, 24 VAC hot return from smoke detector, condensate overflow and/or user shutdown relay switching in series
SD-24	If field-added external accessories for unit shutdown are used, 24 VAC hot out for smoke detector, condensate over- flow and/or user shutdown relay switching in series	Unit wiring harness jumper plug for factory shutdown accessories must be removed if the switching of field-added external accessories for unit shutdown are wired between thermo- stat connection strip SD-24 and R
C	24 VAC common for thermostat power	
+	Modbus Terminal +	N/A - Future
-	Modbus Terminal -	N/A - Future
C	Modbus Terminal C	N/A - Future
LEDs on left edge of UCB		
Power	Green UCB power indicator	Lit indicates 24 VAC is present at C and 24V terminals
Fault	Red hard lockout, networking error and firmware error indicator	1/2 second on/off flashing indicates one or more alarm is currently active, 1/10th second on/off flashing indicates a networking error (polarity, addressing, etc.) or a firmware error (likely correctable with re-loading from USB flash drive)
SA BUS	Green UCB SA bus communication transmission indicator	Lit/flickering indicates UCB SA bus communication is currently active, off indicates the UCB is awaiting SA bus communication
Terminal Space temperature sensor connections at center on upper edge of UCB		
ST	Space Temperature sensor input from 10K Ω @ 77°F, Type III negative temperature coefficient thermistor	Positive of VDC circuit (3.625 VDC reading to COM with open circuit), effective if "Thermostat-only Control" parameter is set OFF, space sensor override momentary shorts ST to COM to initiate/terminate temporary occupancy
COM	Common for ST and SSO inputs	Negative of VDC circuit for ST and SSO inputs

Table 8: Smart Equipment UCB details (Continued)(Version 5 hardware)

Description		Function and Comments
SSO	Space Sensor Offset input from 0 to 20K Ω potentiometer	Positive of VDC circuit (3.625 VDC reading to COM with open circuit), 10K Ω /2.5 VDC is 0°F offset, 0 Ω /0 VDC is maximum above offset and 20K Ω /3.4 VDC is maximum below offset from active space temperature setpoint
Pin Temperature sensor connections at right on upper edge of UCB		
SAT+	Supply Air Temperature sensor input from 10K Ω @ 77°F, Type III negative temperature coefficient thermistor	Input required for operation; 3.625 VDC reading SAT+ to SAT– with open circuit. Used in heat/cool staging cutouts, free cooling operation, demand ventilation operation, comfort ventilation operation, economizer loading operation, VAV cooling operation, hydronic heat operation.
RAT+	Return Air Temperature sensor input from 10K Ω @ 77°F, Type III negative temperature coefficient thermistor	Input required for operation; 3.625 VDC reading RAT+ to RAT– with open circuit. Used in return air enthalpy calculation. Substitutes for space temperature if no other space temperature input is present.
OAT+	Outside Air Temperature sensor input from 10K Ω @ 77°F, Type III negative temperature coefficient thermistor	Input required for operation but may be a communicated value; 3.625 VDC reading OAT+ to OAT– with open circuit. Used in heat/cool cutouts, low ambient cooling determination, dry bulb free cooling changeover, outside air enthalpy calculation, economizer loading operation, heat pump demand defrost calculation.
CC1+	#1 refrigerant circuit Condenser Coil temperature sensor input from 10K Ω @ 77°F, Type III negative temperature coefficient thermistor	Input required for heat pump units, not required for A/C units; 3.625 VDC reading CC1+ to CC1– with open circuit. Used in heat pump demand defrost calculation.
EC1+	#1 refrigerant circuit Evaporator Coil/Suction line temperature sensor input from 10K Ω @ 77°F, Type III negative temperature coefficient thermistor	Input required for operation; 3.625 VDC reading EC1+ to EC1– with open circuit. Used in suction line temperature safety.
CC2+	#2 refrigerant circuit Condenser Coil temperature sensor input from 10K Ω @ 77°F, Type III negative temperature coefficient thermistor	Input required for 2-compressor heat pump units, not required for 2-compressor A/C units, not active for 1-compressor units; 3.625 VDC reading CC2+ to CC2– with open circuit. Used in heat pump demand defrost calculation.
EC2+	#2 refrigerant circuit Evaporator Coil/Suction line temperature sensor input from 10K Ω @ 77°F, Type III negative temperature coefficient thermistor	Input required for operation of 2-compressor units, not active for 1-compressor units; 3.625 VDC reading EC2+ to EC2– with open circuit. Used in suction line temperature safety.
Pinned connections on right edge of UCB		
AI1	Analog Input 1	Future - 0-10 VDC input
RAH+	Return Air Humidity input from 0-10 VDC @ 0-100% RH sensor	Input required for reheat units, optional in all other units, may be a communicated value. Used in return air enthalpy calculation, temperature/humidity setpoint reset, reheat operation.
DCT PRS+	Supply Duct Pressure input from 0-10 VDC @ 0-5" w.c. sensor	Input required for variable air volume units. Used in VAV indoor blower operation.
C	Common for the VFD output	Negative of the VDC circuit for the VFD output
VFD	2-10 VDC (0-100%) output for the indoor blower Variable Frequency Drive	Output is active with indoor blower operation. For CV units: this output provides stepped IntelliSpeed control of the indoor blower VFD based on fan-only, cooling stage and heating stage outputs. For VAV units: this output provides control of the indoor blower VFD based on supply duct static pressure input and setpoint.
VFDFLT	24 VAC hot input from the normally open VFD alarm contact	The VFD alarm contact switches from R within the unit wiring harness. 24 VAC input results in unit shutdown and a "VFD fault" alarm

Table 8: Smart Equipment UCB details (Continued)(Version 5 hardware)

Description		Function and Comments
J10	Type A female Universal Serial Bus connector	Used for backup, restoration, & copying of board parameters as well as board software updating through a flash drive
COS	24 VAC hot return from Condensate Overflow Switch	Optional input; switch opening will disable the control outputs to the unit compressors. Upon closure, the compressors will begin unit operation after off delay expires
R	24 VAC hot out for COS	Connects through circuit trace to the R terminal
RDS	24 VAC hot return from Refrigerant Detection System	Required input for RDS; when flammable refrigerant is used and RDS is required, the unit will monitor this input and enter mitigation mode if unit RDS contact opens
R	24 VAC hot out for COS	Connects through circuit trace to the R terminal
DFS (upper pin)	24 VAC hot return from Dirty Filter Switch	Optional input; switch closure for greater than 15 seconds during indoor blower operation initiates a notification alarm
DFS (lower pin)	24 VAC hot out for Dirty Filter Switch	Connects through circuit trace to the R terminal
APS (upper pin)	24 VAC hot return from Air Proving Switch	When this optional input is enabled: the air proving switch must close within 30 seconds of initiation of indoor blower operation and not open for greater than 10 seconds during in- door blower operation to allow heat/cool operation and prevent an “APS open” alarm; the air proving switch must open within 30 seconds of termination of indoor blower operation to prevent an “APS stuck closed” notification alarm
APS (lower pin)	24 VAC hot out for Air Proving Switch	Connects through circuit trace to the R terminal
Terminal at lower right corner of UCB		
24V	24 VAC hot for H1, H2, CN-FAN, AUX HGR, FAN C1 and C2 output relay contact switching	Output relay circuitry is isolated from other UCB components and the 24 VAC hot source may be from a second transformer in the unit
Pin Heat section connections at right on lower edge of UCB		
BO2	Binary output 2	Future
BO1	Binary output 2	Future
H1	24 VAC hot output for heat section stage 1	Not effective for cooling-only units. Output if demand is present and permissions allow one stage or two stages of heat section operation
H2	24 VAC hot output for heat section stage 2	Not effective for cooling-only units or units with single-stage heat sections. Output if demand is present and permissions allow two stages of heat section operation
MV	24 VAC hot input confirming heat section operation	Sourced from gas valve in gas heat units or first stage heat contactor in electric heat units. Input within 5 minutes from initiation of H1 output initiates the “Heat On Fan Delay” timer, loss of input following the termination of H1 output initiates the “Heat On Fan Delay” timer, no input within 5 minutes from initiation of H1 output initiates an “Ignition Failure” alarm, input for longer than 5 minutes without H1 output initiates a “Gas Valve Mis-wire” alarm

Table 8: Smart Equipment UCB details (Continued)(Version 5 hardware)

Description		Function and Comments
Pin Cooling and fan output connections at right on lower edge of UCB		
CN-FAN	24 VAC hot output for the condenser fan contactor coil	Output with either C1 or C2 output; interrupted during defrost cycle for heat pump units
AUX HGR	24 VAC hot output for hot gas reheat components	Effective only for reheat units, output with reheat operation
FAN	24 VAC hot output for indoor blower contactor coil/indoor blower VFD enable relay coil	Output with heat/cool operation, G input or schedule demand
C1	24 VAC hot output for compressor 1	If demand is present and permissions allow compressor 1 operation; output with compressor cooling, comfort ventilation cooling, reheat or heat pump heating demands
C2	24 VAC hot output for compressor 2	Not effective for one stage compressor UCBs. If demand is present and permissions allow compressor 2 operation; output with compressor cooling, comfort ventilation cooling or heat pump heating demands
Pin Refrigerant circuit safety switch and indoor blower overload connections at center on lower edge of UCB		
HPS1 (right pin)	24 VAC hot out for refrigerant circuit 1 High Pressure Switch	Connects through circuit trace to the R terminal
HPS1 (left pin)	24 VAC hot return from refrigerant circuit 1 High Pressure Switch	Input is only considered if C1 output is needed; input must be present to allow C1 output. Three HPS1 trips in a two hour period cause a "High Pressure Switch 1 Lockout" and C1 output is then prevented until alarm reset. Connects through circuit trace to the right LPS1 pin.
LPS1 (right pin)	24 VAC hot out for refrigerant circuit 1 Low Pressure Switch	Connects through circuit trace to the left HSP1 pin
LPS1 (left pin)	24 VAC hot return from refrigerant circuit 1 Low Pressure Switch	Input is only considered after 30 seconds of C1 output; afterwards, input must be present to allow C1 output. Three LPS1 trips in a one hour period cause a "Low Pressure Switch 1 Lockout" and C1 output is then prevented until alarm reset.
HPS2 (right pin)	24 VAC hot out for refrigerant circuit 2 High Pressure Switch	Not effective for one stage compressor UCBs. Connects through circuit trace to the R terminal
HPS2 (left pin)	24 VAC hot return from refrigerant circuit 2 High Pressure Switch	Not effective for one stage compressor UCBs. Input is only considered if C2 output is needed; input must be present to allow C1 output. Three HPS2 trips in a two hour period cause a "High Pressure Switch 1 Lockout" and C2 output is then prevented until alarm reset. Connects through circuit trace to the right LPS2 pin.
LPS2 (right pin)	24 VAC hot out for refrigerant circuit 2 Low Pressure Switch	Not effective for one stage compressor UCBs. Connects through circuit trace to the left HSP2 pin
LPS2 (left pin)	24 VAC hot return from refrigerant circuit 2 Low Pressure Switch	Not effective for one stage compressor UCBs. Input is only considered after 30 seconds of C2 output; afterwards, input must be present to allow C2 output. Three LPS2 trips in a one hour period cause a "Low Pressure Switch 2 Lockout" and C2 output is then prevented until alarm reset.
FAN OVR (right pin)	24 VAC hot out for indoor blower FAN Overload relay contact/motor protector switch	Connects through circuit trace to the R terminal
FAN OVR (left pin)	24 VAC hot return from indoor blower FAN Overload relay contact/motor protector switch	Input is only considered if FAN output is needed; input must be present to allow FAN output and unit operation. One FAN OVR trip lasting longer than 5 minutes or three FAN OVR trips in a two hour period cause a "Fan Overload Lockout" and unit operation is then prevented until alarm reset.

Table 8: Smart Equipment UCB details (Continued)(Version 5 hardware)

Description		Function and Comments
Terminal SA BUS connections on at left on lower edge and center of UCB		
PWR	Power for SA ("Sensor-Actuator") BUS devices	Also incorporated in the J8 6-pin phone jack connector at the left-center of the board. Positive of the 15 VDC (reading to C) circuit for powering an optional netstat and/or Multi Touch gateway
C	Common for SA BUS power and communication circuits	Also incorporated in the J8 6-pin phone jack connector at the left-center of the board. Negative of the SA BUS circuits
-	Communication for SA BUS devices	Also incorporated in the J8 6-pin phone jack connector at the left-center of the board. Positive of the VDC (typically, a fluctuating 1.5 to 3.5 volts reading to C; at least 0.25 volts lower than +) SA BUS communication circuit to optional economizer board, 4-stage board, fault detection & diagnostics board, netstat and/or Multi Touch gateway
+	Communication for SA BUS devices	Also incorporated in the J8 6-pin phone jack connector at the left-center of the board. Positive of the VDC (typically, a fluctuating 1.5 to 3.5 volts reading to C; at least 0.25 volts higher than -) SA BUS communication circuit to optional economizer board, 4-stage board, fault detection & diagnostics board, netstat and/or Multi Touch gateway
J8	6-pin phone jack connector	Incorporates the SA BUS terminals for convenience/alternate connection of SA BUS devices, primarily used for temporary service connection of the Multi Touch gateway
Item Integrated user interface at lower left corner of UCB		
Display	On-board, 2-line x 8-character back-lit display	On-board display, buttons and joystick allow access to UCB, economizer, 4-stage and FDD board parameters
ENTER	Button for display menu acknowledgment and navigation	
CANCEL	Button for display menu navigation and zeroing of active compressor ASCD timer	
JOY	4-way Joystick for display menu navigation	
Item USB connector at right of UCB		
J15	Factory wired SA Bus connector	
Optional communication sub-board at center of UCB		
Terminal FC BUS connections on left edge of the communication board		
FC+	FC ("Field Connected") BUS BACnet MSTP communication	Positive of the VDC (typically, a fluctuating 1.5 to 3.5 volts reading to COM; at least 0.25 volts higher than -) FC bus BACnet MSTP communication circuit
FC-	FC ("Field Connected") BUS BACnet MSTP communication	Positive of the VDC (typically, a fluctuating 1.5 to 3.5 volts reading to COM; at least 0.25 volts lower than +) FC bus BACnet MSTP communication circuit
COM	Common for the FC ("Field Connected") BUS BACnet MSTP communication circuit	Negative of the VDC FC bus BACnet MSTP communication circuit
SHLD	Shield for the FC ("Field Connected") BUS BACnet MSTP communication circuit	Earth ground reference of the cable to prevent interference on the FC bus BACnet MSTP communication circuit
Item Selector in red housing at left on top edge of the communication board		
EOL switch	End Of Line selector switch for the FC BUS BACnet MSTP communication circuit	ON selected only for the UCB that is the terminus of the FC bus BACnet MSTP communication cable to prevent signal "bounce-back"

Table 8: Smart Equipment UCB details (Continued)(Version 5 hardware)

Description		Function and Comments
RJ12	Connection to the TMR	Connection used for the wireless Transparent MS/TP Repeater (TMR)
LEDs on the communication board		
Bluetooth (DS4)	Bluetooth signal	Solid OFF means bluetooth disabled. Flashing means the bluetooth is available for a connection. Solid ON means a connection has been made
N/A (DS5)	N/A - no function defined	
FC BUS (DS1)	Green FC bus communication transmission indicator	Lit/flickering indicates outgoing UCB FC bus communication is currently active, off indicates the UCB is awaiting incoming FC bus communication
EOL (DS2)	Green End Of Line indicator	Lit indicates the EOL switch is selected ON
ISO PWR (DS3)	Green communication board Isolated Power indicator	Lit indicates the UCB is supplying power to the communication sub-board
Note: When wiring the unit and other devices using the SA Bus and FC Bus, see <i>Cable for FC Buses and SA buses in order of preference</i> .		

Table 9: Cable for FC Buses and SA Buses in Order of Preference

Bus and Cable Type	Non-Plenum Applications		Plenum Applications	
	Part Number	O.D.	Part Number	O.D.
FC Bus: 22 AWG Stranded, 3-Wire Twisted Shielded Cable	Anixter: CBL-22/3-FC-PVC Belden: B5501FE	0.138 in.	Anixter: CBL-22/3-FC-PLN Belden: B6501FE	0.140 in.
SA Bus (Terminal Block): 22 AWG Stranded, 4-Wire, 2 Twisted-Pair Shielded Cable	Anixter: CBL-22/2P-SA-PVC Belden: B5541FE	0.209 in.	Anixter: CBL-22/2P-SA-PLN Belden: B6541FE	0.206 in.
SA Bus (Modular Jack): 26 AWG Solid 6-Wire, 3 Twisted-Pair Cable2	—	—	Anixter preassembled: CBL-NETWORK25 CBL-NETWORK50 CBL-NETWORK75 CBL-NETWORK100	0.15 in.
FC Bus: 22 AWG Stranded, 3-Wire Twisted Non-Shielded Cable	Belden: B5501UE	0.135 in.	Belden: B6501UE	0.131 in.
SA Bus (Terminal Block): 22 AWG Stranded, 4-Wire, 2 Twisted-Pair Non-Shielded Cable	Belden: B5541UE	0.206 in.	Belden: B6541UE	0.199 in.

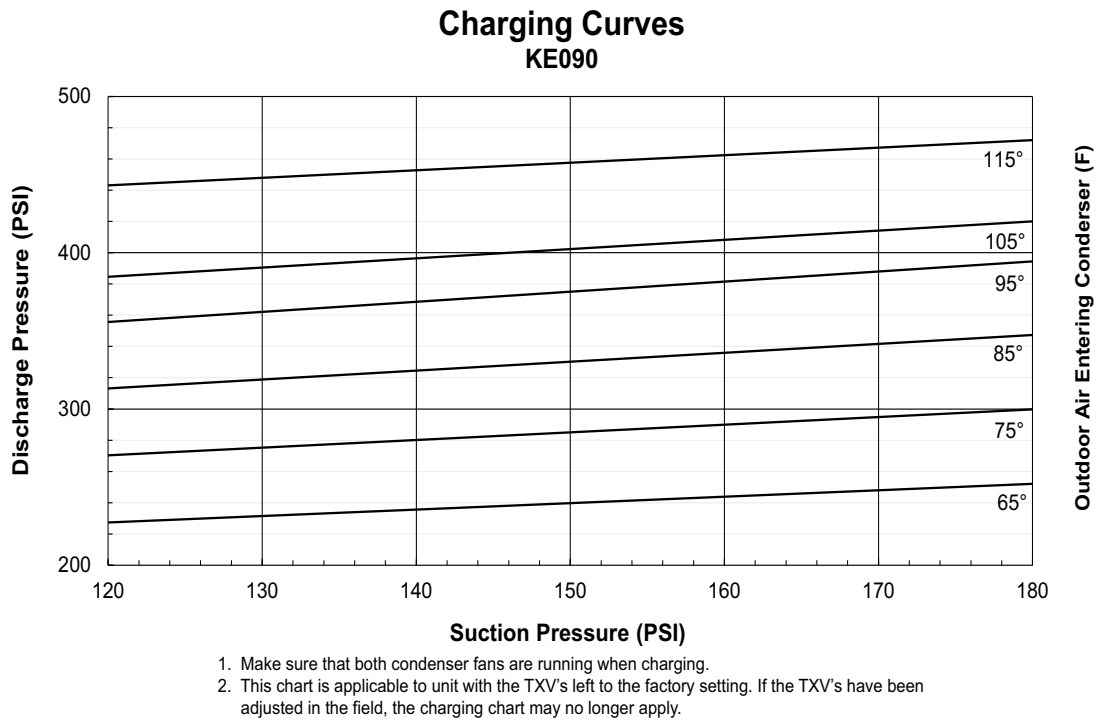

Figure 14: KE090 charging chart

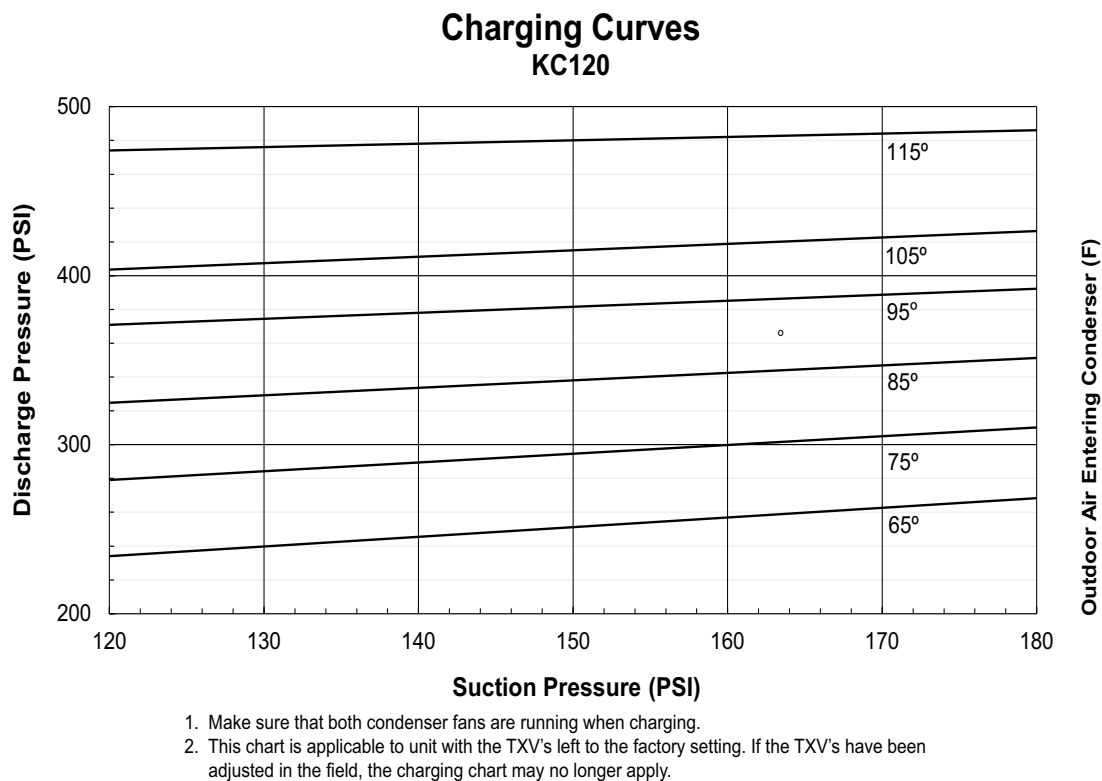
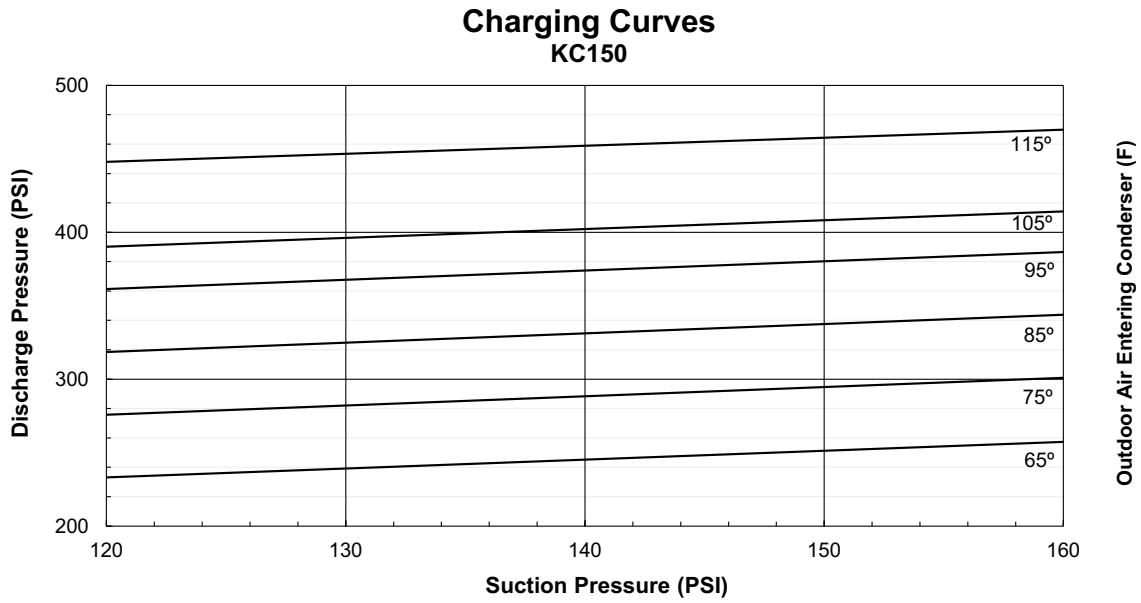
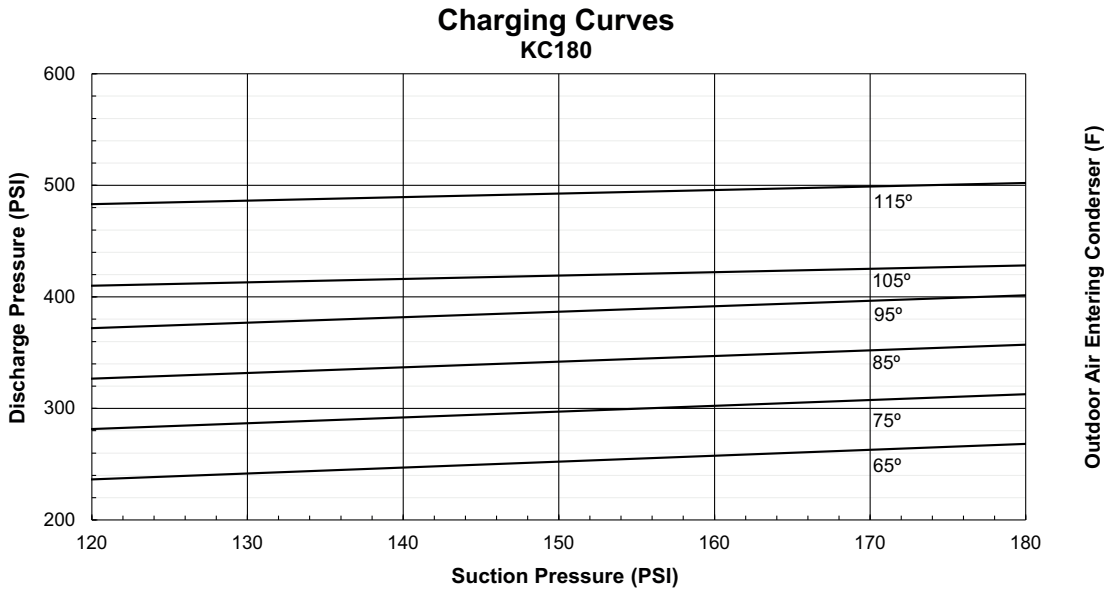

Figure 15: KC120 charging chart



1. Make sure that both condenser fans are running when charging.
2. This chart is applicable to unit with the TXV's left to the factory setting. If the TXV's have been adjusted in the field, the charging chart may no longer apply.

Figure 16: KC150 charging chart



1. Make sure that both condenser fans are running when charging.
2. This chart is applicable to unit with the TXV's left to the factory setting. If the TXV's have been adjusted in the field, the charging chart may no longer apply.

Figure 17: KC180 charging chart

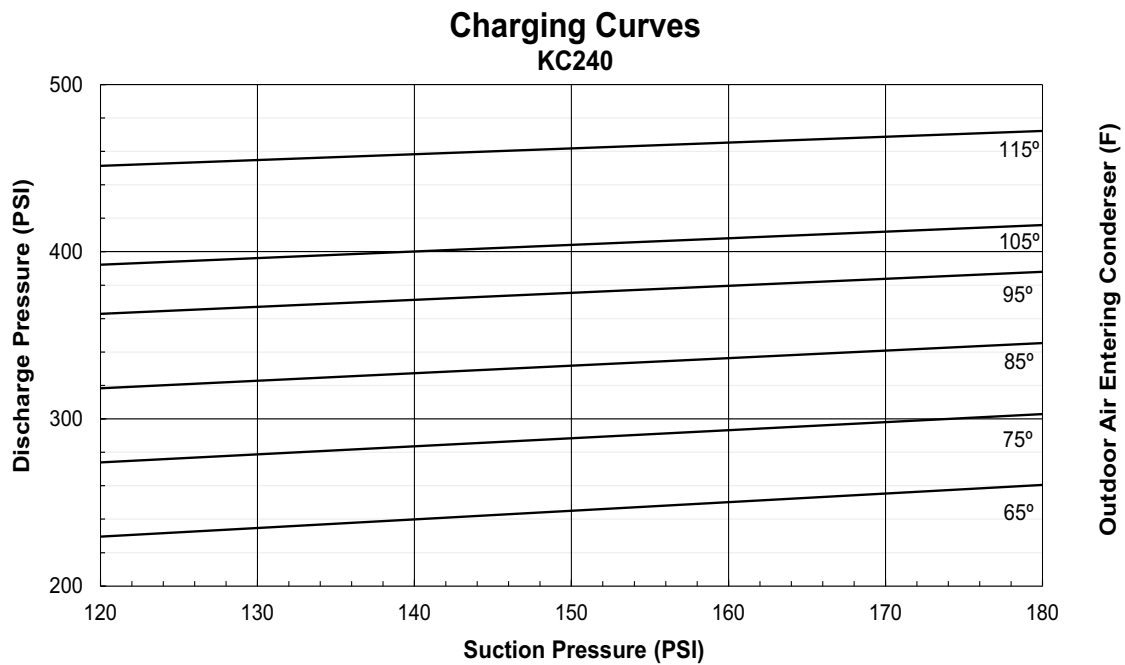

1. Make sure that both condenser fans are running when charging.
2. This chart is applicable to unit with the TXV's left to the factory setting. If the TXV's have been adjusted in the field, the charging chart may no longer apply.

Figure 18: KC240 charging chart

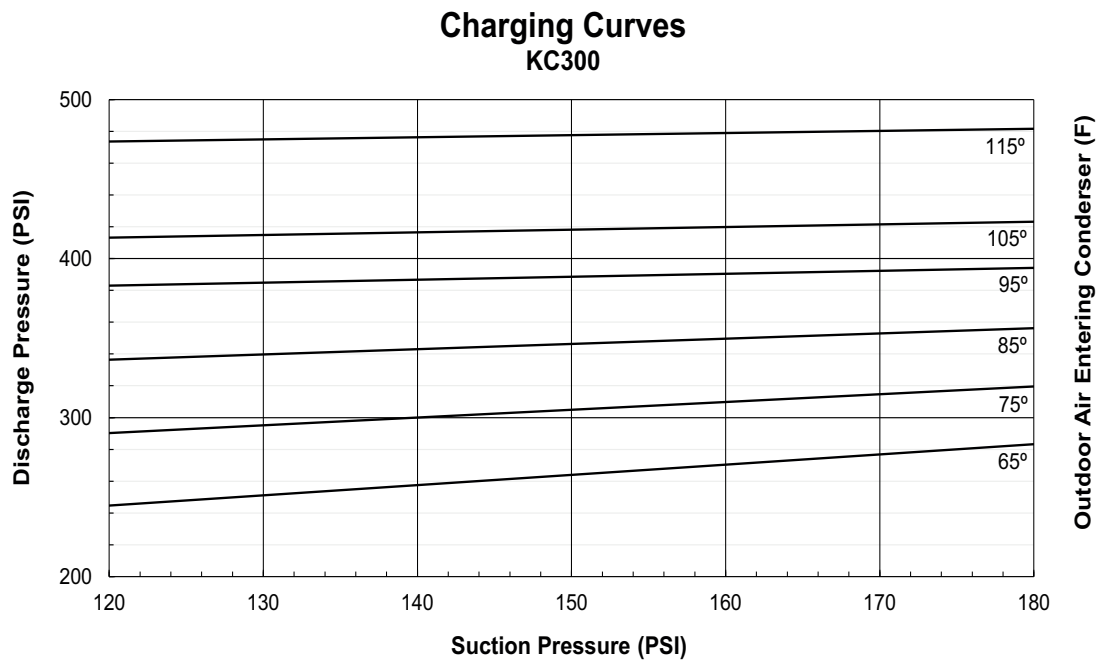

1. Make sure that both condenser fans are running when charging.
2. This chart is applicable to unit with the TXV's left to the factory setting. If the TXV's have been adjusted in the field, the charging chart may no longer apply.

Figure 19: KC300 charging chart

Start-up sheet**START-UP & SERVICE DATA INSTRUCTION****COMMERCIAL SPLIT SYSTEMS**

7.5 To 50.0 TON

START-UP CHECKLIST

Date: _____

Job Name: _____

Customer Name: _____

Address: _____

City: _____ State: _____ Zip: _____

Evaporator Model Number: _____ Serial Number: _____

Condenser Model Number: _____ Serial Number: _____

Qualified Start-up Technician: _____ Signature: _____

HVAC Contractor: _____ Phone: _____

Address: _____

Contractor's E-mail Address: _____

Electrical Contractor: _____ Phone: _____

Distributor Name: _____ Phone: _____

WARRANTY STATEMENT

Johnson Controls/Ducted Systems is confident that this equipment will operate to the owner's satisfaction if the proper procedures are followed and checks are made at initial start-up. This confidence is supported by the 30 day dealer protection coverage portion of our standard warranty policy which states that Johnson Controls/Ducted Systems will cover parts and labor on new equipment start-up failures that are caused by a defect in factory workmanship or material, for a period of 30 days from installation. Refer to the current standard warranty policy and warranty manual for details.

In the event that communication with Johnson Controls/Ducted Systems is required regarding technical and/or warranty concerns, all parties to the discussion should have a copy of the equipment start-up sheet for reference. A copy of the original start-up sheet should be filed with the Technical Services Department.

The packaged unit is available in constant or variable air volume versions with a large variety of custom options and accessories available. Therefore, some variation in the startup procedure will exist depending upon the products capacity, control system, options and accessories installed.

This start-up sheet covers all startup check points common to all package equipment. In addition it covers essential startup check points for a number of common installation options. Depending upon the particular unit being started not all sections of this startup sheet will apply. Complete those sections applicable and use the notes section to record any additional information pertinent to your particular installation.

Warranty claims are to be made through the distributor from whom the equipment was purchased.

EQUIPMENT STARTUP

Use the local LCD or Mobile Access Portal (MAP) Gateway to complete the start-up.

A copy of the completed start-up sheet should be kept on file by the distributor providing the equipment and a copy sent to:

Johnson Controls/Ducted Systems
 Technical Services Department
 5005 York Drive
 Norman, OK 73069

1034350-UCL-F-0924

SAFETY WARNINGS

The inspections and recording of data outlined in this procedure are required for start-up of Johnson Controls/Ducted Systems' packaged products. Industry recognized safety standards and practices must be observed at all times. General industry knowledge and experience are required to assure technician safety. It is the responsibility of the technician to assess all potential dangers and take all steps warranted to perform the work in a safe manner. By addressing those potential dangers, prior to beginning any work, the technician can perform the work in a safe manner with minimal risk of injury.

WARNING

Lethal voltages are present during some start-up checks. Extreme caution must be used at all times.

WARNING

Moving parts may be exposed during some startup checks. Extreme caution must be used at all times.

NOTE: Read and review this entire document before beginning any of the startup procedures.

DESIGN APPLICATION INFORMATION

This information will be available from the specifying engineer who selected the equipment. If the system is a VAV system the CFM will be the airflow when the remote VAV boxes are in the

full open position and the frequency drive is operating at 60 HZ. **Do not proceed with the equipment start-up without the design CFM information.**

Design Supply Air CFM: _____ Design Return Air CFM: _____

Design Outdoor Air CFM At Minimum Position: _____

Total External Static Pressure: _____

Supply Static Pressure: _____

Return Static Pressure: _____

Design Building Static Pressure: _____

ADDITIONAL APPLICATION NOTES FROM SPECIFYING ENGINEER:

1034350-UCL-F-0924

REFERENCE

General Inspection	Completed	See Notes
Unit inspected for shipping, storage, or rigging damage	<input type="checkbox"/>	<input type="checkbox"/>
Unit installed with proper clearances	<input type="checkbox"/>	<input type="checkbox"/>
Unit installed within slope limitations	<input type="checkbox"/>	<input type="checkbox"/>
Refrigeration system checked for gross leaks (presence of oil)	<input type="checkbox"/>	<input type="checkbox"/>
Terminal screws and wiring connections checked for tightness	<input type="checkbox"/>	<input type="checkbox"/>
Filters installed correctly and clean	<input type="checkbox"/>	<input type="checkbox"/>
Condensate drain trapped properly, refer to Installation Manual	<input type="checkbox"/>	<input type="checkbox"/>
All field wiring (power and control) complete	<input type="checkbox"/>	<input type="checkbox"/>

Refrigerant Line Inspection	System 1		System 2	
Is Condenser below Evaporator?	Yes <input type="checkbox"/>	No <input type="checkbox"/>	Yes <input type="checkbox"/>	No <input type="checkbox"/>
Total Line Length end to end.	_____ Ft.		_____ Ft.	
Vertical Lift in Ft.	_____ Ft.		_____ Ft.	
Vertical Fall in Ft.	_____ Ft.		_____ Ft.	
Number of Elbows?	_____ Ea.		_____ Ea.	
Liquid Line Size	_____ Ea.		_____ Ea.	
Suction Line Size	_____ Ea.		_____ Ea.	
Solenoid Valve?	Yes <input type="checkbox"/>	No <input type="checkbox"/>	Yes <input type="checkbox"/>	No <input type="checkbox"/>
Check Valves?	Yes <input type="checkbox"/>	No <input type="checkbox"/>	Yes <input type="checkbox"/>	No <input type="checkbox"/>
Check Valves / Solenoid arrangements installed as per the Ducted Systems Piping Guide	Yes <input type="checkbox"/>	No <input type="checkbox"/>	Yes <input type="checkbox"/>	No <input type="checkbox"/>
Oil Separator ?	Yes <input type="checkbox"/>	No <input type="checkbox"/>	Yes <input type="checkbox"/>	No <input type="checkbox"/>
Accumulator ?	Yes <input type="checkbox"/>	No <input type="checkbox"/>	Yes <input type="checkbox"/>	No <input type="checkbox"/>
TXV - Hard shutoff	Yes <input type="checkbox"/>	No <input type="checkbox"/>	Yes <input type="checkbox"/>	No <input type="checkbox"/>
Heatpump	Yes <input type="checkbox"/>	No <input type="checkbox"/>	Yes <input type="checkbox"/>	No <input type="checkbox"/>

Air Moving Inspection	Completed	See Notes
Alignment of drive components	<input type="checkbox"/>	<input type="checkbox"/>
Belt tension adjusted properly	<input type="checkbox"/>	<input type="checkbox"/>
Blower pulleys tight on shaft, bearing set screws tight, wheel tight to shaft	<input type="checkbox"/>	<input type="checkbox"/>
Pressure switch or transducer tubing installed properly	<input type="checkbox"/>	<input type="checkbox"/>

1034350-UCL-F-0924

Operating Measurements - Air Flow

Fan operates with proper rotation (All VFD equipped units with the optional Manual Bypass must be phased for correct blower rotation with the Bypass switch set in the LINE position)		ID Fans <input type="checkbox"/>	Exh. Fans <input type="checkbox"/>	Cond. Fans <input type="checkbox"/>
Pressure drop across dry evaporator coil (At maximum design CFM) ¹				IWC
External Static Pressure				IWC
Return Static Pressure				IWC
Supply Static Pressure				IWC
Supply Air CFM Using Dry Coil Chart				CFM
Final Adjusted Supply Air CFM ²				CFM

- Consult the proper airflow to pressure drop table to obtain the actual airflow at the measured pressure differential.
- Was a motor pulley adjustment or change required to obtain the correct airflow?
Was it necessary to increase or decrease the airflow to meet the design conditions?
If the motor pulley size was changed, measure the outside diameters of the motor and blower pulleys and record those diameters here:

Blower Motor HP _____ FLA _____ RPM _____

Pulley Pitch Diameter _____ Turns Out _____ Final Turns Out _____

Blower Pulley Pitch Diameter _____ Fixed Sheave _____

ELECTRICAL DATA

T1 - T2 _____ Volts T2 - T3 _____ Volts

Control Voltage _____ Volts T1 - T3 _____ Volts

Device	Nameplate	Measured List All Three Amperages
Supply Fan Motor ^{1,2}	AMPS	AMPS
Condenser Fan #1	AMPS	AMPS
Condenser Fan #2 (if equipped)	AMPS	AMPS
Condenser Fan #3 (if equipped)	AMPS	AMPS
Condenser Fan #4 (if equipped)	AMPS	AMPS
Compressor #1	AMPS	AMPS
Compressor #2 (if equipped)	AMPS	AMPS
Compressor #3 (if equipped)	AMPS	AMPS
Compressor #4 (if equipped)	AMPS	AMPS

- VAV units with heat section - simulate heat call to drive VAV boxes and VFD/IGV to maximum design airflow position.
- VAV units without heat section - VAV boxes must be set to maximum design airflow position.
Notes above apply for 3rd party application only.

1034350-UCL-F-0924

OPERATING MEASUREMENTS - COOLING

Stage	Discharge Pressure	Discharge Temp.	Liquid Line Pressure At Service Valve	Liquid Line Temp. ¹	Subcooling ²	Suction Pressure	Suction Temp.	Superheat
First ³	#	°	#	°	°	#	°	°
Second (if equipped)	#	°	#	°	°	#	°	°
Third (if equipped)	#	°	#	°	°	#	°	°
Fourth (if equipped)	#	°	#	°	°	#	°	°
Heat Pump 1st Stage	#	°	#	°	°	#	°	°

1. Liquid line temperature should be taken before filter/drier.
2. Subtract 10 psi from discharge pressure for estimated liquid line pressure
3. If Rawal valve installed, contact Technical Service.

Outside air temperature _____ db °F _____ wb °F _____ RH%

Return Air Temperature _____ db °F _____ wb °F _____ RH%

Mixed Air Temperature _____ db °F _____ wb °F _____ RH%

Supply Air Temperature _____ db °F _____ wb °F _____ RH%

REFRIGERANT SAFETIES

Action	Completed	See Notes
Prove Compressor Rotation (3 phase only) by guage pressure	<input type="checkbox"/>	<input type="checkbox"/>
Prove High Pressure Safety, All Systems	<input type="checkbox"/>	<input type="checkbox"/>
Prove Low Pressure Safety, All Systems	<input type="checkbox"/>	<input type="checkbox"/>

REFRIGERANT DETECTION SYSTEM (RDS) SAFETY TEST

Action	Completed	See Notes
Does the System have a Refrigerant Detection System (RDS) installed for R-454B?	<input type="checkbox"/>	<input type="checkbox"/>
Does Control Board Show any RDS alarms?	<input type="checkbox"/>	<input type="checkbox"/>
Are all available RDS Sensors pulsing with a green light?	<input type="checkbox"/>	<input type="checkbox"/>
Caution do not continue until any RDS alarms are resolved		
Prove Refrigerant Detection System Alarm Mitigation (Heating Units) – Shuts Down Active Heat Call ¹	<input type="checkbox"/>	<input type="checkbox"/>
Prove Refrigerant Detection System Alarm Mitigation (Cooling Mode) – Shuts Down Active Cooling Call ¹	<input type="checkbox"/>	<input type="checkbox"/>

1. Complete the above steps by pulling the J1 harness off the UCB during an active call for heat/cooling

1034350-UCL-F-0924

OPERATING MEASUREMENTS ELECTRIC HEATING

Heater kW _____ kW Heater Voltage, Nameplate _____ Volts

Heater Model Number: _____

Serial Number: _____

Heater	Nameplate	Measured List All Three Amperages		
Stage 1	_____ AMPS	_____ AMPS	_____ AMPS	_____ AMPS
Stage 2	_____ AMPS	_____ AMPS	_____ AMPS	_____ AMPS
Stage 3	_____ AMPS	_____ AMPS	_____ AMPS	_____ AMPS
Stage 4	_____ AMPS	_____ AMPS	_____ AMPS	_____ AMPS
Checked Heater Limit		Yes <input type="checkbox"/>	No <input type="checkbox"/>	
Air Moving Switch Installed?		Yes <input type="checkbox"/>	No <input type="checkbox"/>	

OPERATIONAL MEASUREMENTS - STAGING CONTROLS

Verify Proper Operation of Heating/Cooling Staging Controls

Create a cooling demand at the Thermostat, BAS System or Smart Equipment™ Verify that cooling/economizer stages are energized.	<input type="checkbox"/>
Create a heating demand at the Thermostat, BAS System or Smart Equipment™ Verify that heating stages are energized.	<input type="checkbox"/>

Verify Proper Operation of the Variable Frequency Drive (If Required)

Verify that motor speed modulates with duct pressure change.	<input type="checkbox"/>
--	--------------------------

FINAL - INSPECTION

Verify that all operational control set points have been set to desired value Scroll through all setpoints and change as may be necessary to suit the occupant requirements.	<input type="checkbox"/>
Verify that all option parameters are correct Scroll through all option parameters and ensure that all installed options are enabled in the software and all others are disabled in the software. (Factory software settings should match the installed options)	<input type="checkbox"/>
Verify that all access panels have been closed and secured	<input type="checkbox"/>
Save a backup file from the unit control board onto a USB flash drive.	<input type="checkbox"/>

