

SUBMITTAL DATA SHEET

0.5 RT (H,Y)IC1006B21S Non-Ducted 1-Way Cassette Indoor Unit

Job Name:		Location:	
Purchaser:		Order No.:	
Engineer:			
Submitted To:	For:	Ref:	Approval:
Submitted By:			Date:
Unit Designation:		Schedule No.:	Model No.:

FEATURES:

- Slim and stylish design
- Automatic swing louver distributes
- Airflow evenly for uniform temperature

ACCESSORIES:

- Panel for 1 way cassette, standard, P-AP36-56CNA
- Motion Sensor Kit, SOR-NES
- Duct Adapter, PD-100
- Grille for Front Discharge, DG-56SW1
- Air Outlet Shutter Plate, PIS-56LS

Model Name			(H,Y)IC1006B21S		
Power Supply			208/230V 1PH 60Hz		
Nominal Capacity	Cooling	Btu/h	(kW)	6000	(1.8)
	Heating	Btu/h	(kW)	6700	(2.0)
Power Consumption	Cooling	W		30	
	Heating	W		20	
Dimension	Height	in	(mm)	9-1/4	(235)
	Width	in	(mm)	35-7/16	(900)
	Depth	in	(mm)	27-15/16	(710)
Net Weight		lb	(kg)	55	(25)
Refrigerant			R410A		
Refrigerant Piping	Gas Line	in	(ϕ mm)	1/2	(12.7)
	Liquid Line	in	(ϕ mm)	1/4	(6.35)
Min Circuit Amps			A	0.2	
Maximum Fuse Siza			A	15	
Fan Motor Drive			DC \times 1		
Air Flow Rate	Hi2	cfm	(m3/min)	300	(8.5)
	Hi	cfm	(m3/min)	265	(7.5)
	Me	cfm	(m3/min)	229	(6.5)
	Lo	cfm	(m3/min)	212	(6)
Air Filter			Polypropylene		
Sound Pressure Level	Hi2	dB(A)		34	
	Hi	dB(A)		32	
	Me	dB(A)		29	
	Lo	dB(A)		27	
Dimension	Height	in	(mm)	1-3/8	(35)
	Width	in	(mm)	43-5/16	(1100)
	Depth	in	(mm)	31-1/2	(800)
Net Weight		lb	(kg)	10	(4.5)

System Dimensions

Non-Ducted 1-Way Cassette Indoor Unit

Model: (H,Y)IC1006B21S

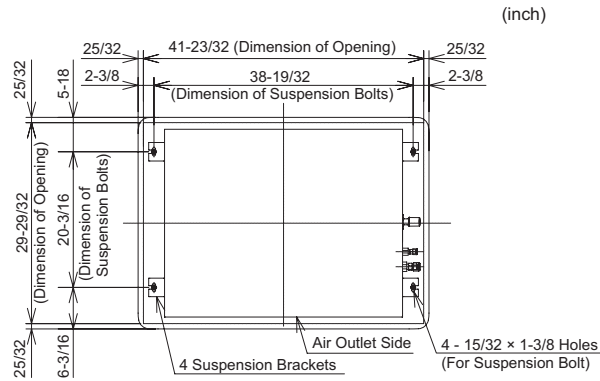

< For a Clipped Ceiling >

In the case of the installation to a clipped ceiling, adjust the distance between the grille for front discharge and the indoor unit as shown in the figure on the right.

NOTE:

Details of installing method of the optional parts for the grille for front discharge and the air outlet shutter plate are listed in each "Installation Manual".

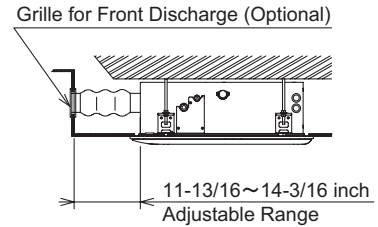

Piping Connection Dimensions

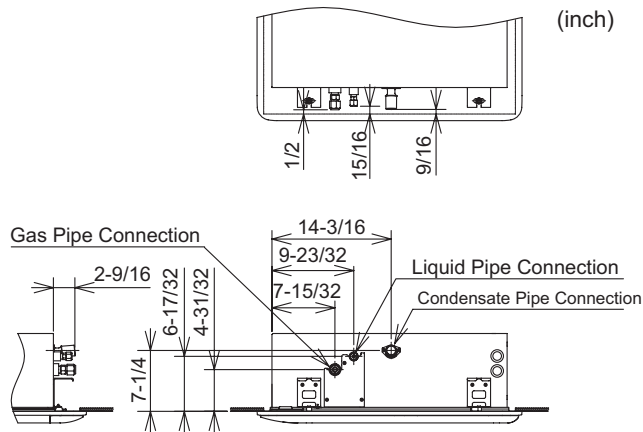

version 201905