

Submittal Data Sheet

4-way Mini 7 UggYthY

4-way Mini 7 UggYthY

K V	O
h	\ V
-	
o u	#
o)
y)	o V U V



95HI F9G

- High performance and high efficiency heat exchanger
- Efficient turbo fan for low-noise performance
- Energy-saving motion sensor that adapts to occupant activity
- Wide range of air flow volume settings

A cXY	fk zMz A \$\$, 6&%G
hXccf l bhDck YfGi dd'm	57 %D\UgYZ&\$, #& \$J z* \$<n
Bca jbu' 7cc'jb[7 UdUMiml%	6h A fLK t Z\$\$\$ f&" t
Bca jbu' <YUrb[7 UdUMiml%	6h A fLK t -Z\$\$\$ f&" t
Gci bX'DfYggi fy'@y Y' fCj Yfu' 5' GWYt	X6 , , ! (! \$! & (")
Ci Yf' 8ja Ybg]cbg	
< Y] \h	jb" fa a t %&%(f&) t
K Xh	jb" fa a t && + #% f) + \$ t
8Ydh	jb" fa a t && + #% f) + \$ t
BYhk Y] \h	Vg fl [t) f% t
F YZ] Yfubh	F (%\$5
hXccf: Ub	
5]f: 'ck 'F UY fk j&<]A Y!@ct	Vza fa ' #a]t (& (!) ' ! ' \$ \$! & % & & fV& \$! , ") ! * t
9l YfbU' DfYggi fy	jb" K ; fDUt \$ "\$ f& t
A chcf Bca jbu' Ci rdi h	K) +
A]b' 7]fW]h5a dg	5 \$ "+
A Ul ja i a : i gY' 5a dg	5 %&
7 cbbYV]cbg	
F YZ] YfubhD]d]b[: 'UY!Bi h7 cbbYV]cb f&]A : 'UY' Bi hgt
@ei X @pY	jb" fa a t %& (f") t
: Ug @pY	jb" fa a t %& fV& "+" \$ t
7 cbXYbgUY' 8fu]b	J D&)
C 8	jb" fa a t %&%(f& t
8	jb" fa a t ' %& & f&) t

5779GGCF 9G

- IR Receiver Kit, CMIRK01
- Motion Sensor Kit, SOR-NEC
- Duct Adapter, PD-75C

5XUdhUVY'DubY' A cXY	P-AP56NAM
7 c'cf	Neutral White
Ci Yf' 8ja Ybg]cbg	
< Y] \h	jb" fa a t 1-3/16(30)
K Xh	jb" fa a t 24-13/32 (620)
8Ydh	jb" fa a t 24-13/32 (620)
BYhk Y] \h	Vg fl [t 6 (3)

BCH9G.
 f% Bca jbu' WdUMim]g VugYX'cb Vza V]bU]cbg k]A]b hAY J F: 'gmg]Ya i bXYfAY Z'ck]b[V&bX]h]cbg.
 7cc'jb[C dYfU]cb 7 cbX]h]cbg
 hXccf 5]f hYhYa dYfU]h fy. , \$.: '86 f&*" +.7 '86 t
 * +. : K 6 f% (.7 K 6 t
 Ci hXccf 5]f hYhYa dYfU]h f -) .: '86 fl) "\$.7 '86 t
 < YUrb[C dYfU]cb 7 cbX]h]cbg
 hXccf 5]f hYhYa dYfU]h fy. +\$.: '86 f&%" .7 '86 t
 Ci hXccf 5]f hYhYa dYfU]h f (+. : '86 fl " .7 '86 t
 (' .: K 6 f% .7 K 6 t
 D]d]b[@yb[h. & (z' + ! #%]b" f&) a t' ' D]d]b[@z \$ z' f \$ a t

System Dimensions

4-way Mini Cassette

Model: (H,Y)ICM008B21S

inch (mm)

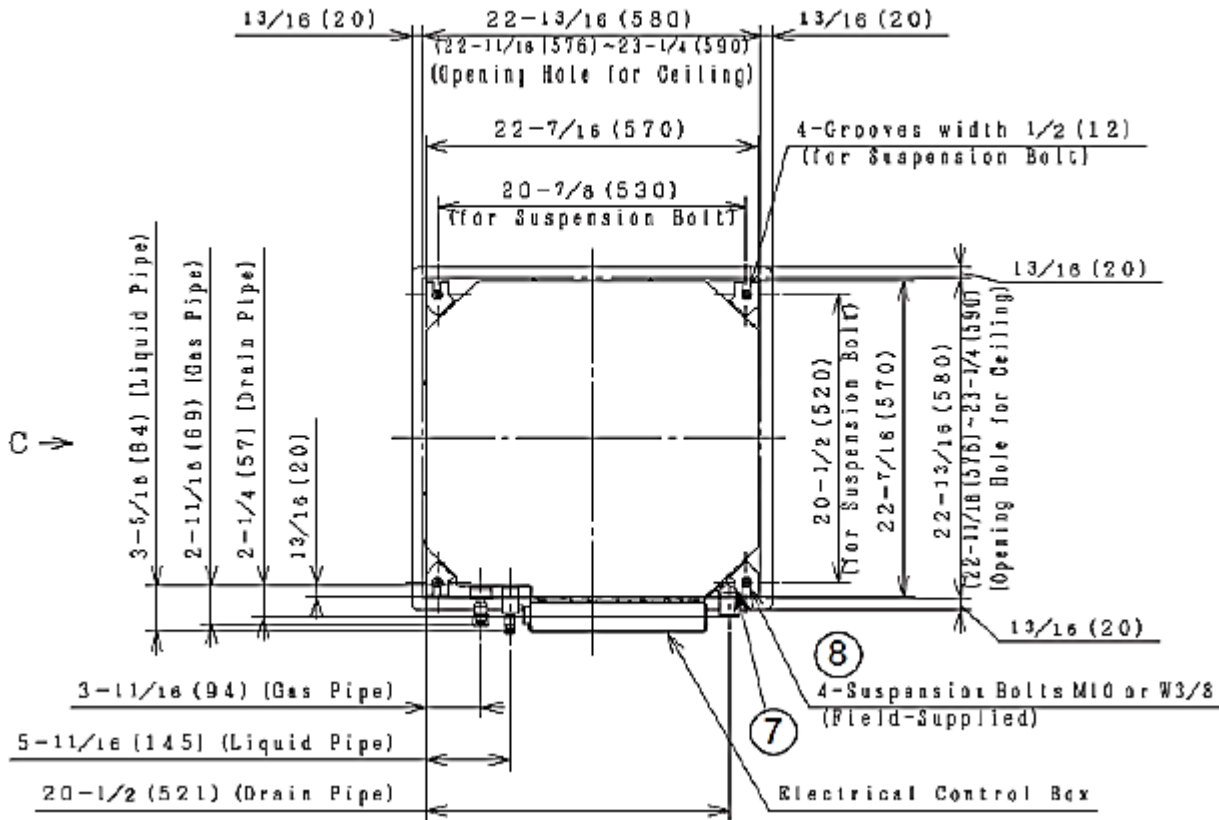

Unit: inch (mm)

Model	Dimension	a	b
(H,Y)ICM008B21S			
(H,Y)ICM012B21S		1/2 (12.7)	1/4 (6.35)
(H,Y)ICM015B21S			
(H,Y)ICM018B21S		5/8 (15.88)	3/8 (9.52)

Mark	Name	Remark
1	Air Outlet	4-Way
2	Air Inlet	
3	Refrigerant Gas Pipe Connection	with ϕ_a Flare Nut
4	Refrigerant Liquid Pipe Connection	with ϕ_b Flare Nut
5	Condensate Pipe Connection	VP1 (25)
6a	Wiring Hole for Conduit Tube	$\phi 7/8$ (22.2) Hole
6b	Wiring Hole	$\phi 1-3/16$ (30) Hole
7	Suspension Bracket	
8	Suspension Bolt	4-M10 or W3/8
9	Wired Zone Controller	without Cable
10	Shielded Communication Cable	Min. AWG18 (0.82mm ²), Field-Supplied

inch (mm)

View from C

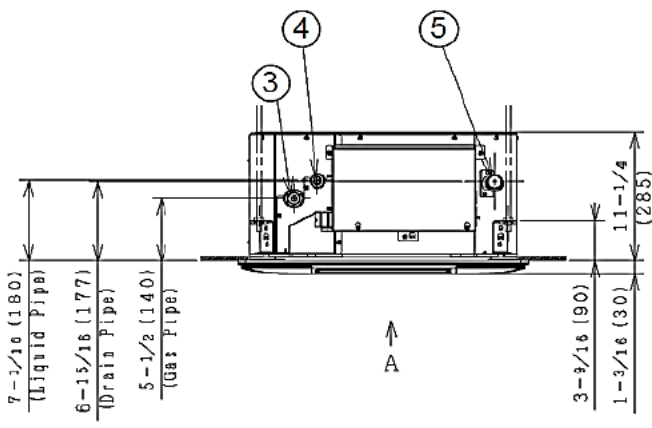
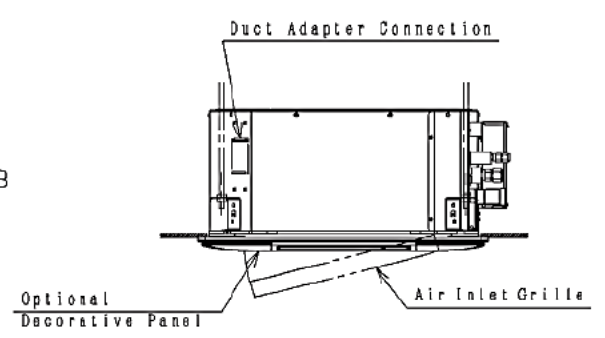

View from A

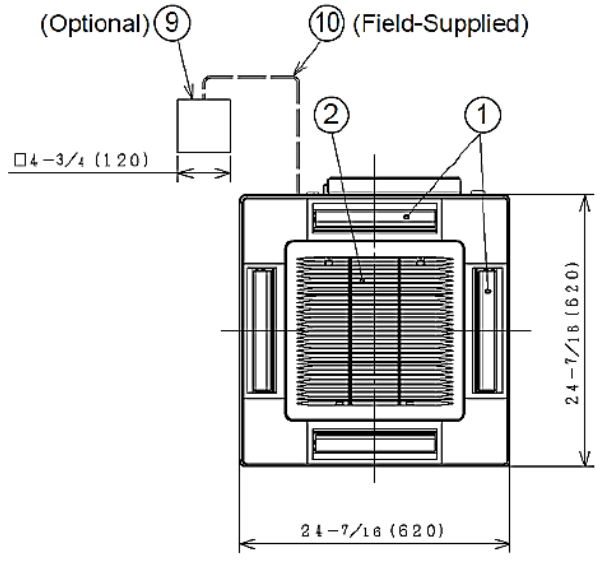

View from B

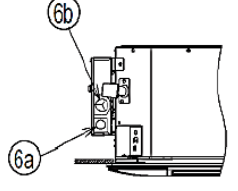

Lifting Height of Drain

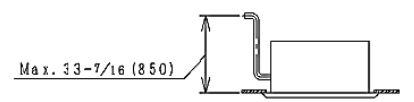

NOTES:

- 1. Distance between the wall and panel edge must be a min. 59-1/16inch (1500mm) to prevent short circuiting.

