

Submittal Data Sheet

1.3 RT (H,Y)ICM015B21S

4-way Mini Cassette

Job Name:		Location:	
Purchaser:		Order No:	
Engineer:			
Submitted To:		Approval:	Construction:
Submitted By:		Date:	
Unit Designation:		Schedule No:	Model No:



Model		(H,Y)ICM015B21S
Indoor Unit Power Supply		AC 1Phase, 208/230V, 60Hz
Nominal Cooling Capacity *1	Btu/h (kW)	15,000 (4.4)
Nominal Heating Capacity *1	Btu/h (kW)	17,000 (5.0)
Sound Pressure Level (Overall A Scale)	dB	45-39-35-31
Outer Dimensions		
Height	in. (mm)	11-1/4 (285)
Width	in. (mm)	22-7/16 (570)
Depth	in. (mm)	22-7/16 (570)
Net Weight	lbs (kg)	37 (17)
Refrigerant		R410A
Indoor Fan		
Air Flow Rate (Hi2-Hi-Me-Lo)	cfm (m ³ /min)	530-424-353-282 (15-12-10-8)
External Pressure	in.W.G (Pa)	0.0 (0)
Motor Nominal Output	W	57
Min Circuit Amps	A	1
Maximum Fuse Amps	A	15
Connections		
Refrigerant Piping		Flare-Nut Connection (with Flare Nuts)
Liquid Line	in. (mm)	1/4 (6.35)
Gas Line	in. (mm)	1/2 (12.70)
Condensate Drain		VP25
OD	in. (mm)	1-1/4 (32)
ID	in. (mm)	31/32 (25)

FEATURES

- High performance and high efficiency heat exchanger
- Efficient turbo fan for low-noise performance
- Energy-saving motion sensor that adapts to occupant activity
- Wide range of air flow volume settings

ACCESSORIES

- IR Receiver Kit, CMIRK01
- Motion Sensor Kit, SOR-NEC
- Duct Adapter, PD-75C

Adaptable Panel Model		P-AP56NAM	
Color		Neutral White	
Outer Dimensions			
Height	in. (mm)	1-3/16(30)	
Width	in. (mm)	24-13/32 (620)	
Depth	in. (mm)	24-13/32 (620)	
Net Weight	lbs (kg)	6 (3)	

NOTES:

*1. Nominal capacity is based on combinations within the VRF system under the following conditions:

Cooling Operation Conditions

Indoor Air Inlet Temperature: 80°F DB (26.7°C DB)
67°F WB (19.4°C WB)

Outdoor Air Inlet Temperature: 95°F DB (35.0°C DB)

Heating Operation Conditions

Indoor Air Inlet Temperature: 70°F DB (21.1°C DB)

Outdoor Air Inlet Temperature: 47°F DB (8.3°C DB)
43°F WB (6.1°C WB)

Piping Length: 24 ft. 7-3/16 in. (7.5m) Piping Lift: 0ft. (0m)

System Dimensions

4-way Mini Cassette

Model: (H,Y)ICM015B21S

inch (mm)

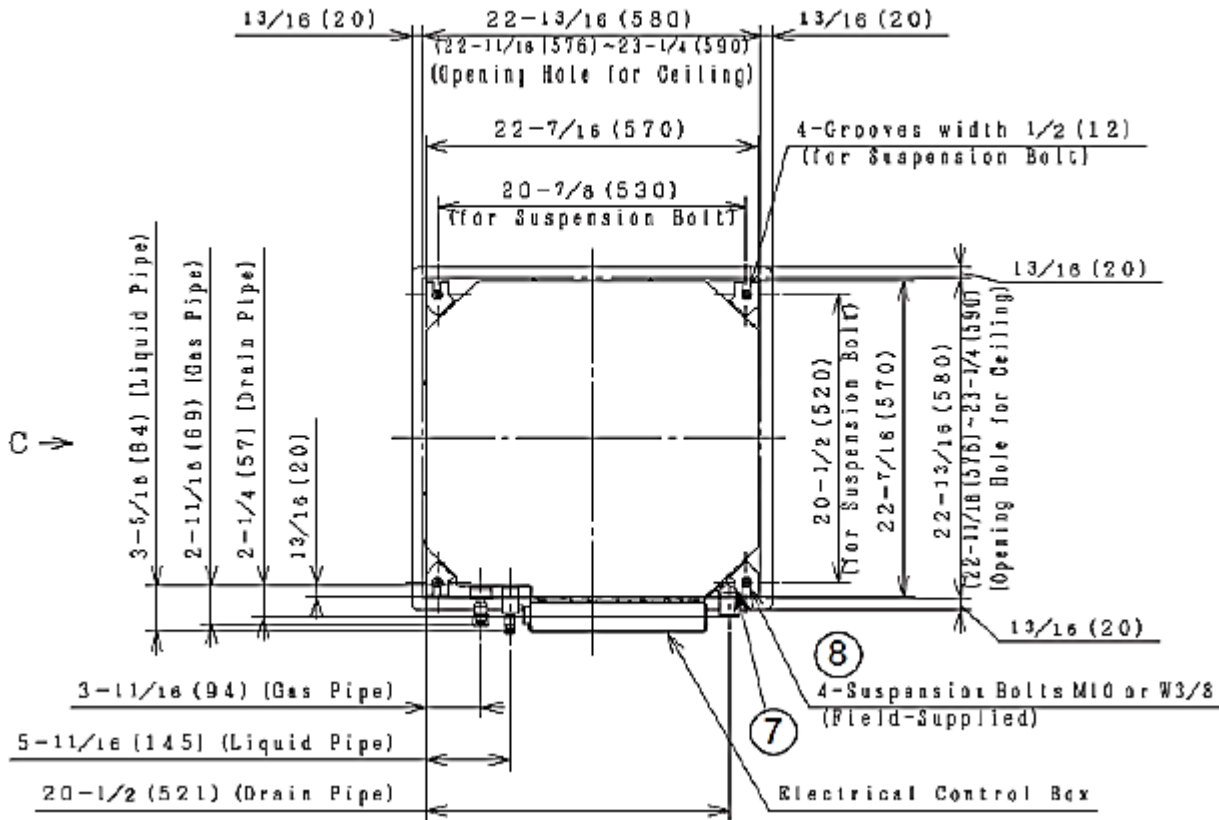

Unit: inch (mm)

Model \ Dimension	a	b
(H,Y)ICM008B21S		
(H,Y)ICM012B21S	1/2 (12.7)	1/4 (6.35)
(H,Y)ICM015B21S		
(H,Y)ICM018B21S	5/8 (15.88)	3/8 (9.52)

Mark	Name	Remark
1	Air Outlet	4-Way
2	Air Inlet	
3	Refrigerant Gas Pipe Connection	with ϕ_a Flare Nut
4	Refrigerant Liquid Pipe Connection	with ϕ_b Flare Nut
5	Condensate Pipe Connection	VP1 (25)
6a	Wiring Hole for Conduit Tube	$\phi 7/8$ (22.2) Hole
6b	Wiring Hole	$\phi 1-3/16$ (30) Hole
7	Suspension Bracket	
8	Suspension Bolt	4-M10 or W3/8
9	Wired Zone Controller	without Cable
10	Shielded Communication Cable	Min. AWG18 (0.82mm ²), Field-Supplied

inch (mm)

View from C

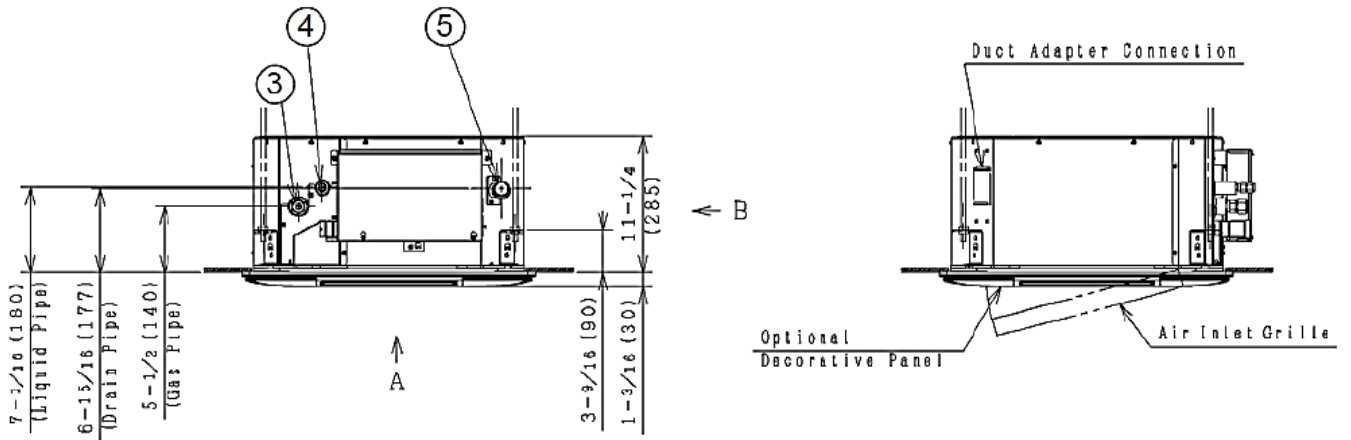

View from A

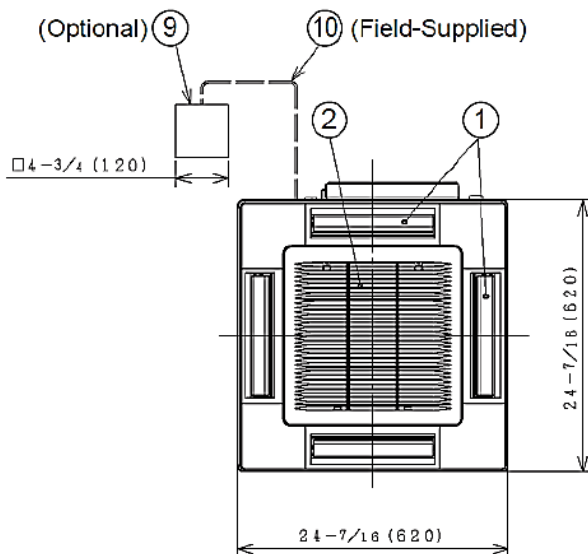

View from B

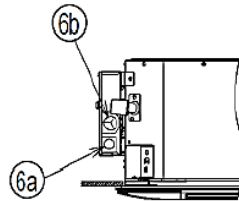

Lifting Height of Drain

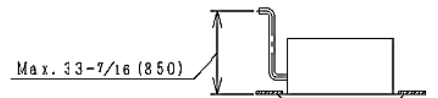

NOTES:

1. Distance between the wall and panel edge must be a min. 59-1/16inch (1500mm) to prevent short circuiting.

