

Submittal Data Sheet

(Y, H) VAHP060B21S

60,000 Btu/h Mini VRF Outdoor Unit

Job Name:		Location:	
Purchaser:		Order No:	
Engineer:			
Submitted To:		Approval:	Construction:
Submitted By:		Date:	
Unit Designation:		Schedule No:	Model No:

Model				(Y,H)VAHP060B21S	
Power Supply				208/230V/ 1PH 60Hz	
Capacity (Nominal) *1	Cooling	Capacity (Nominal)	Btu/h	(kW)	60,000 (17.6)
		Power input	kW		5.05
		Current input	A(208V/230V)		24.8 / 22.4
	Heating	Capacity (Nominal)	Btu/h	(kW)	66,000 (19.3)
		Power input	kW		4.42
		Current input	A(208V/230V)		21.7 / 19.6
Efficiency Ratings *1 (Non-Ducted / Ducted)	Cooling	Rated Capacity	Btu/h		60,000 / 55,000
		EER	Btu/Wh		15.9 / 9.60
		SEER	Btu/Wh		16.80 / 15.90
	Heating	Rated Capacity	Btu/h		64,000 / 64,000
		COP	W/W		3.90 / 3.30
		HSPF	Btu/Wh		12.10 / 10.60
Cooling Operating Range *2	Indoor	°F WB (°C WB)		59 (15) – 73 (23)	
	Outdoor	°F DB (°C DB)		23 (-5) – 118 (48)	
Heating Operating Range *2	Indoor	°F DB (°C DB)		59 (15) – 80 (27)	
	Outdoor	°F WB (°C WB)		-4 (-20) – 59 (15)	
Cabinet Color (Munsell Code)				1.0Y8.5/0.5	
Outer Dimensions	Height	in	(mm)	54-5/16 (1380)	
	Width	in	(mm)	37-3/8 (950)	
	Depth	in	(mm)	14-9/16 (370)	
Package Dimensions	Height	in	(mm)	59-9/16 (1513)	
	Width	in	(mm)	40-3/8 (1025)	
	Depth	in	(mm)	18-1/8 (460)	
Weight	Net	lbs	(kg)	249 (113)	
	Gross	lbs	(kg)	267 (121)	
Connection Ratio	Total Indoor Unit Capacity	%		60-105	
	Max. indoor units/system	—		8	
Heat Exchanger	Type	—		Multi-Pass Cross-Finned Tube	
	Material	—		Cu-Al (Anti-corrosion)	
Compressor	Type	—		HA36PHD-A1S2	
	Motor Phase / Pol	—/—		3PH / 6	
	Start Method	—		inverter	
	Operation Range	%		10 – 100	
	Refrigeration Oil Type	—		FVC68D	
Crank Case Heater		WxQty		52W(208V) x1	
Fan	Type	—		Propeller Fan	
	Quantity	Qty		2	
	Motor Output (Pole)	W(Pole)		58(10) + 58(10)	
	Air Flow Rate	cfm	(m ³ /min)	3530 (100)	
	Drive	—		Direct-drive	
Electrical	Min. Circuit Amps	A		31	
	Max. Overcurrent Protective Device	A		40	
Sound Pressure Level*3	Cooling (Night-Shift)	dB(A)		53 (46)	
	Heating	dB(A)		56	
Protection devices	Cycle	—		High pressure switch at 601psi (4.15MPa)	
	Compressor	—		Over-current protection Over-heat protection Circuit Breaker (30A)	
	Fan Motor	—		Over-current protection Over-heat protection Self-contained fuse (5A)	
	PCB (Control Circuit)	—		Fuse on PCB(5A)	
Refrigerant	Type	—		R410A	
	Charge amount	lbs	(kg)	7.9 (3.6)	
Refrigeration Oil	Charge amount	gal/Unit	(ℓ/Unit)	0.34 (1.3)	
	Defrost Method		—		Reversed Refrigerant Cycle
Main Refrigerant Piping	Gas Line	in	(mm)	5/8 (15.88)	
	Liquid Line	in	(mm)	3/8 (9.52)	

FEATURES

- Cooling up to 118°F and heating down To -4°F.
- One outdoor unit for up to 8 indoor units
- Ideal choice for building with zero lot Lines or zoning restrictions
- Flexible – Numerous systems configurations multiple-sized outdoor units and multiple options of indoor unit types and capacities
- Adaptable – Up to 984 ft. total pipe length
- Versatile – Up to 164ft. vertical distance between outdoor unit and indoor units
- Quiet operations – as low as 48 dB(A) sound level for outdoor units and 28 dB(A) for indoor units

NOTES:

*1. Rating conditions are based on the AHRI testing standard. See www.ahrinet.org for more information:

Cooling

Indoor Air Inlet Temperature: 80°F (26.7°C)DB
67°F (19.4°C)WB

Outdoor Air Inlet Temperature: 95°F (35.0°C)DB

Heating

Indoor Air Inlet Temperature: 70°F (21.1°C)DB

Outdoor Air Inlet Temperature: 47°F (8.3°C)DB

43°F (6.1°C)WB

Piping Length: 24ft. 7-3/16in. (7.5m)

Piping Lift: 0ft. (0m)

*2 For more details, please refer to Engineering manual "Operation range" section.

*3 Measurement Point: 3.3ft. (1m) from the air outlet side, 4.9ft. (1.5m) from floor level.

The operation sound is measured in an anechoic chamber. However, the actual operation sound may appear louder or with an echo because of surrounding environmental noise. Be sure to check environmental conditions before installation.

The sound of the air inlet side is 3dB higher than that of the air outlet side.

System Dimensions

60,000 BTU/H Mini VRF Outdoor Unit

Model – (Y,H) VAHP060B21S

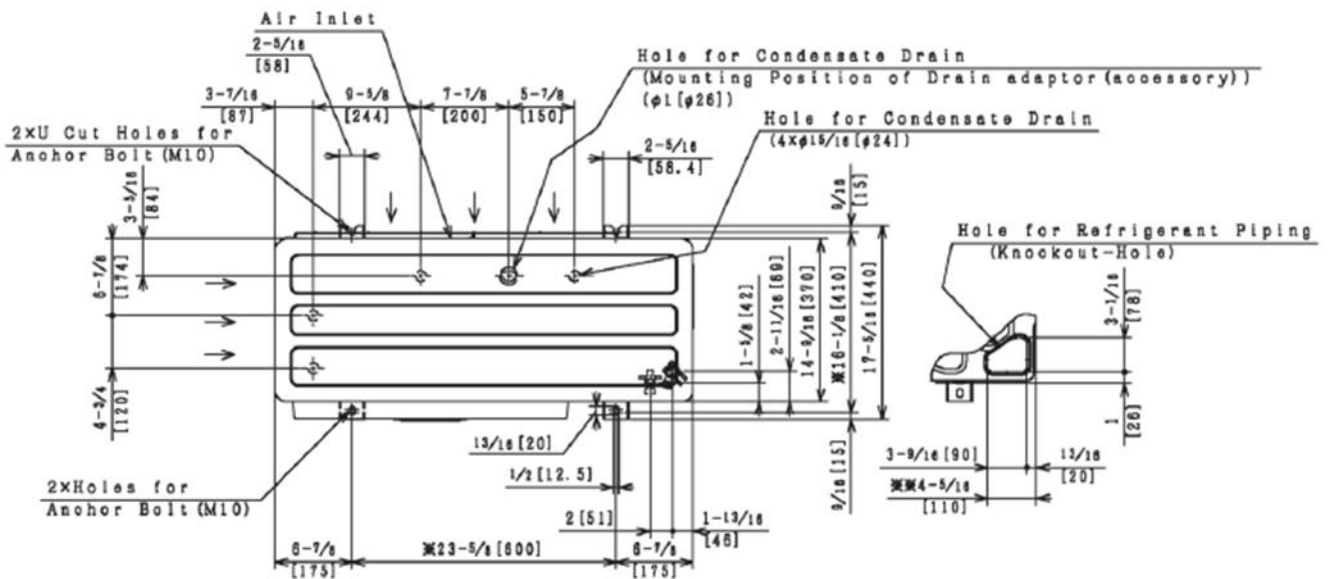

• A side view

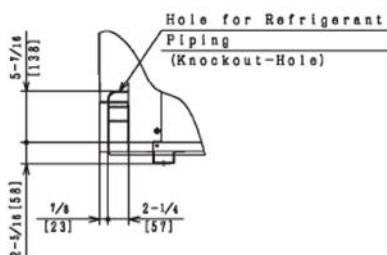

Drain Water

Drain water is caused during heating operation or defrost operation.

- ① Choose a place where well drainage is available. Or provide a groove for drain.
- ② Do not provide an upward slope from the unit to avoid reverse flow of the drain.
- ③ When dropping drain water is not permissible, provide a second drainpan under the outdoor unit, to collect drain water securely.

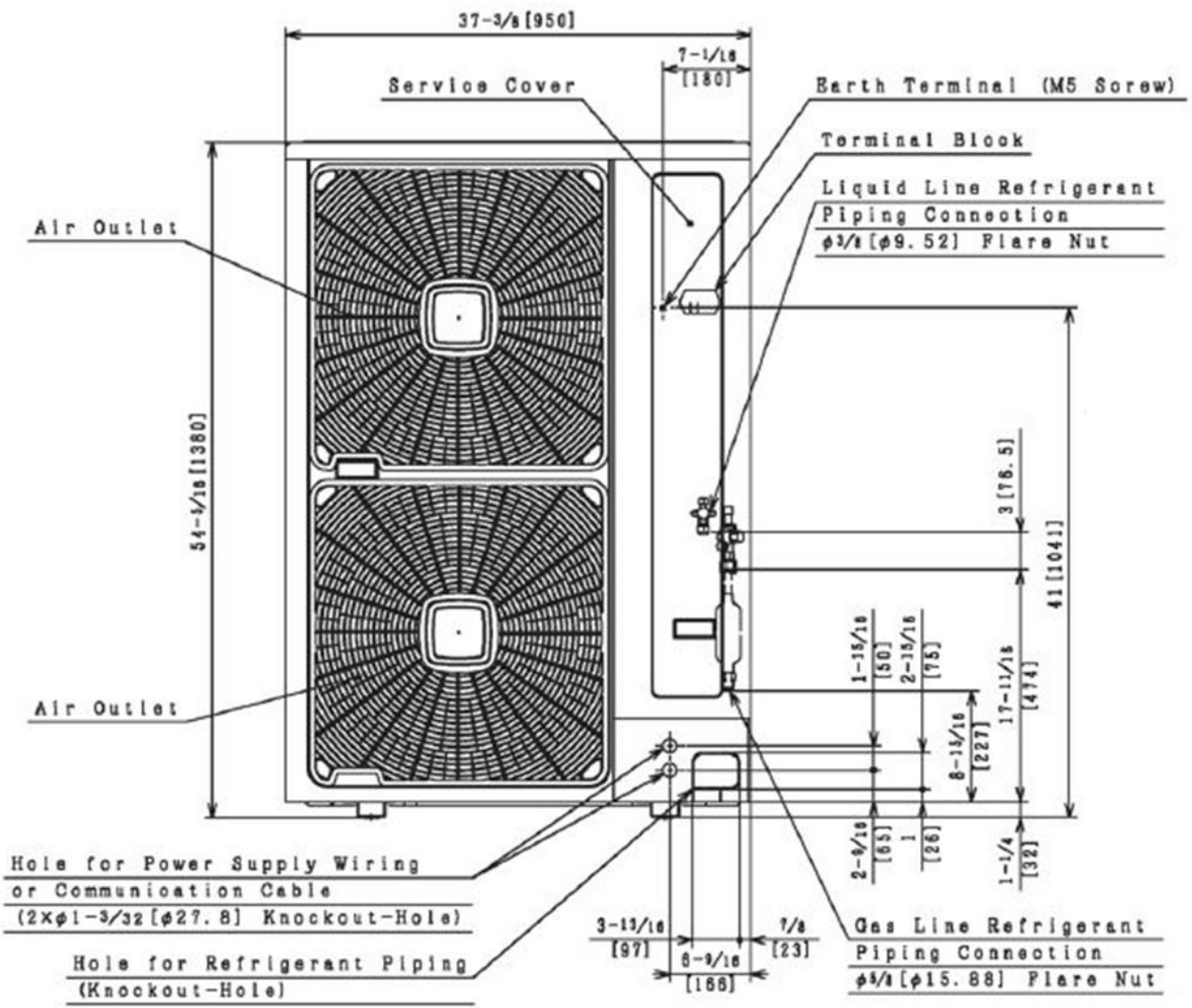

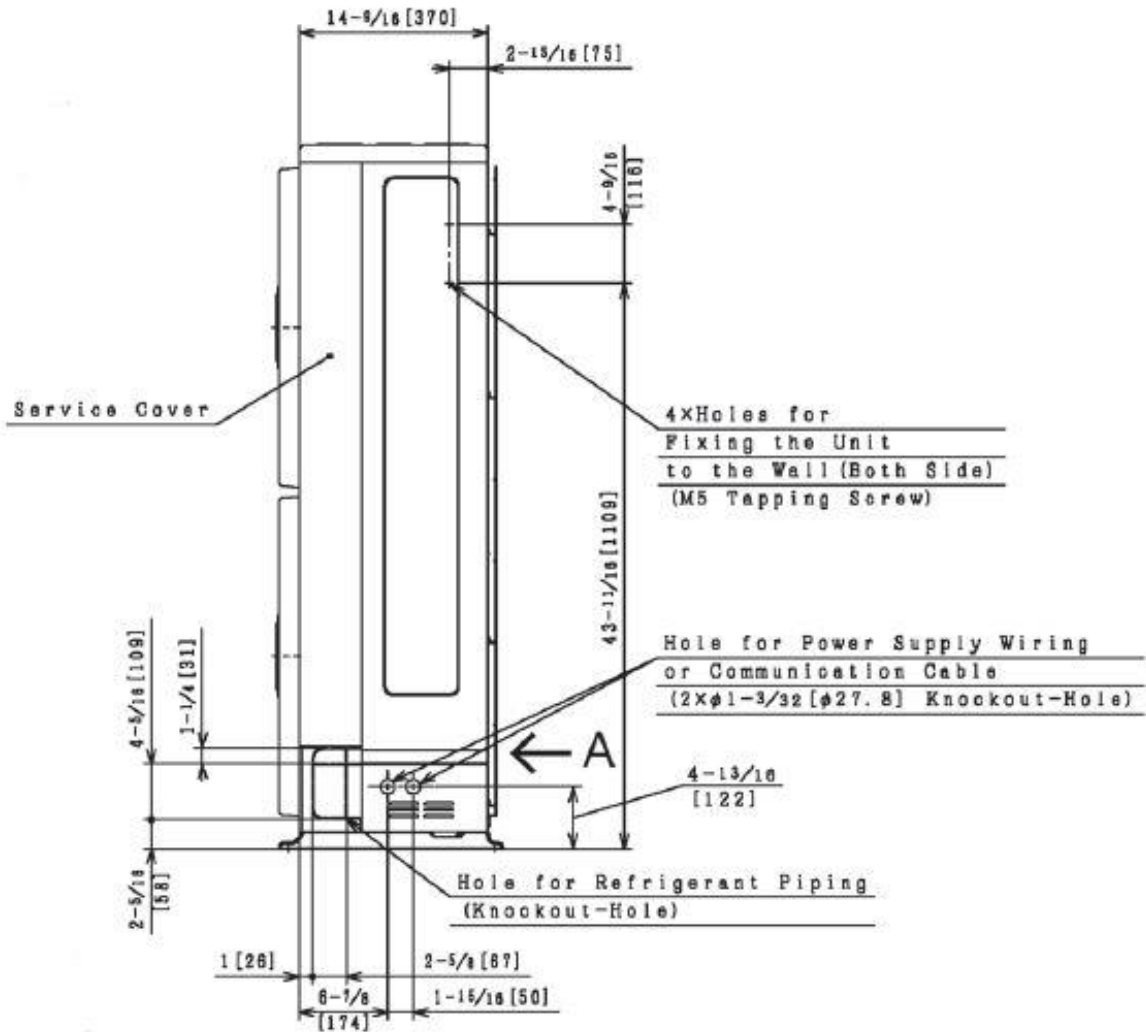

NOTES:

1. There are stop valves in the cabinet.
2. When connecting field refrigerant piping from the bottom side of the unit, provide the space (marked with ※) for understructures such as foundation to avoid interference.
3. The dimension marked with ※ indicates the mounting pitch dimension for anchor bolts.

