

Installation Manual for Snow Protection Hood (for Outdoor Unit)

Model: ASG-TP20LS2

This snow protection hood prevents snow from entering the outdoor unit and prevents a strong wind from blowing against the heat exchanger. Be sure to read this manual carefully for correct performance before installation work.

IMPORTANT NOTICE:

- Johnson Controls pursues a policy of continuous improvement in design and performance of products. We reserve the right to vary specifications without notice.
- No part of this manual may be reproduced without Johnson Controls' written permission.
- Keep this manual for future reference.
- Johnson Controls cannot anticipate every possible circumstance that might involve a potential hazard.
- This kit is designed for a combination of Johnson Control air conditioners. Do not use this kit by itself or in combination with other companies' air conditioners.
- To hold the snow protection hood properly to the outdoor unit against the strong wind or earthquake, stay or safety wire rope shall be used for reinforced installation. Use the field-supplied safety wire rope to prevent outdoor unit from overturning.
- Perform a test run after installation to check for abnormalities.
- Signal words are used to identify levels of hazard seriousness. Definitions for identifying hazard levels are provided below with their respective signal words.

⚠ WARNING

: Indicates a hazardous situation that, if not avoided, could result in death or serious injury.

⚠ CAUTION

: Indicates a hazardous situation that, if not avoided, could result in minor or moderate injury.

1. Applicable Unit

Name	Hood for Left Side Air Inlet
Model	ASG-TP20LS2
Required Qty.	x 1
Applicable Outdoor Unit	Top Flow Type 72,000, 96,000, and 120,000 Btu/h

NOTE:

The applicable outdoor unit may be different depending on the product series. Be sure to confirm with the product catalogue before installation.

2. Installation Work

- (1) After the snow protection hood is installed, electromagnetic noise at the air outlet side may slightly increase. Therefore, it is necessary to carefully consider the air discharge direction when installed.
- (2) Be sure to tighten the snow protection hood securely to the top panel and side panel of the outdoor unit with the supplied screws (accessories). Not doing so may cause vibration or abnormal noise.
- (3) There must be no obstacles in the air discharge direction of the snow protection hood. If there are, it may cause a short circuit or an insufficient airflow rate.
- (4) Do not install other outdoor units in the direction of the air outlet. If the air blown out of the snow protection hood is sucked into the other outdoor unit, it may cause a malfunction of the unit.
- (5) The wind loads which the outdoor unit receives changes by attaching the snow protection hood. The required installation strength will also change in strong wind. Therefore, recheck the strength of the anchor bolts of the outdoor unit.
- (6) If the snow protection hood is installed, cooling/heating performance may be slightly lowered depending on the usage conditions.

⚠ WARNING

To hold the snow protection hood properly to the outdoor unit against a strong wind or an earthquake, safety wire rope should be used for reinforced installation. Use the field-supplied safety wire rope to prevent the outdoor unit from overturning.

⚠ CAUTION

- Install the snow protection hood so as to avoid facing directly toward seasonal or strong winds.
- Apply touch-up coating or caulking (field-supplied) at the screw holes of the outdoor unit in order to prevent rusting.
- Even though the hood is stainless, salt or iron may cause rust. Be aware of this during installation or maintenance.
- The snow protection hood is heavy-weight. More than two people are required for installation. Be sure to wear protective equipment (such as gloves).
- The screws and the snow protection hood must be protected from scratches or scrapes. If they aren't, it may be the cause of rusting. Handle with care when the snow protection hood is installed and assembled.

< Caulking Procedures (Example) >

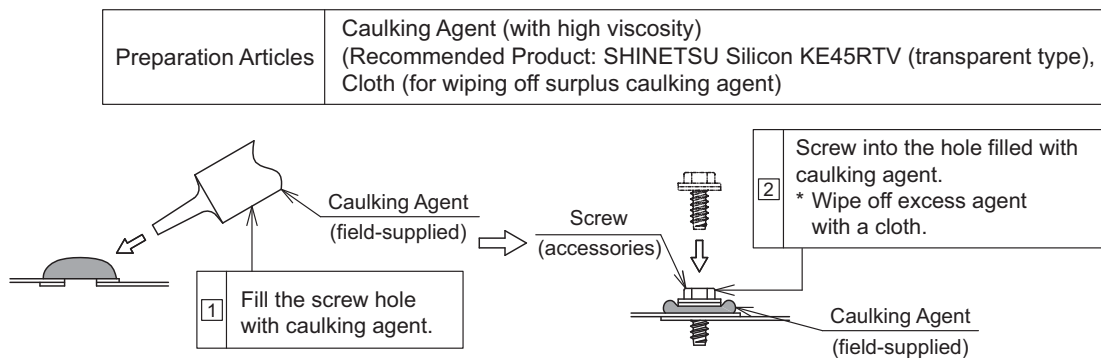

3. Selection of Installation Location

- (1) Install the outdoor unit at a suitable height with consideration for snow accumulation. Increase the base height or additionally provide the frame under the unit (higher than snow accumulation), and fix the outdoor unit securely with anchor bolts.
- (2) Secure enough service space with consideration for snow accumulation height and snow removal operation.
- (3) There must be no obstacles in the air discharge direction.
- (4) Be sure to apply touch-up coating or caulking agent at the screw attaching portions for rustproofing.
- (5) In an instance of multiple outdoor units being installed, provide service space as shown below.



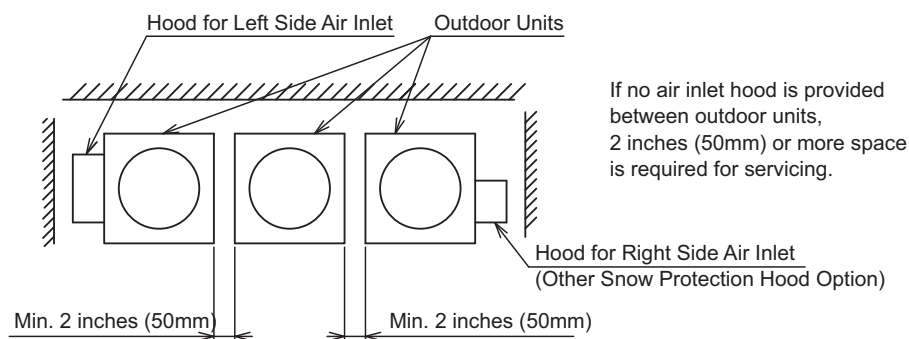



< Service Space for Multiple Outdoor Units Installation >

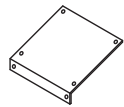

4. Before Installation

Check that all the following accessories are packed with the unit before installation.

Unit: inch (mm)

No.	Accessory		Qty.	Remarks
			ASG-TP20LS2	
①	Right Side Plate		1	
②	Left Side Plate		1	
③	Faceplate (Top Side)		1	
④	Faceplate (Back Side)		1	
⑤	Screw (for Installation)	 M5 x 15/32L (12L) (tapping screw type B)	8 (2)	For installation: accepting burring TP hole (2): Spare
⑥	Screw (for Assembling)	 M5 x 9/16L (14L) (tapping screw type C)	17 (2)	For installation: accepting weld nut (2): Spare

5. Installation Procedures

- (1) Tighten the faceplate (back side) (④) with the right side plate (①) and left side plate (②) together (8 places) by using screws for assembling (⑥).

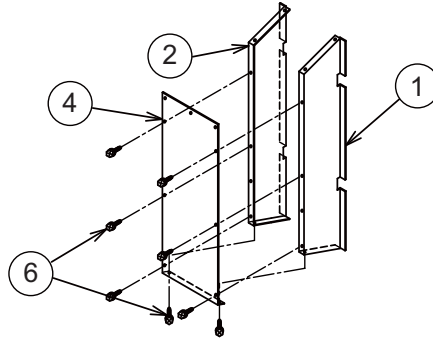

- (2) Tighten the faceplate (top side) (③) (7 places) by using screws for assembling (⑥).

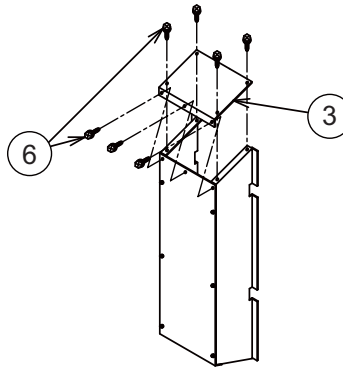

- (3) Tighten loosely two screws (for installation) at the top of the snow protection hood (⑤) to the outdoor unit, and set the snow protection hood (for left side air inlet) to the outdoor unit. Tighten the other four screws (⑤) except for the top two screws, and finally tighten the top two screws securely.

NOTE:

The fitting slots for the hood are adjustable in its fixing position within $\pm 1/8$ inch (± 3 mm). For hood installation, there must be no gap between the outdoor unit top plate and the hood upper part. If there is a gap, ice may form inside the hood.

(Screws for Installation at the Top of the Snow Protection Hood)

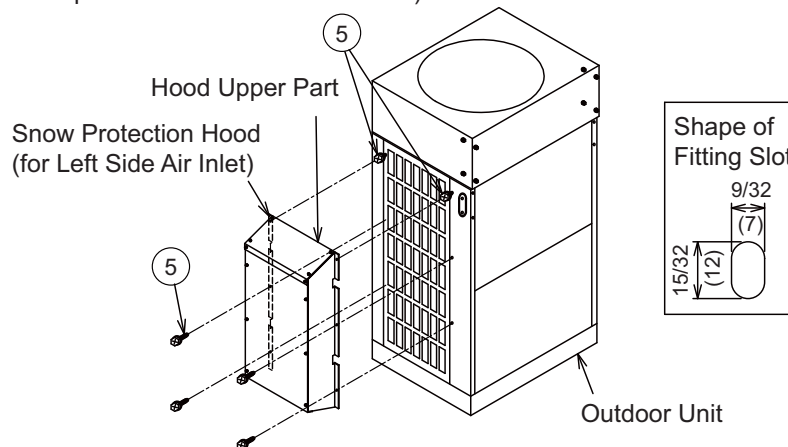

6. Installation Appearance

Unit: inch (mm)

Dimension	a
Applicable Outdoor Unit	
Top Flow Type 72,000 Btu/h	37-5/16 (948)
Top Flow Type 96,000 and 120,000 Btu/h	47-5/8 (1,210)

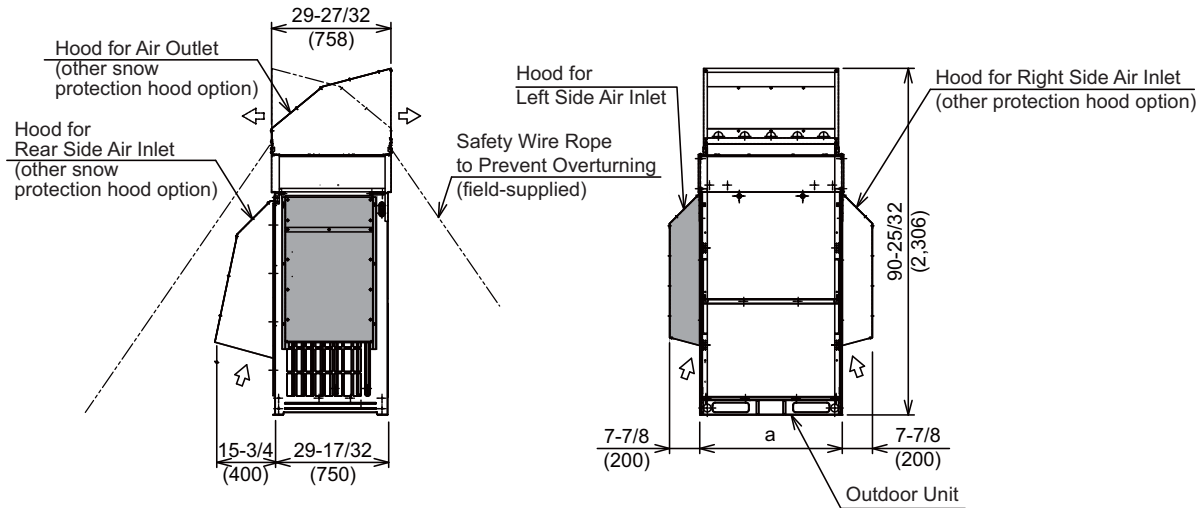

Available Combinations

Applicable Outdoor Unit	Model	
	Top Flow Type 72,000 Btu/h	Top Flow Type 96,000 and 120,000 Btu/h
Hood for Air Outlet	ASG-TP20FAS1	ASG-TP20FBS1
Hood for Rear Side Air Inlet	ASG-TP20BAS1	ASG-TP20BBS1
Hood for Left Side Air Inlet	ASG-TP20LS2	
Hood for Right Side Air Inlet	ASG-TP20RS2	

NOTE:

This installation manual applies only to the combination indicated with .
For other snow protection hood options, refer to each installation manual.

7. Maintenance and Servicing

Even if during the warranty period, the snow protection hood becomes rusted under conditions that are caused by alkaline or corrosive moisture, recommendations are to provide salt damage resistance products to prevent such damage.

In order to prolong product life, perform periodical maintenance to prevent significant aging due to deterioration. Carry out the following periodical inspection and maintenance works in conjunction with air conditioners' inspection.

(1) Red Rust Generation and Coating Film Check

If red rust is generated, or coating film is peeled/cracked, scour the rust off or apply touch-up coating. When recoating such parts, be sure to grind the coating using sandpaper (#180 to 230) before re-applying coating agent. Wear protective equipment such as vinyl gloves when handling the coating agent to prevent contact with skin.

(2) Retightening Screws for Installation and Assembly

Check for loose screws and retighten when inspection and maintenance is performed. In order to prevent screw breakage, be sure to tighten with the following torques:

* M5 Tapping Screw Type C for Assembling ⑥: 2.6 ± 0.7 [lbf-ft] (3.5 ± 1.0 [N•m])

* M5 Tapping Screw Type B for Installation ⑤: 1.8 ± 0.7 [lbf-ft] (2.5 ± 1.0 [N•m])