

Installation Manual for Duct Adaptor (for 4-Way Cassette Type)

| | |
|-------|--------|
| Model | PD-75A |
|-------|--------|

NOTE:

The applicable indoor unit may be different depending on the product series.
Refer to the product catalog for applicable indoor unit models.

IMPORTANT NOTICE:

- Johnson Controls pursues a policy of continuous improvement in design and performance of products. We reserve the right to vary specifications without notice.
- No part of this manual may be reproduced without Johnson Controls' written permission.
- Keep this manual for future reference.
- Johnson Controls cannot anticipate every possible circumstance that might involve a potential hazard.
- This kit is designed for a combination of Johnson Control air conditioners. Do not use this kit by itself or in combination with other companies' air conditioners.
- Perform a test run after installation to check for abnormalities.
- Signal words are used to identify levels of hazard seriousness. Definitions for identifying hazard levels are provided below with their respective signal words.

▲ DANGER

: Indicates a hazardous situation that, if not avoided, will result in death or serious injury.

▲ WARNING

: Indicates a hazardous situation that, if not avoided, could result in death or serious injury.

▲ CAUTION

: Indicates a hazardous situation that, if not avoided, could result in minor or moderate injury.

NOTICE

: Indicates information considered important, but not hazard-related (e.g. messages relating to property damage).

NOTE

: Indicates an useful information for operation and/or maintenance.

- It is assumed that this kit will be installed and serviced by English speaking people. If this is not the case, the customer should add safety, caution and operating signs in the native language.
- If you have any questions, contact your distributor or contractor.
- This manual gives a common description and information for this kit, as well as for other model you may operate.
- This manual should be considered a permanent part of the air conditioning equipment and should remain with the air conditioning equipment. Forward this information to the building owner and request that they maintain all the equipment manuals.

This duct adaptor is used as the connection flange to install the fresh air intake duct.

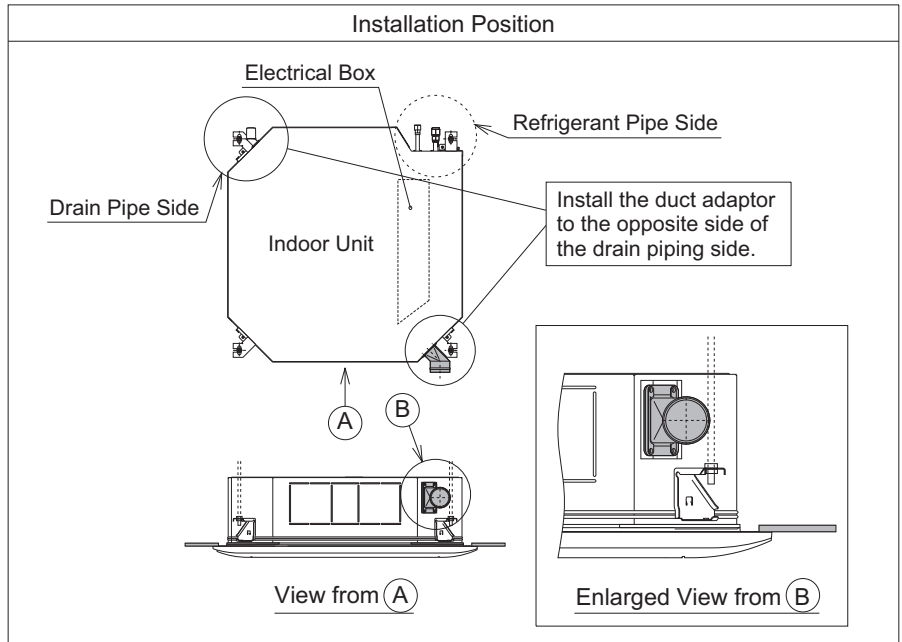

1. Factory-Supplied Accessories

Unit: inch (mm)

| Accessory | Qty. | Purpose |
|--------------|------|--|
| Duct Adaptor | 1 | - |
| Insulation A | 2 | For Covering Gap between Insulation and Side Plate |
| Insulation B | 2 | |
| Insulation | 1 | For Prevention of Condensation |
| Screw | 4 | For Installation |

(M4 x 13/32 (10) Truss)

2. Installation

(1) Attach the duct adaptor to the indoor unit according to the following procedures.

< Procedures >

- 1 Cut off the knockouts from the side plate using shears.
- 2 Cut off the insulation (Polystyrene) along the notch using a knife or something similar.
- 3 Remove burr after the cutting work. (Be careful not to let swarf enter inside of the indoor unit.)
- 4 Remove swarf after cutting off the insulation (Polystyrene).

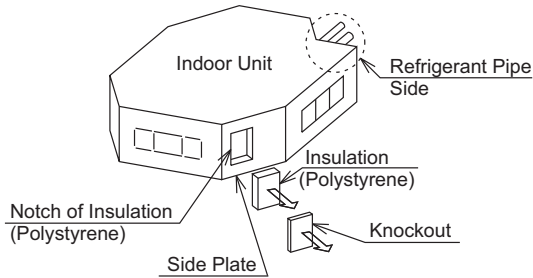

CAUTION

- Do not insert the knife more than 1-3/16inch (30mm) into the insulation (Polystyrene) when cutting off the insulation. Do not cut off the (A) part in Fig. 2.
- Do not use any tools which produce a lot of swarf such as a saw for the opening work. The drain pipe can become clogged and cause water leakage.

(2) Place the insulation A and B to cover the entire gap between the side plate and the insulation (Polystyrene). Attach the insulation A to the left and right of the opening and the insulation B to the top and bottom of the opening. Be careful not to cover the screw hole at the indoor unit side during placement.

CAUTION

Perform this work correctly. Otherwise, condensation may occur when cold air enters any gap left between the side plate and the insulation (Polystyrene).

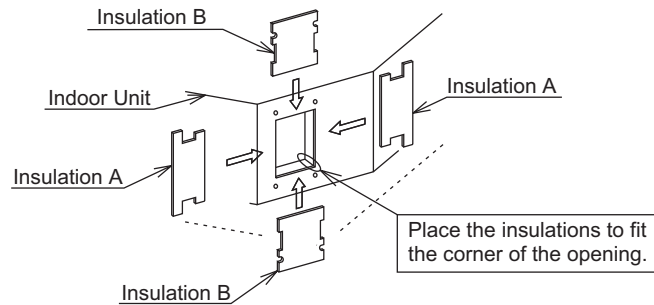
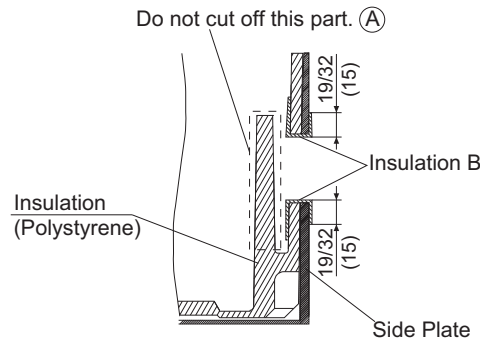
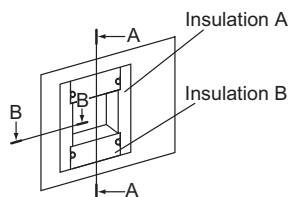
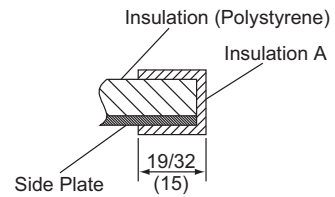

Fig. 1 Position of Insulation Placement



A - A

Unit: inch (mm)



B - B

CAUTION

Place the insulations to cover the entire gap between the side plate and the insulation (Polystyrene).

Fig. 2 Cross Section of Insulation Placement

(3) Secure the duct adaptor using four screws.

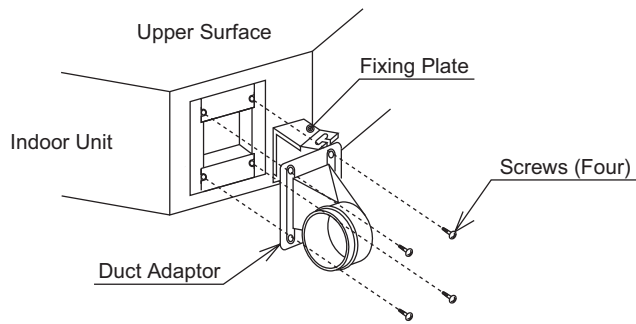

(4) Wrap whole parts from the band for the flexible duct to the resin part of the duct adaptor with the insulation.

Wrap the flexible duct with the insulation so it touches the indoor unit.

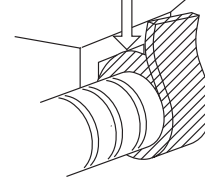

CAUTION

Tighten the band to secure the flexible duct. (Field-Supplied, Tightening Torque: 108 ft·lbs. (147 N·cm))