

Installation Manual for Snow Protection Hood (for Left Side)

Model: ASG-SP11LAS3

This Snow Protection Hood prevents snow from entering the outdoor unit and prevents strong winds from blowing against the heat exchanger. Be sure to read this manual carefully for correct performance before installation work.

IMPORTANT NOTICE:

- Johnson Controls pursues a policy of continuous improvement in design and performance of products. We reserve the right to vary specifications without notice.
- No part of this manual may be reproduced without Johnson Controls' written permission.
- Keep this manual for future reference.
- Johnson Controls cannot anticipate every possible circumstance that might involve a potential hazard.
- This kit is designed for a combination of Johnson Control air conditioners. Do not use this kit by itself or in combination with other companies' air conditioners.
- To hold the Snow Protection Hood properly to the outdoor unit against the strong wind or earthquake, a stay or safety wire rope should be used for reinforced installation. Use the field-supplied safety wire rope to prevent the outdoor unit from overturning.
- Perform a test run after installation to check for abnormalities.
- Signal words are used to identify levels of hazard seriousness. Definitions for identifying hazard levels are provided below with their respective signal words.



: Indicates a hazardous situation that, if not avoided, could result in death or serious injury.



: Indicates a hazardous situation that, if not avoided, could result in minor or moderate injury.

1. Applicable Unit

Name	Hood for Left Side Air Inlet
Model	ASG-SP11LAS3
Applicable Outdoor Unit	Side Flow Type 36,000 to 60,000 Btu/h

NOTE:

The applicable outdoor unit may be different depending on the product series. Be sure to confirm with the product catalogue before installation.

2. Installation Work

- (1) After the Snow Protection Hood is installed, operation noise at the air outlet side may slightly increase. Therefore, it is necessary to carefully consider the air discharge direction when installing.
- (2) Be sure to tighten the Snow Protection Hood securely to the side panel of the outdoor unit with the supplied screws (accessories). Not doing so may cause vibration or abnormal noise.
- (3) There must be no obstacles in the air discharge direction of the Snow Protection Hood. If there are, it may cause a short circuit or an insufficient airflow rate.
- (4) Do not install other outdoor units in the direction of the air outlet. If the air blown out of the Snow Protection Hood is sucked into another outdoor unit, it may cause a malfunction of the unit.
- (5) The wind loads which the outdoor unit receives changes by attaching the Snow Protection Hood. The required installation strength will also change in strong wind. Therefore, recheck the strength of the anchor bolts of the outdoor unit.
- (6) If the Snow Protection Hood is installed, cooling/heating performance may be slightly lowered depending on the usage conditions.
- (7) It is not possible to use the Snow Protection Hood with the Protection Net (optional).

⚠ WARNING

To hold the Snow Protection Hood properly to the outdoor unit against a strong wind or an earthquake, safety wire rope should be used for reinforced installation. Use field-supplied safety wire rope to prevent the outdoor unit from overturning.

⚠ CAUTION

- Install the Snow Protection Hood so as to avoid facing directly toward seasonal or strong winds.
- Apply touch-up coating or caulking (field-supplied) at the screw holes of the outdoor unit in order to prevent rusting.
- Even though the hood is stainless, salt or iron may cause rust. Be aware of this during installation or maintenance.
- The Snow Protection Hood is heavy-weight. More than two people are required for installation. Be sure to wear protective equipment (such as gloves).
- The screws and the Snow Protection Hood must be protected from scratches or scrapes. If they aren't, it may be the cause of rusting. Handle with care when the Snow Protection Hood is installed and assembled.

< Caulking Procedures (Example) >

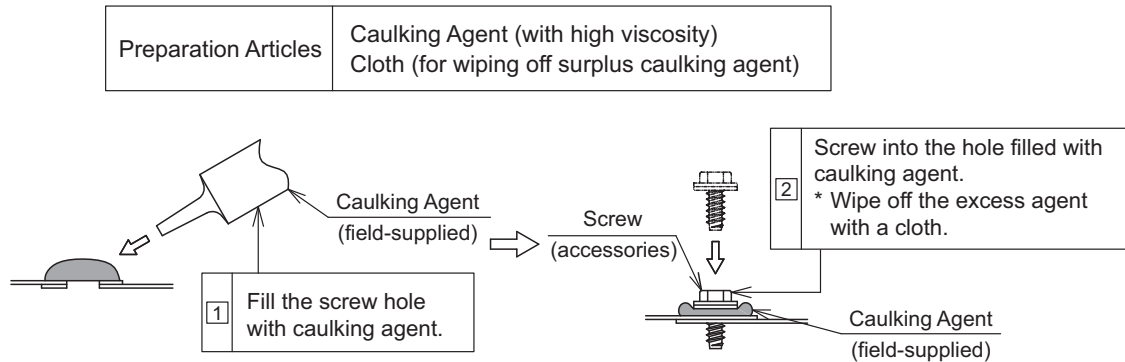







3. Selection of Installation Location

- (1) Install the outdoor unit at a suitable height with consideration for snow accumulation. Increase the base height or additionally provide a frame under the unit (higher than snow accumulation), and fix the outdoor unit securely with anchor bolts.
- (2) Secure enough service space with consideration for snow accumulation height and snow removal operation.
- (3) There must be no obstacles in the air discharge direction.
- (4) Be sure to apply touch-up coating or caulking agent at the screw attaching locations for rustproofing.

4. Before Installation

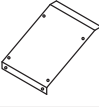
Check that all the following accessories are packed with the unit before installation.

Unit: inch (mm)

No.	Accessory		Qty.	Remarks
			ASG-SP11LAS3	
①	Right Side Plate		1	
②	Left Side Plate		1	
③	Faceplate (Top)		1	
④	Faceplate (Front)		1	
⑤	Screw	 M5 x 15/32L (12L)	10 (2)	For installation and assembling (2): Spare
⑥	Screw	 M5 x 9/16L (14L)	14 (2)	For assembling (Stainless Steel) (2): Spare

5. Installation Procedures

- (1) Assemble the faceplate (front) (④) with the right side plate (①) and left side plate (②), and tighten by using six screws for assembling (⑥).

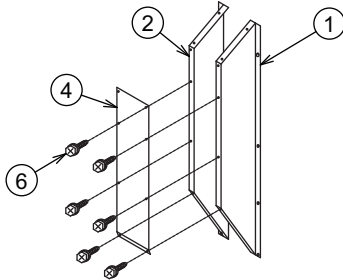

- (2) Then, secure the faceplate (top) (③) on the assembled faceplate (front) (④), left side plate (①) and right side plate (②) with eight securing screws (for assembling) (⑥).

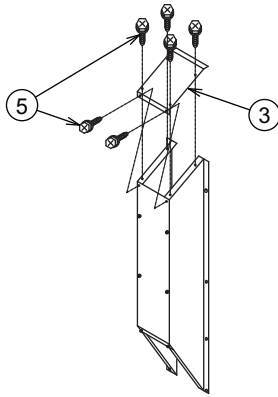

- (3) Tighten loosely the top two screws (for installation) (⑤) of the Snow Protection Hood to the outdoor unit, at this time, make sure to maintain a gap approx. 1/8 inch (3mm) for hooking the Snow Protection Hood (for left side air inlet). Then set the Snow Protection Hood (for left side air inlet) on the outdoor unit. Tighten the other six screws (⑤) except for the top two screws, and finally tighten the top two screws securely.

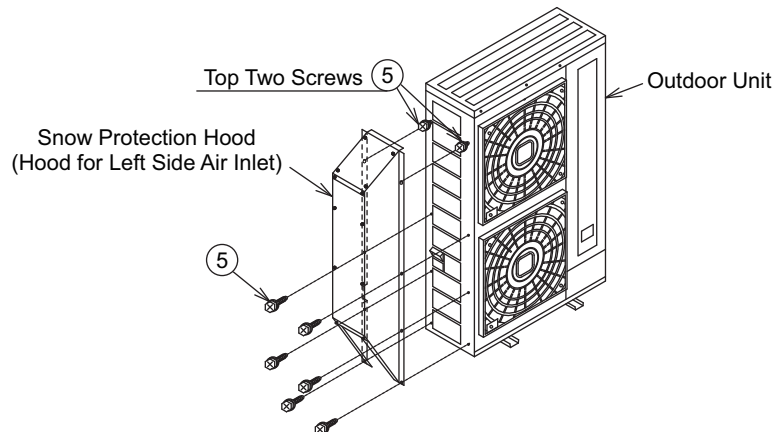

6. Installation Appearance

Unit: inch (mm)

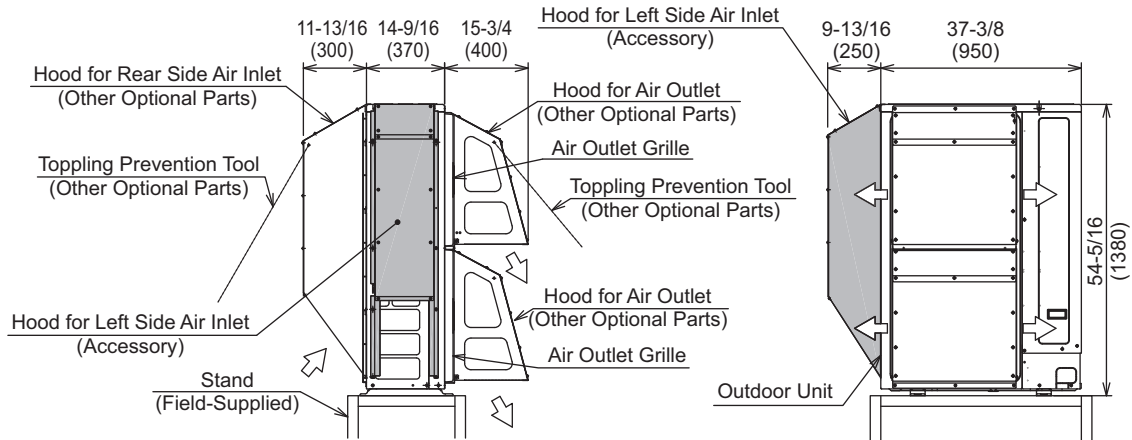

Available Combinations

Applicable Outdoor Unit	Model	Qty.
Hood for Rear Side Air Inlet	ASG-SP11BAS2	1
Hood for Left Side Air Inlet	ASG-SP11LAS3	1
Hood for Air Outlet	ASG-SP11FCS2	1

NOTE:

This installation manual applies only to the combination indicated in the shaded area above. For other Snow Protection Hood options, refer to each installation manual.

7. Maintenance and Servicing

Even if during the warranty period, the Snow Protection Hood becomes rusted under conditions that are caused by alkaline or corrosive moisture, recommendations are to provide salt damage resistance products to prevent such damage.

In order to prolong product life, perform periodic maintenance to prevent significant aging due to deterioration. Carry out the following periodic inspection and maintenance in conjunction with the air conditioner's inspection.

(1) Red Rust Generation and Coating Film Check

If red rust is generated, or coating film is peeled/cracked, scour the rust off or apply touch-up coating. When recoating such parts, be sure to grind the coating using sandpaper (#180 to 230) before re-applying coating agent. Wear protective equipment such as vinyl gloves when handling the coating agent to prevent contact with skin.

(2) Retightening Screws for Installation and Assembly

Check for loose screws and retighten when inspection and maintenance is performed. In order to prevent screw breakage, be sure to tighten with the following torques:

* M5 Tapping Screw Type C for Assembling ⑥: 2.6 ± 0.7 [lbf-ft] (3.5 ± 1.0 [N•m])

* M5 Tapping Screw Type B for Installation ⑤: 1.8 ± 0.7 [lbf-ft] (2.5 ± 1.0 [N•m])